

## CHAPTER 8

# ROOF-CEILING CONSTRUCTION

### SECTION R801 GENERAL

**R801.1 Application.** The provisions of this chapter shall control the design and construction of the roof-ceiling system for all buildings.

**R801.2 Requirements.** Roof and ceiling construction shall be capable of accommodating all loads imposed according to Section R301 and of transmitting the resulting loads to the supporting structural elements.

**R801.3 Roof drainage.** In areas where expansive or collapsible soils are known to exist, all *dwelling*s shall have a controlled method of water disposal from roofs that will collect and discharge roof drainage to the ground surface at least 5 feet (1524 mm) from foundation walls or to an *approved* drainage system.

**R801.4 Drainage control.** Where required by the building official, all *dwelling*s shall have a controlled method of water disposal from roofs that will collect and discharge all roof drainage in accordance with the *Plumbing Code*.

### SECTION R802 WOOD ROOF FRAMING

**R802.1 Identification.** Load-bearing dimension lumber for rafters, trusses and ceiling joists shall be identified by a grade mark of a lumber grading or inspection agency that has been approved by an accreditation body that complies with DOC PS 20. In lieu of a grade mark, a certificate of inspection issued by a lumber grading or inspection agency meeting the requirements of this section shall be accepted.

**R802.1.1 Blocking.** Blocking shall be a minimum of utility *grade* lumber.

**R802.1.2 End-jointed lumber.** *Approved* end-jointed lumber identified by a grade mark conforming to Section R802.1 may be used interchangeably with solid-sawn members of the same species and grade.

**R802.1.3 Fire-retardant-treated wood.** Fire-retardant-treated wood (FRTW) is any wood product which, when impregnated with chemicals by a pressure process or other means during manufacture, shall have, when tested in accordance with ASTM E 84, a listed flame spread index of 25 or less and shows no evidence of significant progressive combustion when the test is continued for an additional 20-minute period. In addition, the flame front shall not progress more than 10.5 feet (3200 mm) beyond the center line of the burners at any time during the test.

**R802.1.3.1 Pressure process.** For wood products impregnated with chemicals by a pressure process, the process shall be performed in closed vessels under pressures not less than 50 pounds per square inch gauge (psig) (344.7 kPa).

**R802.1.3.2 Other means during manufacture.** For wood products produced by other means during manu-

facture the treatment shall be an integral part of the manufacturing process of the wood product. The treatment shall provide permanent protection to all surfaces of the wood product.

**R802.1.3.3 Testing.** For wood products produced by other means during manufacture, other than a pressure process, all sides of the wood product shall be tested in accordance with and produce the results required in Section R802.1.3. Testing of only the front and back faces of wood structural panels shall be permitted.

**R802.1.3.4 Labeling.** Fire-retardant-treated lumber and wood structural panels shall be *labeled*. The *label* shall contain:

1. The identification *mark* of an *approved* agency in accordance with Section 1703.5 of the *Building Code*.
2. Identification of the treating manufacturer.
3. The name of the fire-retardant treatment.
4. The species of wood treated.
5. Flame spread index and smoke-developed index.
6. Method of drying after treatment.
7. Conformance to applicable standards in accordance with Sections R802.1.3.5 through R802.1.3.8.
8. For FRTW exposed to weather, or a damp or wet location, the words "No increase in the listed classification when subjected to the Standard Rain Test" (ASTM D 2898).

**R802.1.3.5 Strength adjustments.** Design values for untreated lumber and wood structural panels as specified in Section R802.1 shall be adjusted for fire-retardant-treated wood. Adjustments to design values shall be based upon an *approved* method of investigation which takes into consideration the effects of the anticipated temperature and humidity to which the fire-retardant-treated wood will be subjected, the type of treatment and redrying procedures.

**R802.1.3.5.1 Wood structural panels.** The effect of treatment and the method of redrying after treatment, and exposure to high temperatures and high humidities on the flexure properties of fire-retardant-treated softwood plywood shall be determined in accordance with ASTM D 5516. The test data developed by ASTM D 5516 shall be used to develop adjustment factors, maximum loads and spans, or both for untreated plywood design values in accordance with ASTM D 6305. Each manufacturer shall publish the allowable maximum loads and spans for service as floor and roof sheathing for their treatment.

**R802.1.3.5.2 Lumber.** For each species of wood treated, the effect of the treatment and the method of redrying after treatment and exposure to high temperatures and high humidities on the allowable design properties of fire-retardant-treated lumber shall be determined in accordance with ASTM D 5664. The test data developed by ASTM D 5664 shall be used to develop modification factors for use at or near room temperature and at elevated temperatures and humidity in accordance with ASTM D 6841. Each manufacturer shall publish the modification factors for service at temperatures of not less than 80°F (27°C) and for roof framing. The roof framing modification factors shall take into consideration the climatological location.

**R802.1.3.6 Exposure to weather.** Where fire-retardant-treated wood is exposed to weather or damp or wet locations, it shall be identified as “Exterior” to indicate there is no increase in the listed flame spread index as defined in Section R802.1.3 when subjected to ASTM D 2898.

**R802.1.3.7 Interior applications.** Interior fire-retardant-treated wood shall have a moisture content of not over 28 percent when tested in accordance with ASTM D 3201 procedures at 92 percent relative humidity. Interior fire-retardant-treated wood shall be tested in accordance with Section R802.1.3.5.1 or R802.1.3.5.2. Interior fire-retardant-treated wood designated as Type A shall be tested in accordance with the provisions of this section.

**R802.1.3.8 Moisture content.** Fire-retardant-treated wood shall be dried to a moisture content of 19 percent or less for lumber and 15 percent or less for wood structural panels before use. For wood kiln dried after treatment (KDAT) the kiln temperatures shall not exceed those used in kiln drying the lumber and plywood submitted for the tests described in Section R802.1.3.5.1 for plywood and R802.1.3.5.2 for lumber.

**R802.1.4 Structural glued laminated timbers.** Glued laminated timbers shall be manufactured and identified as required in ANSI/AITC A190.1 and ASTM D 3737.

**R802.1.5 Structural log members.** Stress grading of structural log members of nonrectangular shape, as typically used in log buildings, shall be in accordance with ASTM D 3957. Such structural log members shall be identified by the grade mark of an *approved* lumber grading or inspection agency. In lieu of a grade mark on the material, a certificate of inspection as to species and grade issued by a lumber-grading or inspection agency meeting the requirements of this section shall be permitted to be accepted.

**R802.2 Design and construction.** The framing details required in Section R802 apply to roofs having a minimum slope of three units vertical in 12 units horizontal (25-percent slope) or greater. Roof-ceilings shall be designed and constructed in accordance with the provisions of this chapter and Figures R606.11(1), R606.11(2) and R606.11(3) or in accordance with AFPA/NDS. Components of roof-ceilings shall be fastened in accordance with Table R602.3(1).

with AFPA/NDS. Components of roof-ceilings shall be fastened in accordance with Table R602.3(1).

**R802.3 Framing details.** Rafters shall be framed to ridge board or to each other with a gusset plate as a tie. Ridge board shall be at least 1-inch (25 mm) nominal thickness and not less in depth than the cut end of the rafter. At all valleys and hips there shall be a valley or hip rafter not less than 2-inch (51 mm) nominal thickness and not less in depth than the cut end of the rafter. Hip and valley rafters shall be supported at the ridge by a brace to a bearing partition or be designed to carry and distribute the specific load at that point. Where the roof pitch is less than three units vertical in 12 units horizontal (25-percent slope), structural members that support rafters and ceiling joists, such as ridge beams, hips and valleys, shall be designed as beams.

**R802.3.1 Ceiling joist and rafter connections.** Ceiling joists and rafters shall be nailed to each other in accordance with Table R802.5.1(9), and the rafter shall be nailed to the top wall plate in accordance with Table R602.3(1). Ceiling joists shall be continuous or securely joined in accordance with Table R802.5.1(9) where they meet over interior partitions and are nailed to adjacent rafters to provide a continuous tie across the building when such joists are parallel to the rafters.

Where ceiling joists are not connected to the rafters at the top wall plate, joists connected higher in the *attic* shall be installed as rafter ties, or rafter ties shall be installed to provide a continuous tie. Where ceiling joists are not parallel to rafters, rafter ties shall be installed. Rafter ties shall be a minimum of 2-inch by 4-inch (51 mm by 102 mm) (nominal), installed in accordance with the connection requirements in Table R802.5.1(9), or connections of equivalent capacities shall be provided. Where ceiling joists or rafter ties are not provided, the ridge formed by these rafters shall be supported by a wall or girder designed in accordance with accepted engineering practice.

Collar ties or ridge straps to resist wind uplift shall be connected in the upper third of the *attic* space in accordance with Table R602.3(1).

Collar ties shall be a minimum of 1-inch by 4-inch (25 mm by 102 mm) (nominal), spaced not more than 4 feet (1219 mm) on center.

**R802.3.2 Ceiling joists lapped.** Ends of ceiling joists shall be lapped a minimum of 3 inches (76 mm) or butted over bearing partitions or beams and toenailed to the bearing member. When ceiling joists are used to provide resistance to rafter thrust, lapped joists shall be nailed together in accordance with Table R802.5.1(9) and butted joists shall be tied together in a manner to resist such thrust.

**R802.4 Allowable ceiling joist spans.** Spans for ceiling joists shall be in accordance with Tables R802.4(1) and R802.4(2). For other grades and species and for other loading conditions, refer to the AF&PA Span Tables for Joists and Rafters.

**R802.5 Allowable rafter spans.** Spans for rafters shall be in accordance with Tables R802.5.1(1) through R802.5.1(8). For other grades and species and for other loading conditions, refer to the AF&PA Span Tables for Joists and Rafters. The span of each rafter shall be measured along the horizontal projection of the rafter.

**Exception:** Spans for rafters in accordance with WWP Western Lumber Span Tables.

**R802.5.1 Purlins.** Installation of purlins to reduce the span of rafters is permitted as shown in Figure R802.5.1. Purlins shall be sized no less than the required size of the rafters that they support. Purlins shall be continuous and shall be supported by 2-inch by 4-inch (51 mm by 102 mm) braces installed to bearing walls at a slope not less than 45 degrees from the horizontal. The braces shall be spaced not more than 4 feet (1219 mm) on center and the unbraced length of braces shall not exceed 8 feet (2438 mm).

**R802.6 Bearing.** The ends of each rafter or ceiling joist shall have not less than 1½ inches (38 mm) of bearing on wood or metal and not less than 3 inches (76 mm) on masonry or concrete.

**R802.6.1 Finished ceiling material.** If the finished ceiling material is installed on the ceiling prior to the attachment of the ceiling to the walls, such as in construction at a factory, a compression strip of the same thickness as the finish ceiling material shall be installed directly above the top plate of bearing walls if the compressive strength of the finish ceiling material is less than the loads it will be required to withstand. The compression strip shall cover the entire length of such top plate and shall be at least one-half the width of the top plate. It shall be of material capable of transmitting the loads transferred through it.

**R802.7 Cutting and notching.** Structural roof members shall not be cut, bored or notched in excess of the limitations specified in this section.

**R802.7.1 Sawn lumber.** Notches in solid lumber joists, rafters and beams shall not exceed one-sixth of the depth of the member, shall not be longer than one-third of the depth of the member and shall not be located in the middle one-third of the span. Notches at the ends of the member shall not exceed one-fourth the depth of the member. The tension side of members 4 inches (102 mm) or greater in nominal thickness shall not be notched except at the ends of the members. The diameter of the holes bored or cut into members shall not exceed one-third the depth of the member. Holes shall not be closer than 2 inches (51 mm) to the top or bottom of the member, or to any other hole located in the member. Where the member is also notched, the hole shall not be closer than 2 inches (51 mm) to the notch.

**Exception:** Notches on cantilevered portions of rafters are permitted provided the dimension of the remaining portion of the rafter is not less than 4-inch nominal (102 mm) and the length of the cantilever does not exceed 24 inches (610 mm).

**R802.7.2 Engineered wood products.** Cuts, notches and holes bored in trusses, structural composite lumber, structural glue-laminated members or I-joists are prohibited except

where permitted by the manufacturer's recommendations or where the effects of such *alterations* are specifically considered in the design of the member by a registered *design professional*.

**R802.8 Lateral support.** Roof framing members and ceiling joists having a depth-to-thickness ratio exceeding 5 to 1 based on nominal dimensions shall be provided with lateral support at points of bearing to prevent rotation. For roof rafters with ceiling joists attached per Table R602.3(1), the depth-thickness ratio for the total assembly shall be determined using the combined thickness of the rafter plus the attached ceiling joist.

**Exception:** Roof trusses shall be braced in accordance with Section R802.10.3.

**R802.8.1 Bridging.** Rafters and ceiling joists having a depth- to-thickness ratio exceeding 6 to 1 based on nominal dimensions shall be supported laterally by solid blocking, diagonal bridging (wood or metal) or a continuous 1-inch by 3-inch (25 mm by 76 mm) wood strip nailed across the rafters or ceiling joists at intervals not exceeding 8 feet (2438 mm).

**R802.9 Framing of openings.** Openings in roof and ceiling framing shall be framed with header and trimmer joists. When the header joist span does not exceed 4 feet (1219 mm), the header joist may be a single member the same size as the ceiling joist or rafter. Single trimmer joists may be used to carry a single header joist that is located within 3 feet (914 mm) of the trimmer joist bearing. When the header joist span exceeds 4 feet (1219 mm), the trimmer joists and the header joist shall be doubled and of sufficient cross section to support the ceiling joists or rafter framing into the header. *Approved* hangers shall be used for the header joist to trimmer joist connections when the header joist span exceeds 6 feet (1829 mm). Tail joists over 12 feet (3658 mm) long shall be supported at the header by framing anchors or on ledger strips not less than 2 inches by 2 inches (51 mm by 51 mm).

**R802.10 Wood trusses.**

**R802.10.1 Truss design drawings.** Truss design drawings, prepared in conformance to Section R802.10.1, shall be provided to the *building official* and *approved* prior to installation. Truss design drawings shall include, at a minimum, the information specified below. Truss design drawing shall be provided with the shipment of trusses delivered to the jobsite.

1. Slope or depth, span and spacing.
2. Location of all joints.
3. Required bearing widths.
4. Design loads as applicable.
  - 4.1. Top chord live load (as determined from Section R301.6).
  - 4.2. Top chord dead load.
  - 4.3. Bottom chord live load.
  - 4.4. Bottom chord dead load.
  - 4.5. Concentrated loads and their points of application.

- 4.6. Controlling wind and earthquake loads.
5. Adjustments to lumber and joint connector design values for conditions of use.
6. Each reaction force and direction.
7. Joint connector type and description (e.g., size, thickness or gage) and the dimensioned location of each joint connector except where symmetrically located relative to the joint interface.
8. Lumber size, species and *grade for each member*.
9. Connection requirements for:
  - 9.1. Truss to girder-truss.
  - 9.2. Truss ply to ply.
  - 9.3. Field splices.
10. Calculated deflection ratio and/or maximum description for live and total load.
11. Maximum axial compression forces in the truss members to enable the building designer to design the size, connections and anchorage of the permanent continuous lateral bracing. Forces shall be shown on the truss design drawing or on supplemental documents.
12. Required permanent truss member bracing location.

**R802.10.2 Design.** Wood trusses shall be designed in accordance with accepted engineering practice. The design and manufacture of metal-plate-connected wood trusses shall comply with ANSI/TPI 1. The truss design drawings shall be prepared by a registered professional where required by the statutes of the *jurisdiction* in which the project is to be constructed in accordance with Section R106.1.

**R802.10.2.1 Applicability limits.** The provisions of this section shall control the design of truss roof framing when snow controls for buildings not greater than 60 feet (18 288 mm) in length perpendicular to the joist, rafter or truss span, not greater than 36 feet (10 973 mm) in width parallel to the joist, rafter or truss span, not greater than two stories in height with each *story* not greater than 10

feet (3048 mm) high, and roof slopes not smaller than 3:12 (25-percent slope) or greater than 12:12 (100-percent slope). Truss roof framing constructed in accordance with the provisions of this section shall be limited to sites subjected to a maximum design wind speed of 110 miles per hour (49 m/s), Exposure A, B or C, and a maximum ground snow load of 70 psf (3352 Pa). For consistent loading of all truss types, roof snow load is to be computed as:  $0.7 p_g$ .

**R802.10.3 Bracing.** Trusses shall be braced to prevent rotation and provide lateral stability in accordance with the requirements specified in the *construction documents* for the building and on the individual truss design drawings. In the absence of specific bracing requirements, trusses shall be braced in accordance with the Building Component Safety Information (BCSI 1-03) Guide to Good Practice for Handling, Installing & Bracing of Metal Plate Connected Wood Trusses.

**R802.10.4 Alterations to trusses.** Truss members shall not be cut, notched, drilled, spliced or otherwise altered in any way without the approval of a registered *design professional*. Alterations resulting in the addition of load (e.g., HVAC equipment, water heater) that exceeds the design load for the truss shall not be permitted without verification that the truss is capable of supporting such additional loading.

**R802.10.5 Truss to wall connection.** Trusses shall be connected to wall plates by the use of *approved* connectors having a resistance to uplift of not less than 175 pounds (779 N) and shall be installed in accordance with the manufacturer's specifications. For roof assemblies subject to wind uplift pressures of 20 pounds per square foot (960 Pa) or greater, as established in Table R301.2(2), see section R802.11.

**R802.11 Roof tie-down.**

**R802.11.1 Uplift resistance.** Roof assemblies which are subject to wind uplift pressures of 20 pounds per square foot (960 Pa) or greater as established in Table R301.2(2) shall have rafter or truss ties provided at bearing locations in accordance with Table R802.11.

A continuous load path shall be designed to transmit the uplift forces from the rafter or truss ties to the foundation.

**TABLE R802.11**  
**REQUIRED STRENGTH OF TRUSS OR RAFTER TIE-DOWN CONNECTION TO RESIST WIND UPLIFT FORCES<sup>a,b,c,d</sup>**

DESIGN WIND LOAD (psf) <sup>d</sup>	TOTAL ROOF WIDTH INCLUDING OVERHANG (feet)				
	24	28	32	36	40
20	192	224	256	288	320
30	432	504	576	648	720
40	672	784	895	1,008	1,120
50	912	1,064	1,216	1,368	1,520
60	1,152	1,344	1,536	1,728	1,920

For SI: 1 inch = 25.4mm, 1 foot = 304.3 mm, 1 pound per square foot = 0.0479kN/m<sup>2</sup>, 1 pound = 0.454 kg.

a. Wind uplift forces are based on 24-inch spacing of roof trusses or rafters. For spacing other than 24 inches, forces shall be adjusted accordingly.

b. Interpolation is permitted for intermediate values of wind uplift pressures and roof widths.

c. The rated capacity of approved tie-down devices is permitted to include up to a 60-percent increase for wind effects where allowed by material specifications.

d. Figure R301.2(4) and Table R301.2(2) shall be used in determining the design wind load.

**TABLE R802.4(1)**  
**CEILING JOIST SPANS FOR COMMON LUMBER SPECIES**  
**(Uninhabitable attics without storage, live load = 10 psf, L/Δ = 240)**

CEILING JOIST SPACING (inches)	SPECIES AND GRADE	DEAD LOAD = 5 psf				
		2 x 4	2 x 6	2 x 8	2 x 10	
		Maximum ceiling joist spans				
		(feet - inches)	(feet - inches)	(feet - inches)	(feet - inches)	
12	Douglas fir-larch	SS	13-2	20-8	Note a	Note a
	Douglas fir-larch	#1	12-8	19-11	Note a	Note a
	Douglas fir-larch	#2	12-5	19-6	25-8	Note a
	Douglas fir-larch	#3	10-10	15-10	20-1	24-6
	Hem-fir	SS	12-5	19-6	25-8	Note a
	Hem-fir	#1	12-2	19-1	25-2	Note a
	Hem-fir	#2	11-7	18-2	24-0	Note a
	Hem-fir	#3	10-10	15-10	20-1	24-6
	Southern pine	SS	12-11	20-3	Note a	Note a
	Southern pine	#1	12-8	19-11	Note a	Note a
	Southern pine	#2	12-5	19-6	25-8	Note a
	Southern pine	#3	11-6	17-0	21-8	25-7
	Spruce-pine-fir	SS	12-2	19-1	25-2	Note a
	Spruce-pine-fir	#1	11-10	18-8	24-7	Note a
	Spruce-pine-fir	#2	11-10	18-8	24-7	Note a
	Spruce-pine-fir	#3	10-10	15-10	20-1	24-6
16	Douglas fir-larch	SS	11-11	18-9	24-8	Note a
	Douglas fir-larch	#1	11-6	18-1	23-10	Note a
	Douglas fir-larch	#2	11-3	17-8	23-0	Note a
	Douglas fir-larch	#3	9-5	13-9	17-5	21-3
	Hem-fir	SS	11-3	17-8	23-4	Note a
	Hem-fir	#1	11-0	17-4	22-10	Note a
	Hem-fir	#2	10-6	16-6	21-9	Note a
	Hem-fir	#3	9-5	13-9	17-5	21-3
	Southern pine	SS	11-9	18-5	24-3	Note a
	Southern pine	#1	11-6	18-1	23-1	Note a
	Southern pine	#2	11-3	17-8	23-4	Note a
	Southern pine	#3	10-0	14-9	18-9	22-2
	Spruce-pine-fir	SS	11-0	17-4	22-10	Note a
	Spruce-pine-fir	#1	10-9	16-11	22-4	Note a
	Spruce-pine-fir	#2	10-9	16-11	22-4	Note a
	Spruce-pine-fir	#3	9-5	13-9	17-5	21-3
19.2	Douglas fir-larch	SS	11-3	17-8	23-3	Note a
	Douglas fir-larch	#1	10-10	17-0	22-5	Note a
	Douglas fir-larch	#2	10-7	16-7	21-0	25-8
	Douglas fir-larch	#3	8-7	12-6	15-10	19-5
	Hem-fir	SS	10-7	16-8	21-11	Note a
	Hem-fir	#1	10-4	16-4	21-6	Note a
	Hem-fir	#2	9-11	15-7	20-6	25-3
	Hem-fir	#3	8-7	12-6	15-10	19-5
	Southern -pine	SS	11-0	17-4	22-10	Note a
	Southern pine	#1	10-10	17-0	22-5	Note a
	Southern pine	#2	10-7	16-8	21-11	Note a
	Southern pine	#3	9-1	13-6	17-2	20-3
	Spruce-pine-fir	SS	10-4	16-4	21-6	Note a
	Spruce-pine-fir	#1	10-2	15-11	21-0	25-8
	Spruce-pine-fir	#2	10-2	15-11	21-0	25-8
	Spruce-pine-fir	#3	8-7	12-6	15-10	19-5

(continued)

ROOF-CEILING CONSTRUCTION

**TABLE R802.4(1)—continued**  
**CEILING JOIST SPANS FOR COMMON LUMBER SPECIES**  
**(Uninhabitable attics without storage, live load = 10 psf, L/Δ = 240)**

CEILING JOIST SPACING (inches)	SPECIES AND GRADE		DEAD LOAD = 5 psf			
			2 x 4	2 x 6	2 x 8	2 x 10
			Maximum ceiling joist spans			
			(feet - inches)	(feet - inches)	(feet - inches)	(feet - inches)
24	Douglas fir-larch	SS	10-5	16-4	21-7	Note a
	Douglas fir-larch	#1	10-0	15-9	20-1	24-6
	Douglas fir-larch	#2	9-10	14-10	18-9	22-11
	Douglas fir-larch	#3	7-8	11-2	14-2	17-4
	Hem-fir	SS	9-10	15-6	20-5	Note a
	Hem-fir	#1	9-8	15-2	19-7	23-11
	Hem-fir	#2	9-2	14-5	18-6	22-7
	Hem-fir	#3	7-8	11-2	14-2	17-4
	Southern pine	SS	10-3	16-1	21-2	Note a
	Southern pine	#1	10-0	15-9	20-10	Note a
	Southern pine	#2	9-10	15-6	20-1	23-11
	Southern pine	#3	8-2	12-0	15-4	18-1
	Spruce-pine-fir	SS	9-8	15-2	19-11	25-5
	Spruce-pine-fir	#1	9-5	14-9	18-9	22-11
	Spruce-pine-fir	#2	9-5	14-9	18-9	22-11
	Spruce-pine-fir	#3	7-8	11-2	14-2	17-4

Check sources for availability of lumber in lengths greater than 20 feet.

For SI: 1 inch = 25.4 mm, 1 foot = 304.8 mm, 1 pound per square foot = 0.0479kPa.

a. Span exceeds 26 feet in length.

**TABLE R802.4(2)**  
**CEILING JOIST SPANS FOR COMMON LUMBER SPECIES**  
**(Uninhabitable attics with limited storage, live load = 20 psf, L/Δ = 240)**

CEILING JOIST SPACING (inches)	SPECIES AND GRADE		DEAD LOAD = 10 psf			
			2 x 4	2 x 6	2 x 8	2 x 10
			Maximum ceiling joist spans			
			(feet - inches)	(feet - inches)	(feet - inches)	(feet - inches)
12	Douglas fir-larch	SS	10-5	16-4	21-7	Note a
	Douglas fir-larch	#1	10-0	15-9	20-1	24-6
	Douglas fir-larch	#2	9-10	14-10	18-9	22-11
	Douglas fir-larch	#3	7-8	11-2	14-2	17-4
	Hem-fir	SS	9-10	15-6	20-5	Note a
	Hem-fir	#1	9-8	15-2	19-7	23-11
	Hem-fir	#2	9-2	14-5	18-6	22-7
	Hem-fir	#3	7-8	11-2	14-2	17-4
	Southern pine	SS	10-3	16-1	21-2	Note a
	Southern pine	#1	10-0	15-9	20-10	Note a
	Southern pine	#2	9-10	15-6	20-1	23-11
	Southern pine	#3	8-2	12-0	15-4	18-1
	Spruce-pine-fir	SS	9-8	15-2	19-11	25-5
	Spruce-pine-fir	#1	9-5	14-9	18-9	22-11
	Spruce-pine-fir	#2	9-5	14-9	18-9	22-11
	Spruce-pine-fir	#3	7-8	11-2	14-2	17-4
16	Douglas fir-larch	SS	9-6	14-11	19-7	25-0
	Douglas fir-larch	#1	9-1	13-9	17-5	21-3
	Douglas fir-larch	#2	8-9	12-10	16-3	19-10
	Douglas fir-larch	#3	6-8	9-8	12-4	15-0
	Hem-fir	SS	8-11	14-1	18-6	23-8
	Hem-fir	#1	8-9	13-5	16-10	20-8
	Hem-fir	#2	8-4	12-8	16-0	19-7
	Hem-fir	#3	6-8	9-8	12-4	15-0
	Southern pine	SS	9-4	14-7	19-3	24-7
	Southern pine	#1	9-1	14-4	18-11	23-1
	Southern pine	#2	8-11	13-6	17-5	20-9
	Southern pine	#3	7-1	10-5	13-3	15-8
	Spruce-pine-fir	SS	8-9	13-9	18-1	23-1
	Spruce-pine-fir	#1	8-7	12-10	16-3	19-10
	Spruce-pine-fir	#2	8-7	12-10	16-3	19-10
	Spruce-pine-fir	#3	6-8	9-8	12-4	15-0
19.2	Douglas fir-larch	SS	8-11	14-0	18-5	23-4
	Douglas fir-larch	#1	8-7	12-6	15-10	19-5
	Douglas fir-larch	#2	8-0	11-9	14-10	18-2
	Douglas fir-larch	#3	6-1	8-10	11-3	13-8
	Hem-fir	SS	8-5	13-3	17-5	22-3
	Hem-fir	#1	8-3	12-3	15-6	18-11
	Hem-fir	#2	7-10	11-7	14-8	17-10
	Hem-fir	#3	6-1	8-10	11-3	13-8
	Southern pine	SS	8-9	13-9	18-1	23-1
	Southern pine	#1	8-7	13-6	17-9	21-1
	Southern pine	#2	8-5	12-3	15-10	18-11
	Southern pine	#3	6-5	9-6	12-1	14-4
	Spruce-pine-fir	SS	8-3	12-11	17-1	21-8
	Spruce-pine-fir	#1	8-0	11-9	14-10	18-2
	Spruce-pine-fir	#2	8-0	11-9	14-10	18-2
	Spruce-pine-fir	#3	6-1	8-10	11-3	13-8

(continued)

ROOF-CEILING CONSTRUCTION

**TABLE R802.4(2)—continued**  
**CEILING JOIST SPANS FOR COMMON LUMBER SPECIES**  
 (Uninhabitable attics with limited storage, live load = 20 psf, L/Δ = 240)

CEILING JOIST SPACING (inches)	SPECIES AND GRADE		DEAD LOAD = 10 psf			
			2 x 4	2 x 6	2 x 8	2 x 10
			Maximum ceiling joist spans			
			(feet - inches)	(feet - inches)	(feet - inches)	(feet - inches)
24	Douglas fir-larch	SS	8-3	13-0	17-1	20-11
	Douglas fir-larch	#1	7-8	11-2	14-2	17-4
	Douglas fir-larch	#2	7-2	10-6	13-3	16-3
	Douglas fir-larch	#3	5-5	7-11	10-0	12-3
	Hem-fir	SS	7-10	12-3	16-2	20-6
	Hem-fir	#1	7-6	10-11	13-10	16-11
	Hem-fir	#2	7-1	10-4	13-1	16-0
	Hem-fir	#3	5-5	7-11	10-0	12-3
	Southern pine	SS	8-1	12-9	16-10	21-6
	Southern pine	#1	8-0	12-6	15-10	18-10
	Southern pine	#2	7-8	11-0	14-2	16-11
	Southern pine	#3	5-9	8-6	10-10	12-10
	Spruce-pine-fir	SS	7-8	12-0	15-10	19-5
	Spruce-pine-fir	#1	7-2	10-6	13-3	16-3
	Spruce-pine-fir	#2	7-2	10-6	13-3	16-3
	Spruce-pine-fir	#3	5-5	7-11	10-0	12-3

Check sources for availability of lumber in lengths greater than 20 feet.

For SI: 1 inch = 25.4 mm, 1 foot = 304.8 mm, 1 pound per square foot = 0.0479kPa.

a. Span exceeds 26 feet in length.



**TABLE R802.5.1(1)**  
**RAFTER SPANS FOR COMMON LUMBER SPECIES**  
 (Roof live load=20 psf, ceiling not attached to rafters, L/Δ = 180)

RAFTER SPACING (inches)	SPECIES AND GRADE		DEAD LOAD = 10 psf					DEAD LOAD = 20 psf				
			2 x 4	2 x 6	2 x 8	2 x 10	2 x 12	2 x 4	2 x 6	2 x 8	2 x 10	2 x 12
			Maximum rafter spans <sup>a</sup>									
			(feet - inches)	(feet - inches)	(feet - inches)	(feet - inches)	(feet - inches)	(feet - inches)	(feet - inches)	(feet - inches)	(feet - inches)	(feet - inches)
12	Douglas fir-larch	SS	11-6	18-0	23-9	Note b	Note b	11-6	18-0	23-5	Note b	Note b
	Douglas fir-larch	#1	11-1	17-4	22-5	Note b	Note b	10-6	15-4	19-5	23-9	Note b
	Douglas fir-larch	#2	10-10	16-7	21-0	25-8	Note b	9-10	14-4	18-2	22-3	25-9
	Douglas fir-larch	#3	8-7	12-6	15-10	19-5	22-6	7-5	10-10	13-9	16-9	19-6
	Hem-fir	SS	10-10	17-0	22-5	Note b	Note b	10-10	17-0	22-5	Note b	Note b
	Hem-fir	#1	10 -7	16-8	21-10	Note b	Note b	10-3	14-11	18-11	23-2	Note b
	Hem-fir	#2	10-1	15-11	20-8	25-3	Note b	9-8	14-2	17-11	21-11	25-5
	Hem-fir	#3	8-7	12-6	15-10	19-5	22-6	7-5	10-10	13-9	16-9	19-6
	Southern pine	SS	11-3	17-8	23-4	Note b	Note b	11-3	17-8	23-4	Note b	Note b
	Southern pine	#1	11-1	17-4	22-11	Note b	Note b	11-1	17-3	21-9	25-10	Note b
	Southern pine	#2	10-10	17-0	22-5	Note b	Note b	10-6	15-1	19-5	23-2	Note b
	Southern pine	#3	9-1	13-6	17-2	20-3	24-1	7-11	11-8	14-10	17-6	20-11
	Spruce-pine-fir	SS	10-7	16-8	21-11	Note b	Note b	10-7	16-8	21-9	Note b	Note b
	Spruce-pine-fir	#1	10-4	16-3	21-0	25-8	Note b	9-10	14-4	18-2	22-3	25-9
	Spruce-pine-fir	#2	10-4	16-3	21-0	25-8	Note b	9-10	14-4	18-2	22-3	25-9
Spruce-pine-fir	#3	8-7	12-6	15-10	19-5	22-6	7-5	10-10	13-9	16-9	19-6	
16	Douglas fir-larch	SS	10-5	16-4	21-7	Note b	Note b	10-5	16-0	20-3	24-9	Note b
	Douglas fir-larch	#1	10-0	15-4	19-5	23-9	Note b	9-1	13-3	16-10	20-7	23-10
	Douglas fir-larch	#2	9-10	14-4	18-2	22-3	25-9	8-6	12-5	15-9	19-3	22-4
	Douglas fir-larch	#3	7-5	10-10	13-9	16-9	19-6	6-5	9-5	11-11	14-6	16-10
	Hem-fir	SS	9-10	15-6	20-5	Note b	Note b	9-10	15-6	19-11	24-4	Note b
	Hem-fir	#1	9-8	14-11	18-11	23-2	Note b	8-10	12-11	16-5	20-0	23-3
	Hem-fir	#2	9-2	14-2	17-11	21-11	25-5	8-5	12-3	15-6	18-11	22-0
	Hem-fir	#3	7-5	10-10	13-9	16-9	19-6	6-5	9-5	11-11	14-6	16-10
	Southern pine	SS	10-3	16-1	21-2	Note b	Note b	10-3	16-1	21-2	Note b	Note b
	Southern pine	#1	10-0	15-9	20-10	25-10	Note b	10-0	15-0	18-10	22-4	Note b
	Southern pine	#2	9-10	15-1	19-5	23-2	Note b	9-1	13-0	16-10	20-1	23-7
	Southern pine	#3	7-11	11-8	14-10	17-6	20-11	6-10	10-1	12-10	15-2	18-1
	Spruce-pine-fir	SS	9-8	15-2	19-11	25-5	Note b	9-8	14-10	18-10	23-0	Note b
	Spruce-pine-fir	#1	9-5	14-4	18-2	22-3	25-9	8-6	12-5	15-9	19-3	22-4
	Spruce-pine-fir	#2	9-5	14-4	18-2	22-3	25-9	8-6	12-5	15-9	19-3	22-4
Spruce-pine-fir	#3	7-5	10-10	13-9	16-9	19-6	6-5	9-5	11-11	14-6	16-10	
19.2	Douglas fir-larch	SS	9-10	15-5	20-4	25-11	Note b	9-10	14-7	18-6	22-7	Note b
	Douglas fir-larch	#1	9-5	14-0	17-9	21-8	25-2	8-4	12-2	15-4	18-9	21-9
	Douglas fir-larch	#2	8-11	13-1	16-7	20-3	23-6	7-9	11-4	14-4	17-7	20-4
	Douglas fir-larch	#3	6-9	9-11	12-7	15-4	17-9	5-10	8-7	10-10	13-3	15-5
	Hem-fir	SS	9-3	14-7	19-2	24-6	Note b	9-3	14-4	18-2	22-3	25-9
	Hem-fir	#1	9-1	13-8	17-4	21-1	24-6	8-1	11-10	15-0	18-4	21-3
	Hem-fir	#2	8-8	12-11	16-4	20-0	23-2	7-8	11-2	14-2	17-4	20-1
	Hem-fir	#3	6-9	9-11	12-7	15-4	17-9	5-10	8-7	10-10	13-3	15-5
	Southern pine	SS	9-8	15-2	19-11	25-5	Note b	9-8	15-2	19-11	25-5	Note b
	Southern pine	#1	9-5	14-10	19-7	23-7	Note b	9-3	13-8	17-2	20-5	24-4
	Southern pine	#2	9-3	13-9	17-9	21-2	24-10	8-4	11-11	15-4	18-4	21-6
	Southern pine	#3	7-3	10-8	13-7	16-0	19-1	6-3	9-3	11-9	13-10	16-6
	Spruce-pine-fir	SS	9-1	14-3	18-9	23-11	Note b	9-1	13-7	17-2	21-0	24-4
	Spruce-pine-fir	#1	8-10	13-1	16-7	20-3	23-6	7-9	11-4	14-4	17-7	20-4
	Spruce-pine-fir	#2	8-10	13-1	16-7	20-3	23-6	7-9	11-4	14-4	17-7	20-4
Spruce-pine-fir	#3	6-9	9-11	12-7	15-4	17-9	5-10	8-7	10-10	13-3	15-5	

(continued)

ROOF-CEILING CONSTRUCTION

**TABLE R802.5.1(1)—continued**  
**RAFTER SPANS FOR COMMON LUMBER SPECIES**  
 (Roof live load=20 psf, ceiling not attached to rafters, L/Δ = 180)

RAFTER SPACING (inches)	SPECIES AND GRADE	DEAD LOAD = 10 psf					DEAD LOAD = 20 psf					
		2 x 4	2 x 6	2 x 8	2 x 10	2 x 12	2 x 4	2 x 6	2 x 8	2 x 10	2 x 12	
		Maximum rafter spans <sup>a</sup>										
		(feet - inches)	(feet - inches)	(feet - inches)	(feet - inches)	(feet - inches)	(feet - inches)	(feet - inches)	(feet - inches)	(feet - inches)	(feet - inches)	
24	Douglas fir-larch	SS	9-1	14-4	18-10	23-4	Note b	8-11	13-1	16-7	20-3	23-5
	Douglas fir-larch	#1	8-7	12-6	15-10	19-5	22-6	7-5	10-10	13-9	16-9	19-6
	Douglas fir-larch	#2	8-0	11-9	14-10	18-2	21-0	6-11	10-2	12-10	15-8	18-3
	Douglas fir-larch	#3	6-1	8-10	11-3	13-8	15-11	5-3	7-8	9-9	11-10	13-9
	Hem-fir	SS	8-7	13-6	17-10	22-9	Note b	8-7	12-10	16-3	19-10	23-0
	Hem-fir	#1	8-4	12-3	15-6	18-11	21-11	7-3	10-7	13-5	16-4	19-0
	Hem-fir	#2	7-11	11-7	14-8	17-10	20-9	6-10	10-0	12-8	15-6	17-11
	Hem-fir	#3	6-1	8-10	11-3	13-8	15-11	5-3	7-8	9-9	11-10	13-9
	Southern pine	SS	8-11	14-1	18-6	23-8	Note b	8-11	14-1	18-6	22-11	Note b
	Southern pine	#1	8-9	13-9	17-9	21-1	25-2	8-3	12-3	15-4	18-3	21-9
	Southern pine	#2	8-7	12-3	15-10	18-11	22-2	7-5	10-8	13-9	16-5	19-3
	Southern pine	#3	6-5	9-6	12-1	14-4	17-1	5-7	8-3	10-6	12-5	14-9
	Spruce-pine-fir	SS	8-5	13-3	17-5	21-8	25-2	8-4	12-2	15-4	18-9	21-9
	Spruce-pine-fir	#1	8-0	11-9	14-10	18-2	21-0	6-11	10-2	12-10	15-8	18-3
	Spruce-pine-fir	#2	8-0	11-9	14-10	18-2	21-0	6-11	10-2	12-10	15-8	18-3
Spruce-pine-fir	#3	6-1	8-10	11-3	13-8	15-11	5-3	7-8	9-9	11-10	13-9	

Check sources for availability of lumber in lengths greater than 20 feet.

For SI: 1 inch = 25.4 mm, 1 foot = 304.8 mm, 1 pound per square foot = 0.0479kPa.

a. The tabulated rafter spans assume that ceiling joists are located at the bottom of the attic space or that some other method of resisting the outward push of the rafters on the bearing walls, such as rafter ties, is provided at that location. When ceiling joists or rafter ties are located higher in the attic space, the rafter spans shall be multiplied by the factors given below:

$H_C/H_R$	Rafter Span Adjustment Factor
1/3	0.67
1/4	0.76
1/5	0.83
1/6	0.90
1/7.5 or less	1.00

where:

$H_C$  = Height of ceiling joists or rafter ties measured vertically above the top of the rafter support walls.

$H_R$  = Height of roof ridge measured vertically above the top of the rafter support walls.

b. Span exceeds 26 feet in length.

**TABLE R802.5.1(2)**  
**RAFTER SPANS FOR COMMON LUMBER SPECIES**  
 (Roof live load=20 psf, ceiling attached to rafters, L/Δ = 240)

RAFTER SPACING (inches)	SPECIES AND GRADE		DEAD LOAD = 10 psf					DEAD LOAD = 20 psf				
			2 x 4	2 x 6	2 x 8	2 x 10	2 x 12	2 x 4	2 x 6	2 x 8	2 x 10	2 x 12
			Maximum rafter spans <sup>a</sup>									
			(feet - inches)	(feet - inches)	(feet - inches)	(feet - inches)	(feet - inches)	(feet - inches)	(feet - inches)	(feet - inches)	(feet - inches)	(feet - inches)
12	Douglas fir-larch	SS	10-5	16-4	21-7	Note b	Note b	10-5	16-4	21-7	Note b	Note b
	Douglas fir-larch	#1	10-0	15-9	20-10	Note b	Note b	10-0	15-4	19-5	23-9	Note b
	Douglas fir-larch	#2	9-10	15-6	20-5	25-8	Note b	9-10	14-4	18-2	22-3	25-9
	Douglas fir-larch	#3	8-7	12-6	15-10	19-5	22-6	7-5	10-10	13-9	16-9	19-6
	Hem-fir	SS	9-10	15-6	20-5	Note b	Note b	9-10	15-6	20-5	Note b	Note b
	Hem-fir	#1	9-8	15-2	19-11	25-5	Note b	9-8	14-11	18-11	23-2	Note b
	Hem-fir	#2	9-2	14-5	19-0	24-3	Note b	9-2	14-2	17-11	21-11	25-5
	Hem-fir	#3	8-7	12-6	15-10	19-5	22-6	7-5	10-10	13-9	16-9	19-6
	Southern pine	SS	10-3	16-1	21-2	Note b	Note b	10-3	16-1	21-2	Note b	Note b
	Southern pine	#1	10-0	15-9	20-10	Note b	Note b	10-0	15-9	20-10	25-10	Note b
	Southern pine	#2	9-10	15-6	20-5	Note b	Note b	9-10	15-1	19-5	23-2	Note b
	Southern pine	#3	9-1	13-6	17-2	20-3	24-1	7-11	11-8	14-10	17-6	20-11
	Spruce-pine-fir	SS	9-8	15-2	19-11	25-5	Note b	9-8	15-2	19-11	25-5	Note b
	Spruce-pine-fir	#1	9-5	14-9	19-6	24-10	Note b	9-5	14-4	18-2	22-3	25-9
	Spruce-pine-fir	#2	9-5	14-9	19-6	24-10	Note b	9-5	14-4	18-2	22-3	25-9
Spruce-pine-fir	#3	8-7	12-6	15-10	19-5	22-6	7-5	10-10	13-9	16-9	19-6	
16	Douglas fir-larch	SS	9-6	14-11	19-7	25-0	Note b	9-6	14-11	19-7	24-9	Note b
	Douglas fir-larch	#1	9-1	14-4	18-11	23-9	Note b	9-1	13-3	16-10	20-7	23-10
	Douglas fir-larch	#2	8-11	14-1	18-2	22-3	25-9	8-6	12-5	15-9	19-3	22-4
	Douglas fir-larch	#3	7-5	10-10	13-9	16-9	19-6	6-5	9-5	11-11	14-6	16-10
	Hem-fir	SS	8-11	14-1	18-6	23-8	Note b	8-11	14-1	18-6	23-8	Note b
	Hem-fir	#1	8-9	13-9	18-1	23-1	Note b	8-9	12-11	16-5	20-0	23-3
	Hem-fir	#2	8-4	13-1	17-3	21-11	25-5	8-4	12-3	15-6	18-11	22-0
	Hem-fir	#3	7-5	10-10	13-9	16-9	19-6	6-5	9-5	11-11	14-6	16-10
	Southern pine	SS	9-4	14-7	19-3	24-7	Note b	9-4	14-7	19-3	24-7	Note b
	Southern pine	#1	9-1	14-4	18-11	24-1	Note b	9-1	14-4	18-10	22-4	Note b
	Southern pine	#2	8-11	14-1	18-6	23-2	Note b	8-11	13-0	16-10	20-1	23-7
	Southern pine	#3	7-11	11-8	14-10	17-6	20-11	6-10	10-1	12-10	15-2	18-1
	Spruce-pine-fir	SS	8-9	13-9	18-1	23-1	Note b	8-9	13-9	18-1	23-0	Note b
	Spruce-pine-fir	#1	8-7	13-5	17-9	22-3	25-9	8-6	12-5	15-9	19-3	22-4
	Spruce-pine-fir	#2	8-7	13-5	17-9	22-3	25-9	8-6	12-5	15-9	19-3	22-4
Spruce-pine-fir	#3	7-5	10-10	13-9	16-9	19-6	6-5	9-5	11-11	14-6	16-10	
19.2	Douglas fir-larch	SS	8-11	14-0	18-5	23-7	Note b	8-11	14-0	18-5	22-7	Note b
	Douglas fir-larch	#1	8-7	13-6	17-9	21-8	25-2	8-4	12-2	15-4	18-9	21-9
	Douglas fir-larch	#2	8-5	13-1	16-7	20-3	23-6	7-9	11-4	14-4	17-7	20-4
	Douglas fir-larch	#3	6-9	9-11	12-7	15-4	17-9	5-10	8-7	10-10	13-3	15-5
	Hem-fir	SS	8-5	13-3	17-5	22-3	Note b	8-5	13-3	17-5	22-3	25-9
	Hem-fir	#1	8-3	12-11	17-1	21-1	24-6	8-1	11-10	15-0	18-4	21-3
	Hem-fir	#2	7-10	12-4	16-3	20-0	23-2	7-8	11-2	14-2	17-4	20-1
	Hem-fir	#3	6-9	9-11	12-7	15-4	17-9	5-10	8-7	10-10	13-3	15-5
	Southern pine	SS	8-9	13-9	18-1	23-1	Note b	8-9	13-9	18-1	23-1	Note b
	Southern pine	#1	8-7	13-6	17-9	22-8	Note b	8-7	13-6	17-2	20-5	24-4
	Southern pine	#2	8-5	13-3	17-5	21-2	24-10	8-4	11-11	15-4	18-4	21-6
	Southern pine	#3	7-3	10-8	13-7	16-0	19-1	6-3	9-3	11-9	13-10	16-6
	Spruce-pine-fir	SS	8-3	12-11	17-1	21-9	Note b	8-3	12-11	17-1	21-0	24-4
	Spruce-pine-fir	#1	8-1	12-8	16-7	20-3	23-6	7-9	11-4	14-4	17-7	20-4
	Spruce-pine-fir	#2	8-1	12-8	16-7	20-3	23-6	7-9	11-4	14-4	17-7	20-4
Spruce-pine-fir	#3	6-9	9-11	12-7	15-4	17-9	5-10	8-7	10-10	13-3	15-5	

(continued)

ROOF-CEILING CONSTRUCTION

TABLE R802.5.1(2)—continued  
**RAFTER SPANS FOR COMMON LUMBER SPECIES**  
 (Roof live load=20 psf, ceiling attached to rafters, L/Δ = 240)

RAFTER SPACING (inches)	SPECIES AND GRADE	DEAD LOAD = 10 psf					DEAD LOAD = 20 psf					
		2 x 4	2 x 6	2 x 8	2 x 10	2 x 12	2 x 4	2 x 6	2 x 8	2 x 10	2 x 12	
		Maximum rafter spans <sup>a</sup>										
		(feet - inches)	(feet - inches)	(feet - inches)	(feet - inches)	(feet - inches)	(feet - inches)	(feet - inches)	(feet - inches)	(feet - inches)	(feet - inches)	
24	Douglas fir-larch	SS	8-3	13-0	17-2	21-10	Note b	8-3	13-0	16-7	20-3	23-5
	Douglas fir-larch	#1	8-0	12-6	15-10	19-5	22-6	7-5	10-10	13-9	16-9	19-6
	Douglas fir-larch	#2	7-10	11-9	14-10	18-2	21-0	6-11	10-2	12-10	15-8	18-3
	Douglas fir-larch	#3	6-1	8-10	11-3	13-8	15-11	5-3	7-8	9-9	11-10	13-9
	Hem-fir	SS	7-10	12-3	16-2	20-8	25-1	7-10	12-3	16-2	19-10	23-0
	Hem-fir	#1	7-8	12-0	15-6	18-11	21-11	7-3	10-7	13-5	16-4	19-0
	Hem-fir	#2	7-3	11-5	14-8	17-10	20-9	6-10	10-0	12-8	15-6	17-11
	Hem-fir	#3	6-1	8-10	11-3	13-8	15-11	5-3	7-8	9-9	11-10	13-9
	Southern pine	SS	8-1	12-9	16-10	21-6	Note b	8-1	12-9	16-10	21-6	Note b
	Southern pine	#1	8-0	12-6	16-6	21-1	25-2	8-0	12-3	15-4	18-3	21-9
	Southern pine	#2	7-10	12-3	15-10	18-11	22-2	7-5	10-8	13-9	16-5	19-3
	Southern pine	#3	6-5	9-6	12-1	14-4	17-1	5-7	8-3	10-6	12-5	14-9
	Spruce-pine-fir	SS	7-8	12-0	15-10	20-2	24-7	7-8	12-0	15-4	18-9	21-9
	Spruce-pine-fir	#1	7-6	11-9	14-10	18-2	21-0	6-11	10-2	12-10	15-8	18-3
	Spruce-pine-fir	#2	7-6	11-9	14-10	18-2	21-0	6-11	10-2	12-10	15-8	18-3
	Spruce-pine-fir	#3	6-1	8-10	11-3	13-8	15-11	5-3	7-8	9-9	11-10	13-9

Check sources for availability of lumber in lengths greater than 20 feet.

For SI: 1 inch = 25.4 mm, 1 foot = 304.8 mm, 1 pound per square foot = 0.0479kPa.

- a. The tabulated rafter spans assume that ceiling joists are located at the bottom of the attic space or that some other method of resisting the outward push of the rafters on the bearing walls, such as rafter ties, is provided at that location. When ceiling joists or rafter ties are located higher in the attic space, the rafter spans shall be multiplied by the factors given below:

$H_C/H_R$	Rafter Span Adjustment Factor
1/3	0.67
1/4	0.76
1/5	0.83
1/6	0.90
1/7.5 or less	1.00

where:

$H_C$  = Height of ceiling joists or rafter ties measured vertically above the top of the rafter support walls.

$H_R$  = Height of roof ridge measured vertically above the top of the rafter support walls.

- b. Span exceeds 26 feet in length.

**TABLE R802.5.1(3)**  
**RAFTER SPANS FOR COMMON LUMBER SPECIES**  
 (Ground snow load=30 psf, ceiling not attached to rafters, L/Δ = 180)

RAFTER SPACING (inches)	SPECIES AND GRADE		DEAD LOAD = 10 psf					DEAD LOAD = 20 psf				
			2 x 4	2 x 6	2 x 8	2 x 10	2 x 12	2 x 4	2 x 6	2 x 8	2 x 10	2 x 12
			Maximum rafter spans <sup>a</sup>									
			(feet - inches)	(feet - inches)	(feet - inches)	(feet - inches)	(feet - inches)	(feet - inches)	(feet - inches)	(feet - inches)	(feet - inches)	(feet - inches)
12	Douglas fir-larch	SS	10-0	15-9	20-9	Note b	Note b	10-0	15-9	20-1	24-6	Note b
	Douglas fir-larch	#1	9-8	14-9	18-8	22-9	Note b	9-0	13-2	16-8	20-4	23-7
	Douglas fir-larch	#2	9-5	13-9	17-5	21-4	24-8	8-5	12-4	15-7	19-1	22-1
	Douglas fir-larch	#3	7-1	10-5	13-2	16-1	18-8	6-4	9-4	11-9	14-5	16-8
	Hem-fir	SS	9-6	14-10	19-7	25-0	Note b	9-6	14-10	19-7	24-1	Note b
	Hem-fir	#1	9-3	14-4	18-2	22-2	25-9	8-9	12-10	16-3	19-10	23-0
	Hem-fir	#2	8-10	13-7	17-2	21-0	24-4	8-4	12-2	15-4	18-9	21-9
	Hem-fir	#3	7-1	10-5	13-2	16-1	18-8	6-4	9-4	11-9	14-5	16-8
	Southern pine	SS	9-10	15-6	20-5	Note b	Note b	9-10	15-6	20-5	Note b	Note b
	Southern pine	#1	9-8	15-2	20-0	24-9	Note b	9-8	14-10	18-8	22-2	Note b
	Southern pine	#2	9-6	14-5	18-8	22-3	Note b	9-0	12-11	16-8	19-11	23-4
	Southern pine	#3	7-7	11-2	14-3	16-10	20-0	6-9	10-0	12-9	15-1	17-11
	Spruce-pine-fir	SS	9-3	14-7	19-2	24-6	Note b	9-3	14-7	18-8	22-9	Note b
	Spruce-pine-fir	#1	9-1	13-9	17-5	21-4	24-8	8-5	12-4	15-7	19-1	22-1
	Spruce-pine-fir	#2	9-1	13-9	17-5	21-4	24-8	8-5	12-4	15-7	19-1	22-1
	Spruce-pine-fir	#3	7-1	10-5	13-2	16-1	18-8	6-4	9-4	11-9	14-5	16-8
16	Douglas fir-larch	SS	9-1	14-4	18-10	23-9	Note b	9-1	13-9	17-5	21-3	24-8
	Douglas fir-larch	#1	8-9	12-9	16-2	19-9	22-10	7-10	11-5	14-5	17-8	20-5
	Douglas fir-larch	#2	8-2	11-11	15-1	18-5	21-5	7-3	10-8	13-6	16-6	19-2
	Douglas fir-larch	#3	6-2	9-0	11-5	13-11	16-2	5-6	8-1	10-3	12-6	14-6
	Hem-fir	SS	8-7	13-6	17-10	22-9	Note b	8-7	13-6	17-1	20-10	24-2
	Hem-fir	#1	8-5	12-5	15-9	19-3	22-3	7-7	11-1	14-1	17-2	19-11
	Hem-fir	#2	8-0	11-9	14-11	18-2	21-1	7-2	10-6	13-4	16-3	18-10
	Hem-fir	#3	6-2	9-0	11-5	13-11	16-2	5-6	8-1	10-3	12-6	14-6
	Southern pine	SS	8-11	14-1	18-6	23-8	Note b	8-11	14-1	18-6	23-8	Note b
	Southern pine	#1	8-9	13-9	18-1	21-5	25-7	8-8	12-10	16-2	19-2	22-10
	Southern pine	#2	8-7	12-6	16-2	19-3	22-7	7-10	11-2	14-5	17-3	20-2
	Southern pine	#3	6-7	9-8	12-4	14-7	17-4	5-10	8-8	11-0	13-0	15-6
	Spruce-pine-fir	SS	8-5	13-3	17-5	22-1	25-7	8-5	12-9	16-2	19-9	22-10
	Spruce-pine-fir	#1	8-2	11-11	15-1	18-5	21-5	7-3	10-8	13-6	16-6	19-2
	Spruce-pine-fir	#2	8-2	11-11	15-1	18-5	21-5	7-3	10-8	13-6	16-6	19-2
	Spruce-pine-fir	#3	6-2	9-0	11-5	13-11	16-2	5-6	8-1	10-3	12-6	14-6
19.2	Douglas fir-larch	SS	8-7	13-6	17-9	21-8	25-2	8-7	12-6	15-10	19-5	22-6
	Douglas fir-larch	#1	7-11	11-8	14-9	18-0	20-11	7-1	10-5	13-2	16-1	18-8
	Douglas fir-larch	#2	7-5	10-11	13-9	16-10	19-6	6-8	9-9	12-4	15-1	17-6
	Douglas fir-larch	#3	5-7	8-3	10-5	12-9	14-9	5-0	7-4	9-4	11-5	13-2
	Hem-fir	SS	8-1	12-9	16-9	21-4	24-8	8-1	12-4	15-7	19-1	22-1
	Hem-fir	#1	7-9	11-4	14-4	17-7	20-4	6-11	10-2	12-10	15-8	18-2
	Hem-fir	#2	7-4	10-9	13-7	16-7	19-3	6-7	9-7	12-2	14-10	17-3
	Hem-fir	#3	5-7	8-3	10-5	12-9	14-9	5-0	7-4	9-4	11-5	13-2
	Southern pine	SS	8-5	13-3	17-5	22-3	Note b	8-5	13-3	17-5	22-0	25-9
	Southern pine	#1	8-3	13-0	16-6	19-7	23-4	7-11	11-9	14-9	17-6	20-11
	Southern pine	#2	7-11	11-5	14-9	17-7	20-7	7-1	10-2	13-2	15-9	18-5
	Southern pine	#3	6-0	8-10	11-3	13-4	15-10	5-4	7-11	10-1	11-11	14-2
	Spruce-pine-fir	SS	7-11	12-5	16-5	20-2	23-4	7-11	11-8	14-9	18-0	20-11
	Spruce-pine-fir	#1	7-5	10-11	13-9	16-10	19-6	6-8	9-9	12-4	15-1	17-6
	Spruce-pine-fir	#2	7-5	10-11	13-9	16-10	19-6	6-8	9-9	12-4	15-1	17-6
	Spruce-pine-fir	#3	5-7	8-3	10-5	12-9	14-9	5-0	7-4	9-4	11-5	13-2

(continued)

ROOF-CEILING CONSTRUCTION

**TABLE R802.5.1(3)—continued**  
**RAFTER SPANS FOR COMMON LUMBER SPECIES**  
 (Ground snow load=30 psf, ceiling not attached to rafters, L/Δ = 180)

RAFTER SPACING (inches)	SPECIES AND GRADE	DEAD LOAD = 10 psf					DEAD LOAD = 20 psf					
		2 x 4	2 x 6	2 x 8	2 x 10	2 x 12	2 x 4	2 x 6	2 x 8	2 x 10	2 x 12	
		Maximum rafter spans <sup>a</sup>										
		(feet - inches)	(feet - inches)	(feet - inches)	(feet - inches)	(feet - inches)	(feet - inches)	(feet - inches)	(feet - inches)	(feet - inches)	(feet - inches)	
24	Douglas fir-larch	SS	7-11	12-6	15-10	19-5	22-6	7-8	11-3	14-2	17-4	20-1
	Douglas fir-larch	#1	7-1	10-5	13-2	16-1	18-8	6-4	9-4	11-9	14-5	16-8
	Douglas fir-larch	#2	6-8	9-9	12-4	15-1	17-6	5-11	8-8	11-0	13-6	15-7
	Douglas fir-larch	#3	5-0	7-4	9-4	11-5	13-2	4-6	6-7	8-4	10-2	11-10
	Hem-fir	SS	7-6	11-10	15-7	19-1	22-1	7-6	11-0	13-11	17-0	19-9
	Hem-fir	#1	6-11	10-2	12-10	15-8	18-2	6-2	9-1	11-6	14-0	16-3
	Hem-fir	#2	6-7	9-7	12-2	14-10	17-3	5-10	8-7	10-10	13-3	15-5
	Hem-fir	#3	5-0	7-4	9-4	11-5	13-2	4-6	6-7	8-4	10-2	11-10
	Southern pine	SS	7-10	12-3	16-2	20-8	25-1	7-10	12-3	16-2	19-8	23-0
	Southern pine	#1	7-8	11-9	14-9	17-6	20-11	7-1	10-6	13-2	15-8	18-8
	Southern pine	#2	7-1	10-2	13-2	15-9	18-5	6-4	9-2	11-9	14-1	16-6
	Southern pine	#3	5-4	7-11	10-1	11-11	14-2	4-9	7-1	9-0	10-8	12-8
	Spruce-pine-fir	SS	7-4	11-7	14-9	18-0	20-11	7-1	10-5	13-2	16-1	18-8
	Spruce-pine-fir	#1	6-8	9-9	12-4	15-1	17-6	5-11	8-8	11-0	13-6	15-7
	Spruce-pine-fir	#2	6-8	9-9	12-4	15-1	17-6	5-11	8-8	11-0	13-6	15-7
	Spruce-pine-fir	#3	5-0	7-4	9-4	11-5	13-2	4-6	6-7	8-4	10-2	11-10

Check sources for availability of lumber in lengths greater than 20 feet.

For SI: 1 inch = 25.4 mm, 1 foot = 304.8 mm, 1 pound per square foot = 0.0479kPa.

- a. The tabulated rafter spans assume that ceiling joists are located at the bottom of the attic space or that some other method of resisting the outward push of the rafters on the bearing walls, such as rafter ties, is provided at that location. When ceiling joists or rafter ties are located higher in the attic space, the rafter spans shall be multiplied by the factors given below:

$H_C/H_R$	Rafter Span Adjustment Factor
1/3	0.67
1/4	0.76
1/5	0.83
1/6	0.90
1/7.5 or less	1.00

where:

$H_C$  = Height of ceiling joists or rafter ties measured vertically above the top of the rafter support walls.

$H_R$  = Height of roof ridge measured vertically above the top of the rafter support walls.

- b. Span exceeds 26 feet in length.

**TABLE R802.5.1(4)**  
**RAFTER SPANS FOR COMMON LUMBER SPECIES**  
 (Ground snow load=50 psf, ceiling not attached to rafters, L/Δ = 180)

RAFTER SPACING (inches)	SPECIES AND GRADE		DEAD LOAD = 10 psf					DEAD LOAD = 20 psf				
			2 x 4	2 x 6	2 x 8	2 x 10	2 x 12	2 x 4	2 x 6	2 x 8	2 x 10	2 x 12
			Maximum rafter spans <sup>a</sup>									
			(feet - inches)	(feet - inches)	(feet - inches)	(feet - inches)	(feet - inches)	(feet - inches)	(feet - inches)	(feet - inches)	(feet - inches)	(feet - inches)
12	Douglas fir-larch	SS	8-5	13-3	17-6	22-4	26-0	8-5	13-3	17-0	20-9	24-0
	Douglas fir-larch	#1	8-2	12-0	15-3	18-7	21-7	7-7	11-2	14-1	17-3	20-0
	Douglas fir-larch	#2	7-8	11-3	14-3	17-5	20-2	7-1	10-5	13-2	16-1	18-8
	Douglas fir-larch	#3	5-10	8-6	10-9	13-2	15-3	5-5	7-10	10-0	12-2	14-1
	Hem-fir	SS	8-0	12-6	16-6	21-1	25-6	8-0	12-6	16-6	20-4	23-7
	Hem-fir	#1	7-10	11-9	14-10	18-1	21-0	7-5	10-10	13-9	16-9	19-5
	Hem-fir	#2	7-5	11-1	14-0	17-2	19-11	7-0	10-3	13-0	15-10	18-5
	Hem-fir	#3	5-10	8-6	10-9	13-2	15-3	5-5	7-10	10-0	12-2	14-1
	Southern pine	SS	8-4	13-0	17-2	21-11	Note b	8-4	13-0	17-2	21-11	Note b
	Southern pine	#1	8-2	12-10	16-10	20-3	24-1	8-2	12-6	15-9	18-9	22-4
	Southern pine	#2	8-0	11-9	15-3	18-2	21-3	7-7	10-11	14-1	16-10	19-9
	Southern pine	#3	6-2	9-2	11-8	13-9	16-4	5-9	8-5	10-9	12-9	15-2
	Spruce-pine-fir	SS	7-10	12-3	16-2	20-8	24-1	7-10	12-3	15-9	19-3	22-4
	Spruce-pine-fir	#1	7-8	11-3	14-3	17-5	20-2	7-1	10-5	13-2	16-1	18-8
	Spruce-pine-fir	#2	7-8	11-3	14-3	17-5	20-2	7-1	10-5	13-2	16-1	18-8
	Spruce-pine-fir	#3	5-10	8-6	10-9	13-2	15-3	5-5	7-10	10-0	12-2	14-1
16	Douglas fir-larch	SS	7-8	12-1	15-10	19-5	22-6	7-8	11-7	14-8	17-11	20-10
	Douglas fir-larch	#1	7-1	10-5	13-2	16-1	18-8	6-7	9-8	12-2	14-11	17-3
	Douglas fir-larch	#2	6-8	9-9	12-4	15-1	17-6	6-2	9-0	11-5	13-11	16-2
	Douglas fir-larch	#3	5-0	7-4	9-4	11-5	13-2	4-8	6-10	8-8	10-6	12-3
	Hem-fir	SS	7-3	11-5	15-0	19-1	22-1	7-3	11-5	14-5	17-8	20-5
	Hem-fir	#1	6-11	10-2	12-10	15-8	18-2	6-5	9-5	11-11	14-6	16-10
	Hem-fir	#2	6-7	9-7	12-2	14-10	17-3	6-1	8-11	11-3	13-9	15-11
	Hem-fir	#3	5-0	7-4	9-4	11-5	13-2	4-8	6-10	8-8	10-6	12-3
	Southern pine	SS	7-6	11-10	15-7	19-11	24-3	7-6	11-10	15-7	19-11	23-10
	Southern pine	#1	7-5	11-7	14-9	17-6	20-11	7-4	10-10	13-8	16-2	19-4
	Southern pine	#2	7-1	10-2	13-2	15-9	18-5	6-7	9-5	12-2	14-7	17-1
	Southern pine	#3	5-4	7-11	10-1	11-11	14-2	4-11	7-4	9-4	11-0	13-1
	Spruce-pine-fir	SS	7-1	11-2	14-8	18-0	20-11	7-1	10-9	13-8	15-11	19-4
	Spruce-pine-fir	#1	6-8	9-9	12-4	15-1	17-6	6-2	9-0	11-5	13-11	16-2
	Spruce-pine-fir	#2	6-8	9-9	12-4	15-1	17-6	6-2	9-0	11-5	13-11	16-2
	Spruce-pine-fir	#3	5-0	7-4	9-4	11-5	13-2	4-8	6-10	8-8	10-6	12-3
19.2	Douglas fir-larch	SS	7-3	11-4	14-6	17-8	20-6	7-3	10-7	13-5	16-5	19-0
	Douglas fir-larch	#1	6-6	9-6	12-0	14-8	17-1	6-0	8-10	11-2	13-7	15-9
	Douglas fir-larch	#2	6-1	8-11	11-3	13-9	15-11	5-7	8-3	10-5	12-9	14-9
	Douglas fir-larch	#3	4-7	6-9	8-6	10-5	12-1	4-3	6-3	7-11	9-7	11-2
	Hem-fir	SS	6-10	10-9	14-2	17-5	20-2	6-10	10-5	13-2	16-1	18-8
	Hem-fir	#1	6-4	9-3	11-9	14-4	16-7	5-10	8-7	10-10	13-3	15-5
	Hem-fir	#2	6-0	8-9	11-1	13-7	15-9	5-7	8-1	10-3	12-7	14-7
	Hem-fir	#3	4-7	6-9	8-6	10-5	12-1	4-3	6-3	7-11	9-7	11-2
	Southern pine	SS	7-1	11-2	14-8	18-9	22-10	7-1	11-2	14-8	18-7	21-9
	Southern pine	#1	7-0	10-8	13-5	16-0	19-1	6-8	9-11	12-5	14-10	17-8
	Southern pine	#2	6-6	9-4	12-0	14-4	16-10	6-0	8-8	11-2	13-4	15-7
	Southern pine	#3	4-11	7-3	9-2	10-10	12-11	4-6	6-8	8-6	10-1	12-0
	Spruce-pine-fir	SS	6-8	10-6	13-5	16-5	19-1	6-8	9-10	12-5	15-3	17-8
	Spruce-pine-fir	#1	6-1	8-11	11-3	13-9	15-11	5-7	8-3	10-5	12-9	14-9
	Spruce-pine-fir	#2	6-1	8-11	11-3	13-9	15-11	5-7	8-3	10-5	12-9	14-9
	Spruce-pine-fir	#3	4-7	6-9	8-6	10-5	12-1	4-3	6-3	7-11	9-7	11-2

(continued)

ROOF-CEILING CONSTRUCTION

**TABLE R802.5.1(4)—continued**  
**RAFTER SPANS FOR COMMON LUMBER SPECIES**  
 (Ground snow load=50 psf, ceiling not attached to rafters, L/Δ = 180)

RAFTER SPACING (inches)	SPECIES AND GRADE	DEAD LOAD = 10 psf					DEAD LOAD = 20 psf					
		2 x 4	2 x 6	2 x 8	2 x 10	2 x 12	2 x 4	2 x 6	2 x 8	2 x 10	2 x 12	
		Maximum rafter spans <sup>a</sup>										
		(feet - inches)	(feet - inches)	(feet - inches)	(feet - inches)	(feet - inches)	(feet - inches)	(feet - inches)	(feet - inches)	(feet - inches)	(feet - inches)	
24	Douglas fir-larch	SS	6-8	10-	13-0	15-10	18-4	6-6	9-6	12-0	14-8	17-0
	Douglas fir-larch	#1	5-10	8-6	10-9	13-2	15-3	5-5	7-10	10-0	12-2	14-1
	Douglas fir-larch	#2	5-5	7-11	10-1	12-4	14-3	5-0	7-4	9-4	11-5	13-2
	Douglas fir-larch	#3	4-1	6-0	7-7	9-4	10-9	3-10	5-7	7-1	8-7	10-0
	Hem-fir	SS	6-4	9-11	12-9	15-7	18-0	6-4	9-4	11-9	14-5	16-8
	Hem-fir	#1	5-8	8-3	10-6	12-10	14-10	5-3	7-8	9-9	11-10	13-9
	Hem-fir	#2	5-4	7-10	9-11	12-1	14-1	4-11	7-3	9-2	11-3	13-0
	Hem-fir	#3	4-1	6-0	7-7	9-4	10-9	3-10	5-7	7-1	8-7	10-0
	Southern pine	SS	6-7	10-4	13-8	17-5	21-0	6-7	10-4	13-8	16-7	19-5
	Southern pine	#1	6-5	9-7	12-0	14-4	17-1	6-0	8-10	11-2	13-3	15-9
	Southern pine	#2	5-10	8-4	10-9	12-10	15-1	5-5	7-9	10-0	11-11	13-11
	Southern pine	#3	4-4	6-5	8-3	9-9	11-7	4-1	6-0	7-7	9-0	10-8
	Spruce-pine-fir	SS	6-2	9-6	12-0	14-8	17-1	6-0	8-10	11-2	13-7	15-9
	Spruce-pine-fir	#1	5-5	7-11	10-1	12-4	14-3	5-0	7-4	9-4	11-5	13-2
	Spruce-pine-fir	#2	5-5	7-11	10-1	12-4	14-3	5-0	7-4	9-4	11-5	13-2
	Spruce-pine-fir	#3	4-1	6-0	7-7	9-4	10-9	3-10	5-7	7-1	8-7	10-0

Check sources for availability of lumber in lengths greater than 20 feet.

For SI: 1 inch = 25.4 mm, 1 foot = 304.8 mm, 1 pound per square foot = 0.0479kPa.

- a. The tabulated rafter spans assume that ceiling joists are located at the bottom of the attic space or that some other method of resisting the outward push of the rafters on the bearing walls, such as rafter ties, is provided at that location. When ceiling joists or rafter ties are located higher in the attic space, the rafter spans shall be multiplied by the factors given below:

$H_C/H_R$	Rafter Span Adjustment Factor
1/3	0.67
1/4	0.76
1/5	0.83
1/6	0.90
1/7.5 or less	1.00

where:

$H_C$  = Height of ceiling joists or rafter ties measured vertically above the top of the rafter support walls.

$H_R$  = Height of roof ridge measured vertically above the top of the rafter support walls.

- b. Span exceeds 26 feet in length.



**TABLE R802.5.1(5)**  
**RAFTER SPANS FOR COMMON LUMBER SPECIES**  
 (Ground snow load=30 psf, ceiling attached to rafters, L/Δ = 240)

RAFTER SPACING (inches)	SPECIES AND GRADE		DEAD LOAD = 10 psf					DEAD LOAD = 20 psf				
			2 x 4	2 x 6	2 x 8	2 x 10	2 x 12	2 x 4	2 x 6	2 x 8	2 x 10	2 x 12
			Maximum rafter spans <sup>a</sup>									
			(feet - inches)	(feet - inches)	(feet - inches)	(feet - inches)	(feet - inches)	(feet - inches)	(feet - inches)	(feet - inches)	(feet - inches)	(feet - inches)
12	Douglas fir-larch	SS	9-1	14-4	18-10	24-1	Note b	9-1	14-4	18-10	24-1	Note b
	Douglas fir-larch	#1	8-9	13-9	18-2	22-9	Note b	8-9	13-2	16-8	20-4	23-7
	Douglas fir-larch	#2	8-7	13-6	17-5	21-4	24-8	8-5	12-4	15-7	19-1	22-1
	Douglas fir-larch	#3	7-1	10-5	13-2	16-1	18-8	6-4	9-4	11-9	14-5	16-8
	Hem-fir	SS	8-7	13-6	17-10	22-9	Note b	8-7	13-6	17-10	22-9	Note b
	Hem-fir	#1	8-5	13-3	17-5	22-2	25-9	8-5	12-10	16-3	19-10	23-0
	Hem-fir	#2	8-0	12-7	16-7	21-0	24-4	8-0	12-2	15-4	18-9	21-9
	Hem-fir	#3	7-1	10-5	13-2	16-1	18-8	6-4	9-4	11-9	14-5	16-8
	Southern pine	SS	8-11	14-1	18-6	23-8	Note b	8-11	14-1	18-6	23-8	Note b
	Southern pine	#1	8-9	13-9	18-2	23-2	Note b	8-9	13-9	18-2	22-2	Note b
	Southern pine	#2	8-7	13-6	17-10	22-3	Note b	8-7	12-11	16-8	19-11	23-4
	Southern pine	#3	7-7	11-2	14-3	16-10	20-0	6-9	10-0	12-9	15-1	17-11
	Spruce-pine-fir	SS	8-5	13-3	17-5	22-3	Note b	8-5	13-3	17-5	22-3	Note b
	Spruce-pine-fir	#1	8-3	12-11	17-0	21-4	24-8	8-3	12-4	15-7	19-1	22-1
	Spruce-pine-fir	#2	8-3	12-11	17-0	21-4	24-8	8-3	12-4	15-7	19-1	22-1
Spruce-pine-fir	#3	7-1	10-5	13-2	16-1	18-8	6-4	9-4	11-9	14-5	16-8	
16	Douglas fir-larch	SS	8-3	13-0	17-2	21-10	Note b	8-3	13-0	17-2	21-3	24-8
	Douglas fir-larch	#1	8-0	12-6	16-2	19-9	22-10	7-10	11-5	14-5	17-8	20-5
	Douglas fir-larch	#2	7-10	11-11	15-1	18-5	21-5	7-3	10-8	13-6	16-6	19-2
	Douglas fir-larch	#3	6-2	9-0	11-5	13-11	16-2	5-6	8-1	10-3	12-6	14-6
	Hem-fir	SS	7-10	12-3	16-2	20-8	25-1	7-10	12-3	16-2	20-8	24-2
	Hem-fir	#1	7-8	12-0	15-9	19-3	22-3	7-7	11-1	14-1	17-2	19-11
	Hem-fir	#2	7-3	11-5	14-11	18-2	21-1	7-2	10-6	13-4	16-3	18-10
	Hem-fir	#3	6-2	9-0	11-5	13-11	16-2	5-6	8-1	10-3	12-6	14-6
	Southern pine	SS	8-1	12-9	16-10	21-6	Note b	8-1	12-9	16-10	21-6	Note b
	Southern pine	#1	8-0	12-6	16-6	21-1	25-7	8-0	12-6	16-2	19-2	22-10
	Southern pine	#2	7-10	12-3	16-2	19-3	22-7	7-10	11-2	14-5	17-3	20-2
	Southern pine	#3	6-7	9-8	12-4	14-7	17-4	5-10	8-8	11-0	13-0	15-6
	Spruce-pine-fir	SS	7-8	12-0	15-10	20-2	24-7	7-8	12-0	15-10	19-9	22-10
	Spruce-pine-fir	#1	7-6	11-9	15-1	18-5	21-5	7-3	10-8	13-6	16-6	19-2
	Spruce-pine-fir	#2	7-6	11-9	15-1	18-5	21-5	7-3	10-8	13-6	16-6	19-2
Spruce-pine-fir	#3	6-2	9-0	11-5	13-11	16-2	5-6	8-1	10-3	12-6	14-6	
19.2	Douglas fir-larch	SS	7-9	12-3	16-1	20-7	25-0	7-9	12-3	15-10	19-5	22-6
	Douglas fir-larch	#1	7-6	11-8	14-9	18-0	20-11	7-1	10-5	13-2	16-1	18-8
	Douglas fir-larch	#2	7-4	10-11	13-9	16-10	19-6	6-8	9-9	12-4	15-1	17-6
	Douglas fir-larch	#3	5-7	8-3	10-5	12-9	14-9	5-0	7-4	9-4	11-5	13-2
	Hem-fir	SS	7-4	11-7	15-3	19-5	23-7	7-4	11-7	15-3	19-1	22-1
	Hem-fir	#1	7-2	11-4	14-4	17-7	20-4	6-11	10-2	12-10	15-8	18-2
	Hem-fir	#2	6-10	10-9	13-7	16-7	19-3	6-7	9-7	12-2	14-10	17-3
	Hem-fir	#3	5-7	8-3	10-5	12-9	14-9	5-0	7-4	9-4	11-5	13-2
	Southern pine	SS	7-8	12-0	15-10	20-2	24-7	7-8	12-0	15-10	20-2	24-7
	Southern pine	#1	7-6	11-9	15-6	19-7	23-4	7-6	11-9	14-9	17-6	20-11
	Southern pine	#2	7-4	11-5	14-9	17-7	20-7	7-1	10-2	13-2	15-9	18-5
	Southern pine	#3	6-0	8-10	11-3	13-4	15-10	5-4	7-11	10-1	11-11	14-2
	Spruce-pine-fir	SS	7-2	11-4	14-11	19-0	23-1	7-2	11-4	14-9	18-0	20-11
	Spruce-pine-fir	#1	7-0	10-11	13-9	16-10	19-6	6-8	9-9	12-4	15-1	17-6
	Spruce-pine-fir	#2	7-0	10-11	13-9	16-10	19-6	6-8	9-9	12-4	15-1	17-6
Spruce-pine-fir	#3	5-7	8-3	10-5	12-9	14-9	5-0	7-4	9-4	11-5	13-2	

(continued)

ROOF-CEILING CONSTRUCTION

**TABLE R802.5.1(5)—continued**  
**RAFTER SPANS FOR COMMON LUMBER SPECIES**  
 (Ground snow load=30 psf, ceiling attached to rafters, L/Δ = 240)

RAFTER SPACING (inches)	SPECIES AND GRADE	DEAD LOAD = 10 psf					DEAD LOAD = 20 psf					
		2 x 4	2 x 6	2 x 8	2 x 10	2 x 12	2 x 4	2 x 6	2 x 8	2 x 10	2 x 12	
		Maximum rafter spans <sup>a</sup>										
		(feet-inches)	(feet-inches)	(feet-inches)	(feet-inches)	(feet-inches)	(feet-inches)	(feet-inches)	(feet-inches)	(feet-inches)	(feet-inches)	(feet-inches)
24	Douglas fir-larch	SS	7-3	11-4	15-0	19-1	22-6	7-3	11-3	14-2	17-4	20-1
	Douglas fir-larch	#1	7-0	10-5	13-2	16-1	18-8	6-4	9-4	11-9	14-5	16-8
	Douglas fir-larch	#2	6-8	9-9	12-4	15-1	17-6	5-11	8-8	11-0	13-6	15-7
	Douglas fir-larch	#3	5-0	7-4	9-4	11-5	13-2	4-6	6-7	8-4	10-2	11-10
	Hem-fir	SS	6-10	10-9	14-2	18-0	21-11	6-10	10-9	13-11	17-0	19-9
	Hem-fir	#1	6-8	10-2	12-10	15-8	18-2	6-2	9-1	11-6	14-0	16-3
	Hem-fir	#2	6-4	9-7	12-2	14-10	17-3	5-10	8-7	10-10	13-3	15-5
	Hem-fir	#3	5-0	7-4	9-4	11-5	13-2	4-6	6-7	8-4	10-2	11-10
	Southern pine	SS	7-1	11-2	14-8	18-9	22-10	7-1	11-2	14-8	18-9	22-10
	Southern pine	#1	7-0	10-11	14-5	17-6	20-11	7-0	10-6	13-2	15-8	18-8
	Southern pine	#2	6-10	10-2	13-2	15-9	18-5	6-4	9-2	11-9	14-1	16-6
	Southern pine	#3	5-4	7-11	10-1	11-11	14-2	4-9	7-1	9-0	10-8	12-8
	Spruce-pine-fir	SS	6-8	10-6	13-10	17-8	20-11	6-8	10-5	13-2	16-1	18-8
	Spruce-pine-fir	#1	6-6	9-9	12-4	15-1	17-6	5-11	8-8	11-0	13-6	15-7
	Spruce-pine-fir	#2	6-6	9-9	12-4	15-1	17-6	5-11	8-8	11-0	13-6	15-7
	Spruce-pine-fir	#3	5-0	7-4	9-4	11-5	13-2	4-6	6-7	8-4	10-2	11-10

Check sources for availability of lumber in lengths greater than 20 feet.

For SI: 1 inch = 25.4 mm, 1 foot = 304.8 mm, 1 pound per square foot = 0.0479kPa.

- a. The tabulated rafter spans assume that ceiling joists are located at the bottom of the attic space or that some other method of resisting the outward push of the rafters on the bearing walls, such as rafter ties, is provided at that location. When ceiling joists or rafter ties are located higher in the attic space, the rafter spans shall be multiplied by the factors given below:

$H_C/H_R$	Rafter Span Adjustment Factor
1/3	0.67
1/4	0.76
1/5	0.83
1/6	0.90
1/7.5 or less	1.00

where:

$H_C$  = Height of ceiling joists or rafter ties measured vertically above the top of the rafter support walls.

$H_R$  = Height of roof ridge measured vertically above the top of the rafter support walls.

- b. Span exceeds 26 feet in length.

**TABLE R802.5.1(6)**  
**RAFTER SPANS FOR COMMON LUMBER SPECIES**  
 (Ground snow load=50 psf, ceiling attached to rafters, L/Δ = 240)

RAFTER SPACING (inches)	SPECIES AND GRADE		DEAD LOAD = 10 psf					DEAD LOAD = 20 psf				
			2 x 4	2 x 6	2 x 8	2 x 10	2 x 12	2 x 4	2 x 6	2 x 8	2 x 10	2 x 12
			Maximum rafter spans <sup>a</sup>									
			(feet-inches)	(feet-inches)	(feet-inches)	(feet-inches)	(feet-inches)	(feet-inches)	(feet-inches)	(feet-inches)	(feet-inches)	(feet-inches)
12	Douglas fir-larch	SS	7-8	12-1	15-11	20-3	24-8	7-8	12-1	15-11	20-3	24-0
	Douglas fir-larch	#1	7-5	11-7	15-3	18-7	21-7	7-5	11-2	14-1	17-3	20-0
	Douglas fir-larch	#2	7-3	11-3	14-3	17-5	20-2	7-1	10-5	13-2	16-1	18-8
	Douglas fir-larch	#3	5-10	8-6	10-9	13-2	15-3	5-5	7-10	10-0	12-2	14-1
	Hem-fir	SS	7-3	11-5	15-0	19-2	23-4	7-3	11-5	15-0	19-2	23-4
	Hem-fir	#1	7-1	11-2	14-8	18-1	21-0	7-1	10-10	13-9	16-9	19-5
	Hem-fir	#2	6-9	10-8	14-0	17-2	19-11	6-9	10-3	13-0	15-10	18-5
	Hem-fir	#3	5-10	8-6	10-9	13-2	15-3	5-5	7-10	10-0	12-2	14-1
	Southern pine	SS	7-6	11-10	15-7	19-11	24-3	7-6	11-10	15-7	19-11	24-3
	Southern pine	#1	7-5	11-7	15-4	19-7	23-9	7-5	11-7	15-4	18-9	22-4
	Southern pine	#2	7-3	11-5	15-0	18-2	21-3	7-3	10-11	14-1	16-10	19-9
	Southern pine	#3	6-2	9-2	11-8	13-9	16-4	5-9	8-5	10-9	12-9	15-2
	Spruce-pine-fir	SS	7-1	11-2	14-8	18-9	22-10	7-1	11-2	14-8	18-9	22-4
	Spruce-pine-fir	#1	6-11	10-11	14-3	17-5	20-2	6-11	10-5	13-2	16-1	18-8
	Spruce-pine-fir	#2	6-11	10-11	14-3	17-5	20-2	6-11	10-5	13-2	16-1	18-8
	Spruce-pine-fir	#3	5-10	8-6	10-9	13-2	15-3	5-5	7-10	10-0	12-2	14-1
16	Douglas fir-larch	SS	7-0	11-0	14-5	18-5	22-5	7-0	11-0	14-5	17-11	20-10
	Douglas fir-larch	#1	6-9	10-5	13-2	16-1	18-8	6-7	9-8	12-2	14-11	17-3
	Douglas fir-larch	#2	6-7	9-9	12-4	15-1	17-6	6-2	9-0	11-5	13-11	16-2
	Douglas fir-larch	#3	5-0	7-4	9-4	11-5	13-2	4-8	6-10	8-8	10-6	12-3
	Hem-fir	SS	6-7	10-4	13-8	17-5	21-2	6-7	10-4	13-8	17-5	20-5
	Hem-fir	#1	6-5	10-2	12-10	15-8	18-2	6-5	9-5	11-11	14-6	16-10
	Hem-fir	#2	6-2	9-7	12-2	14-10	17-3	6-1	8-11	11-3	13-9	15-11
	Hem-fir	#3	5-0	7-4	9-4	11-5	13-2	4-8	6-10	8-8	10-6	12-3
	Southern pine	SS	6-10	10-9	14-2	18-1	22-0	6-10	10-9	14-2	18-1	22-0
	Southern pine	#1	6-9	10-7	13-11	17-6	20-11	6-9	10-7	13-8	16-2	19-4
	Southern pine	#2	6-7	10-2	13-2	15-9	18-5	6-7	9-5	12-2	14-7	17-1
	Southern pine	#3	5-4	7-11	10-1	11-11	14-2	4-11	7-4	9-4	11-0	13-1
	Spruce-pine-fir	SS	6-5	10-2	13-4	17-0	20-9	6-5	10-2	13-4	16-8	19-4
	Spruce-pine-fir	#1	6-4	9-9	12-4	15-1	17-6	6-2	9-0	11-5	13-11	16-2
	Spruce-pine-fir	#2	6-4	9-9	12-4	15-1	17-6	6-2	9-0	11-5	13-11	16-2
	Spruce-pine-fir	#3	5-0	7-4	9-4	11-5	13-2	4-8	6-10	8-8	10-6	12-3
19.2	Douglas fir-larch	SS	6-7	10-4	13-7	17-4	20-6	6-7	10-4	13-5	16-5	19-0
	Douglas fir-larch	#1	6-4	9-6	12-0	14-8	17-1	6-0	8-10	11-2	13-7	15-9
	Douglas fir-larch	#2	6-1	8-11	11-3	13-9	15-11	5-7	8-3	10-5	12-9	14-9
	Douglas fir-larch	#3	4-7	6-9	8-6	10-5	12-1	4-3	6-3	7-11	9-7	11-2
	Hem-fir	SS	6-2	9-9	12-10	16-5	19-11	6-2	9-9	12-10	16-1	18-8
	Hem-fir	#1	6-1	9-3	11-9	14-4	16-7	5-10	8-7	10-10	13-3	15-5
	Hem-fir	#2	5-9	8-9	11-1	13-7	15-9	5-7	8-1	10-3	12-7	14-7
	Hem-fir	#3	4-7	6-9	8-6	10-5	12-1	4-3	6-3	7-11	9-7	11-2
	Southern pine	SS	6-5	10-2	13-4	17-0	20-9	6-5	10-2	13-4	17-0	20-9
	Southern pine	#1	6-4	9-11	13-1	16-0	19-1	6-4	9-11	12-5	14-10	17-8
	Southern pine	#2	6-2	9-4	12-0	14-4	16-10	6-0	8-8	11-2	13-4	15-7
	Southern pine	#3	4-11	7-3	9-2	10-10	12-11	4-6	6-8	8-6	10-1	12-0
	Spruce-pine-fir	SS	6-1	9-6	12-7	16-0	19-1	6-1	9-6	12-5	15-3	17-8
	Spruce-pine-fir	#1	5-11	8-11	11-3	13-9	15-11	5-7	8-3	10-5	12-9	14-9
	Spruce-pine-fir	#2	5-11	8-11	11-3	13-9	15-11	5-7	8-3	10-5	12-9	14-9
	Spruce-pine-fir	#3	4-7	6-9	8-6	10-5	12-1	4-3	6-3	7-11	9-7	11-2

(continued)

ROOF-CEILING CONSTRUCTION

**TABLE R802.5.1(6)—continued**  
**RAFTER SPANS FOR COMMON LUMBER SPECIES**  
 (Ground snow load=50 psf, ceiling attached to rafters, L/Δ = 240)

RAFTER SPACING (inches)	SPECIES AND GRADE	DEAD LOAD = 10 psf					DEAD LOAD = 20 psf					
		2 x 4	2 x 6	2 x 8	2 x 10	2 x 12	2 x 4	2 x 6	2 x 8	2 x 10	2 x 12	
		Maximum rafter spans <sup>a</sup>										
		(feet-inches)	(feet-inches)	(feet-inches)	(feet-inches)	(feet-inches)	(feet-inches)	(feet-inches)	(feet-inches)	(feet-inches)	(feet-inches)	
24	Douglas fir-larch	SS	6-1	9-7	12-7	15-10	18-4	6-1	9-6	12-0	14-8	17-0
	Douglas fir-larch	#1	5-10	8-6	10-9	13-2	15-3	5-5	7-10	10-0	12-2	14-1
	Douglas fir-larch	#2	5-5	7-11	10-1	12-4	14-3	5-0	7-4	9-4	11-5	13-2
	Douglas fir-larch	#3	4-1	6-0	7-7	9-4	10-9	3-10	5-7	7-1	8-7	10-0
	Hem-fir	SS	5-9	9-1	11-11	15-2	18-0	5-9	9-1	11-9	14-5	15-11
	Hem-fir	#1	5-8	8-3	10-6	12-10	14-10	5-3	7-8	9-9	11-10	13-9
	Hem-fir	#2	5-4	7-10	9-11	12-1	14-1	4-11	7-3	9-2	11-3	13-0
	Hem-fir	#3	4-1	6-0	7-7	9-4	10-9	3-10	5-7	7-1	8-7	10-0
	Southern pine	SS	6-0	9-5	12-5	15-10	19-3	6-0	9-5	12-5	15-10	19-3
	Southern pine	#1	5-10	9-3	12-0	14-4	17-1	5-10	8-10	11-2	13-3	15-9
	Southern pine	#2	5-9	8-4	10-9	12-10	15-1	5-5	7-9	10-0	11-11	13-11
	Southern pine	#3	4-4	6-5	8-3	9-9	11-7	4-1	6-0	7-7	9-0	10-8
	Spruce-pine-fir	SS	5-8	8-10	11-8	14-8	17-1	5-8	8-10	11-2	13-7	15-9
	Spruce-pine-fir	#1	5-5	7-11	10-1	12-4	14-3	5-0	7-4	9-4	11-5	13-2
	Spruce-pine-fir	#2	5-5	7-11	10-1	12-4	14-3	5-0	7-4	9-4	11-5	13-2
	Spruce-pine-fir	#3	4-1	6-0	7-7	9-4	10-9	3-10	5-7	7-1	8-7	10-0

Check sources for availability of lumber in lengths greater than 20 feet.

For SI: 1 inch = 25.4 mm, 1 foot = 304.8 mm, 1 pound per square foot = 0.0479 kPa.

- a. The tabulated rafter spans assume that ceiling joists are located at the bottom of the attic space or that some other method of resisting the outward push of the rafters on the bearing walls, such as rafter ties, is provided at that location. When ceiling joists or rafter ties are located higher in the attic space, the rafter spans shall be multiplied by the factors given below:

$H_C/H_R$	Rafter Span Adjustment Factor
1/3	0.67
1/4	0.76
1/5	0.83
1/6	0.90
1/7.5 or less	1.00

where:

$H_C$  = Height of ceiling joists or rafter ties measured vertically above the top of the rafter support walls.

$H_R$  = Height of roof ridge measured vertically above the top of the rafter support walls.

**TABLE R802.5.1(7)**  
**RAFTER SPANS FOR 70 PSF GROUND SNOW LOAD**  
**(Ceiling not attached to rafters, L/Δ = 180)**

RAFTER SPACING (inches)	SPECIES AND GRADE		DEAD LOAD = 10 psf					DEAD LOAD = 20 psf				
			2 x 4	2 x 6	2 x 8	2 x 10	2 x 12	2 x 4	2 x 6	2 x 8	2 x 10	2 x 12
			Maximum Rafter Spans <sup>a</sup>									
			(feet-inches)	(feet-inches)	(feet-inches)	(feet-inches)	(feet-inches)	(feet-inches)	(feet-inches)	(feet-inches)	(feet-inches)	(feet-inches)
12	Douglas fir-larch	SS	7-7	11-10	15-8	19-5	22-6	7-7	11-10	15-0	18-3	21-2
	Douglas fir-larch	#1	7-1	10-5	13-2	16-1	18-8	6-8	9-10	12-5	15-2	17-7
	Douglas fir-larch	#2	6-8	9-9	12-4	15-1	17-6	6-3	9-2	11-8	14-2	16-6
	Douglas fir-larch	#3	5-0	7-4	9-4	11-5	13-2	4-9	6-11	8-9	10-9	12-5
	Hem-fir	SS	7-2	11-3	14-9	18-10	22-1	7-2	11-3	14-8	18-0	20-10
	Hem-fir	#1	6-11	10-2	12-10	15-8	18-2	6-6	9-7	12-1	14-10	17-2
	Hem-fir	#2	6-7	9-7	12-2	14-10	17-3	6-2	9-1	11-5	14-0	16-3
	Hem-fir	#3	5-0	7-4	9-4	11-5	13-2	4-9	6-11	8-9	10-9	12-5
	Southern pine	SS	7-5	11-8	15-4	19-7	23-10	7-5	11-8	15-4	19-7	23-10
	Southern pine	#1	7-3	11-5	14-9	17-6	20-11	7-3	11-1	13-11	16-6	19-8
	Southern pine	#2	7-1	10-2	13-2	15-9	18-5	6-8	9-7	12-5	14-10	17-5
	Southern pine	#3	5-4	7-11	10-1	11-11	14-2	5-1	7-5	9-6	11-3	13-4
	Spruce-pine-fir	SS	7-0	11-0	14-6	18-0	20-11	7-0	11-0	13-11	17-0	19-8
	Spruce-pine-fir	#1	6-8	9-9	12-4	15-1	17-6	6-3	9-2	11-8	14-2	16-6
	Spruce-pine-fir	#2	6-8	9-9	12-4	15-1	17-6	6-3	9-2	11-8	14-2	16-6
	Spruce-pine-fir	#3	5-0	7-4	9-4	11-5	13-2	4-9	6-11	8-9	10-9	12-5
16	Douglas fir-larch	SS	6-10	10-9	13-9	16-10	19-6	6-10	10-3	13-0	15-10	18-4
	Douglas fir-larch	#1	6-2	9-0	11-5	13-11	16-2	5-10	8-6	10-9	13-2	15-3
	Douglas fir-larch	#2	5-9	8-5	10-8	13-1	15-2	5-5	7-11	10-1	12-4	14-3
	Douglas fir-larch	#3	4-4	6-4	8-1	9-10	11-5	4-1	6-0	7-7	9-4	10-9
	Hem-fir	SS	6-6	10-2	13-5	16-6	19-2	6-6	10-1	12-9	15-7	18-0
	Hem-fir	#1	6-0	8-9	11-2	13-7	15-9	5-8	8-3	10-6	12-10	14-10
	Hem-fir	#2	5-8	8-4	10-6	12-10	14-11	5-4	7-10	9-11	12-1	14-1
	Hem-fir	#3	4-4	6-4	8-1	9-10	11-5	4-1	6-0	7-7	9-4	10-9
	Southern pine	SS	6-9	10-7	14-0	17-10	21-8	6-9	10-7	14-0	17-10	21-0
	Southern pine	#1	6-7	10-2	12-9	15-2	18-1	6-5	9-7	12-0	14-4	17-1
	Southern pine	#2	6-2	8-10	11-5	13-7	16-0	5-10	8-4	10-9	12-10	15-1
	Southern pine	#3	4-8	6-10	8-9	10-4	12-3	4-4	6-5	8-3	9-9	11-7
	Spruce-pine-fir	SS	6-4	10-0	12-9	15-7	18-1	6-4	9-6	12-0	14-8	17-1
	Spruce-pine-fir	#1	5-9	8-5	10-8	13-1	15-2	5-5	7-11	10-1	12-4	14-3
	Spruce-pine-fir	#2	5-9	8-5	10-8	13-1	15-2	5-5	7-11	10-1	12-4	14-3
	Spruce-pine-fir	#3	4-4	6-4	8-1	9-10	11-5	4-1	6-0	7-7	9-4	10-9
19.2	Douglas fir-larch	SS	6-5	9-11	12-7	15-4	17-9	6-5	9-4	11-10	14-5	16-9
	Douglas fir-larch	#1	5-7	8-3	10-5	12-9	14-9	5-4	7-9	9-10	12-0	13-11
	Douglas fir-larch	#2	5-3	7-8	9-9	11-11	13-10	5-0	7-3	9-2	11-3	13-0
	Douglas fir-larch	#3	4-0	5-10	7-4	9-0	10-5	3-9	5-6	6-11	8-6	9-10
	Hem-fir	SS	6-1	9-7	12-4	15-1	17-4	6-1	9-2	11-8	14-2	15-5
	Hem-fir	#1	5-6	8-0	10-2	12-5	14-5	5-2	7-7	9-7	11-8	13-7
	Hem-fir	#2	5-2	7-7	9-7	11-9	13-7	4-11	7-2	9-1	11-1	12-10
	Hem-fir	#3	4-0	5-10	7-4	9-0	10-5	3-9	5-6	6-11	8-6	9-10
	Southern pine	SS	6-4	10-0	13-2	16-9	20-4	6-4	10-0	13-2	16-5	19-2
	Southern pine	#1	6-3	9-3	11-8	13-10	16-6	5-11	8-9	11-0	13-1	15-7
	Southern pine	#2	5-7	8-1	10-5	12-5	14-7	5-4	7-7	9-10	11-9	13-9
	Southern pine	#3	4-3	6-3	8-0	9-5	11-2	4-0	5-11	7-6	8-10	10-7
	Spruce-pine-fir	SS	6-0	9-2	11-8	14-3	16-6	5-11	8-8	11-0	13-5	15-7
	Spruce-pine-fir	#1	5-3	7-8	9-9	11-11	13-10	5-0	7-3	9-2	11-3	13-0
	Spruce-pine-fir	#2	5-3	7-8	9-9	11-11	13-10	5-0	7-3	9-2	11-3	13-0
	Spruce-pine-fir	#3	4-0	5-10	7-4	9-0	10-5	3-9	5-6	6-11	8-6	9-10

(continued)

ROOF-CEILING CONSTRUCTION

TABLE R802.5.1(7)—continued  
**RAFTER SPANS FOR 70 PSF GROUND SNOW LOAD**  
 (Ceiling not attached to rafters,  $L/\Delta = 180$ )

RAFTER SPACING (inches)	SPECIES AND GRADE	DEAD LOAD = 10 psf					DEAD LOAD = 20 psf					
		2 x 4	2 x 6	2 x 8	2 x 10	2 x 12	2 x 4	2 x 6	2 x 8	2 x 10	2 x 12	
		Maximum rafter spans <sup>a</sup>										
		(feet - inches)	(feet - inches)	(feet - inches)	(feet - inches)	(feet - inches)	(feet - inches)	(feet - inches)	(feet - inches)	(feet - inches)	(feet - inches)	
24	Douglas fir-larch	SS	6-0	8-10	11-3	13-9	15-11	5-9	8-4	10-7	12-11	15-0
	Douglas fir-larch	#1	5-0	7-4	9-4	11-5	13-2	4-9	6-11	8-9	10-9	12-5
	Douglas fir-larch	#2	4-8	6-11	8-9	10-8	12-4	4-5	6-6	8-3	10-0	11-8
	Douglas fir-larch	#3	3-7	5-2	6-7	8-1	9-4	3-4	4-11	6-3	7-7	8-10
	Hem-fir	SS	5-8	8-8	11-0	13-6	13-11	5-7	8-3	10-5	12-4	12-4
	Hem-fir	#1	4-11	7-2	9-1	11-1	12-10	4-7	6-9	8-7	10-6	12-2
	Hem-fir	#2	4-8	6-9	8-7	10-6	12-2	4-4	6-5	8-1	9-11	11-6
	Hem-fir	#3	3-7	5-2	6-7	8-1	9-4	3-4	4-11	6-3	7-7	8-10
	Southern pine	SS	5-11	9-3	12-2	15-7	18-2	5-11	9-3	12-2	14-8	17-2
	Southern pine	#1	5-7	8-3	10-5	12-5	14-9	5-3	7-10	9-10	11-8	13-11
	Southern pine	#2	5-0	7-3	9-4	11-1	13-0	4-9	6-10	8-9	10-6	12-4
	Southern pine	#3	3-9	5-7	7-1	8-5	10-0	3-7	5-3	6-9	7-11	9-5
	Spruce-pine-fir	SS	5-6	8-3	10-5	12-9	14-9	5-4	7-9	9-10	12-0	12-11
	Spruce-pine-fir	#1	4-8	6-11	8-9	10-8	12-4	4-5	6-6	8-3	10-0	11-8
	Spruce-pine-fir	#2	4-8	6-11	8-9	10-8	12-4	4-5	6-6	8-3	10-0	11-8
	Spruce-pine-fir	#3	3-7	5-2	6-7	8-1	9-4	3-4	4-11	6-3	7-7	8-10

Check sources for availability of lumber in lengths greater than 20 feet.

For SI: 1 inch = 25.4 mm, 1 foot = 304.8 mm, 1 pound per square foot = 0.0479kPa.

- a. The tabulated rafter spans assume that ceiling joists are located at the bottom of the attic space or that some other method of resisting the outward push of the rafters on the bearing walls, such as rafter ties, is provided at that location. When ceiling joists or rafter ties are located higher in the attic space, the rafter spans shall be multiplied by the factors given below:

$H_C/H_R$	Rafter Span Adjustment Factor
1/3	0.67
1/4	0.76
1/5	0.83
1/6	0.90
1/7.5 or less	1.00

where:

$H_C$  = Height of ceiling joists or rafter ties measured vertically above the top of the rafter support walls.

$H_R$  = Height of roof ridge measured vertically above the top of the rafter support walls.

**TABLE R802.5.1(8)**  
**RAFTER SPANS FOR 70 PSF GROUND SNOW LOAD**  
**(Ceiling attached to rafters, L/Δ = 240)**

RAFTER SPACING (inches)	SPECIES AND GRADE	DEAD LOAD = 10 psf					DEAD LOAD = 20 psf					
		2 x 4	2 x 6	2 x 8	2 x 10	2 x 12	2 x 4	2 x 6	2 x 8	2 x 10	2 x 12	
		Maximum rafter spans <sup>a</sup>										
		(feet - inches)	(feet - inches)	(feet - inches)	(feet - inches)	(feet - inches)	(feet - inches)	(feet - inches)	(feet - inches)	(feet - inches)	(feet - inches)	(feet - inches)
12	Douglas fir-larch	SS	6-10	10-9	14-3	18-2	22-1	6-10	10-9	14-3	18-2	21-2
	Douglas fir-larch	#1	6-7	10-5	13-2	16-1	18-8	6-7	9-10	12-5	15-2	17-7
	Douglas fir-larch	#2	6-6	9-9	12-4	15-1	17-6	6-3	9-2	11-8	14-2	16-6
	Douglas fir-larch	#3	5-0	7-4	9-4	11-5	13-2	4-9	6-11	8-9	10-9	12-5
	Hem-fir	SS	6-6	10-2	13-5	17-2	20-10	6-6	10-2	13-5	17-2	20-10
	Hem-fir	#1	6-4	10-0	12-10	15-8	18-2	6-4	9-7	12-1	14-10	17-2
	Hem-fir	#2	6-1	9-6	12-2	14-10	17-3	6-1	9-1	11-5	14-0	16-3
	Hem-fir	#3	5-0	7-4	9-4	11-5	13-2	4-9	6-11	8-9	10-9	12-5
	Southern pine	SS	6-9	10-7	14-0	17-10	21-8	6-9	10-7	14-0	17-10	21-8
	Southern pine	#1	6-7	10-5	13-8	17-6	20-11	6-7	10-5	13-8	16-6	19-8
	Southern pine	#2	6-6	10-2	13-2	15-9	18-5	6-6	9-7	12-5	14-10	17-5
	Southern pine	#3	5-4	7-11	10-1	11-11	14-2	5-1	7-5	9-6	11-3	13-4
	Spruce-pine-fir	SS	6-4	10-0	13-2	16-9	20-5	6-4	10-0	13-2	16-9	19-8
	Spruce-pine-fir	#1	6-2	9-9	12-4	15-1	17-6	6-2	9-2	11-8	14-2	16-6
	Spruce-pine-fir	#2	6-2	9-9	12-4	15-1	17-6	6-2	9-2	11-8	14-2	16-6
	Spruce-pine-fir	#3	5-0	7-4	9-4	11-5	13-2	4-9	6-11	8-9	10-9	12-5
16	Douglas fir-larch	SS	6-3	9-10	12-11	16-6	19-6	6-3	9-10	12-11	15-10	18-4
	Douglas fir-larch	#1	6-0	9-0	11-5	13-11	16-2	5-10	8-6	10-9	13-2	15-3
	Douglas fir-larch	#2	5-9	8-5	10-8	13-1	15-2	5-5	7-11	10-1	12-4	14-3
	Douglas fir-larch	#3	4-4	6-4	8-1	9-10	11-5	4-1	6-0	7-7	9-4	10-9
	Hem-fir	SS	5-11	9-3	12-2	15-7	18-11	5-11	9-3	12-2	15-7	18-0
	Hem-fir	#1	5-9	8-9	11-2	13-7	15-9	5-8	8-3	10-6	12-10	14-10
	Hem-fir	#2	5-6	8-4	10-6	12-10	14-11	5-4	7-10	9-11	12-1	14-1
	Hem-fir	#3	4-4	6-4	8-1	9-10	11-5	4-1	6-0	7-7	9-4	10-9
	Southern pine	SS	6-1	9-7	12-8	16-2	19-8	6-1	9-7	12-8	16-2	19-8
	Southern pine	#1	6-0	9-5	12-5	15-2	18-1	6-0	9-5	12-0	14-4	17-1
	Southern pine	#2	5-11	8-10	11-5	13-7	16-0	5-10	8-4	10-9	12-10	15-1
	Southern pine	#3	4-8	6-10	8-9	10-4	12-3	4-4	6-5	8-3	9-9	11-7
	Spruce-pine-fir	SS	5-9	9-1	11-11	15-3	18-1	5-9	9-1	11-11	14-8	17-1
	Spruce-pine-fir	#1	5-8	8-5	10-8	13-1	15-2	5-5	7-11	10-1	12-4	14-3
	Spruce-pine-fir	#2	5-8	8-5	10-8	13-1	15-2	5-5	7-11	10-1	12-4	14-3
	Spruce-pine-fir	#3	4-4	6-4	8-1	9-10	11-5	4-1	6-0	7-7	9-4	10-9
19.2	Douglas fir-larch	SS	5-10	9-3	12-2	15-4	17-9	5-10	9-3	11-10	14-5	16-9
	Douglas fir-larch	#1	5-7	8-3	10-5	12-9	14-9	5-4	7-9	9-10	12-0	13-11
	Douglas fir-larch	#2	5-3	7-8	9-9	11-11	13-10	5-0	7-3	9-2	11-3	13-0
	Douglas fir-larch	#3	4-0	5-10	7-4	9-0	10-5	3-9	5-6	6-11	8-6	9-10
	Hem-fir	SS	5-6	8-8	11-6	14-8	17-4	5-6	8-8	11-6	14-2	15-5
	Hem-fir	#1	5-5	8-0	10-2	12-5	14-5	5-2	7-7	9-7	11-8	13-7
	Hem-fir	#2	5-2	7-7	9-7	11-9	13-7	4-11	7-2	9-1	11-1	12-10
	Hem-fir	#3	4-0	5-10	7-4	9-0	10-5	3-9	5-6	6-11	8-6	9-10
	Southern pine	SS	5-9	9-1	11-11	15-3	18-6	5-9	9-1	11-11	15-3	18-6
	Southern pine	#1	5-8	8-11	11-8	13-10	16-6	5-8	8-9	11-0	13-1	15-7
	Southern pine	#2	5-6	8-1	10-5	12-5	14-7	5-4	7-7	9-10	11-9	13-9
	Southern pine	#3	4-3	6-3	8-0	9-5	11-2	4-0	5-11	7-6	8-10	10-7
	Spruce-pine-fir	SS	5-5	8-6	11-3	14-3	16-6	5-5	8-6	11-0	13-5	15-7
	Spruce-pine-fir	#1	5-3	7-8	9-9	11-11	13-10	5-0	7-3	9-2	11-3	13-0
	Spruce-pine-fir	#2	5-3	7-8	9-9	11-11	13-10	5-0	7-3	9-2	11-3	13-0
	Spruce-pine-fir	#3	4-0	5-10	7-4	9-0	10-5	3-9	5-6	6-11	8-6	9-10

(continued)

ROOF-CEILING CONSTRUCTION

TABLE R802.5.1(8)—continued  
**RAFTER SPANS FOR 70 PSF GROUND SNOW LOAD<sup>a</sup>**  
 (Ceiling attached to rafters,  $L/\Delta = 240$ )

RAFTER SPACING (inches)	SPECIES AND GRADE	DEAD LOAD = 10 psf					DEAD LOAD = 20 psf					
		2 x 4	2 x 6	2 x 8	2 x 10	2 x 12	2 x 4	2 x 6	2 x 8	2 x 10	2 x 12	
		Maximum rafter spans <sup>a</sup>										
		(feet - inches)	(feet - inches)	(feet - inches)	(feet - inches)	(feet - inches)	(feet - inches)	(feet - inches)	(feet - inches)	(feet - inches)	(feet - inches)	(feet - inches)
24	Douglas fir-larch	SS	5-5	8-7	11-3	13-9	15-11	5-5	8-4	10-7	12-11	15-0
	Douglas fir-larch	#1	5-0	7-4	9-4	11-5	13-2	4-9	6-11	8-9	10-9	12-5
	Douglas fir-larch	#2	4-8	6-11	8-9	10-8	12-4	4-5	6-6	8-3	10-0	11-8
	Douglas fir-larch	#3	3-7	5-2	6-7	8-1	9-4	3-4	4-11	6-3	7-7	8-10
	Hem-fir	SS	5-2	8-1	10-8	13-6	13-11	5-2	8-1	10-5	12-4	12-4
	Hem-fir	#1	4-11	7-2	9-1	11-1	12-10	4-7	6-9	8-7	10-6	12-2
	Hem-fir	#2	4-8	6-9	8-7	10-6	12-2	4-4	6-5	8-1	9-11	11-6
	Hem-fir	#3	3-7	5-2	6-7	8-1	9-4	3-4	4-11	6-3	7-7	8-10
	Southern pine	SS	5-4	8-5	11-1	14-2	17-2	5-4	8-5	11-1	14-2	17-2
	Southern pine	#1	5-3	8-3	10-5	12-5	14-9	5-3	7-10	9-10	11-8	13-11
	Southern pine	#2	5-0	7-3	9-4	11-1	13-0	4-9	6-10	8-9	10-6	12-4
	Southern pine	#3	3-9	5-7	7-1	8-5	10-0	3-7	5-3	6-9	7-11	9-5
	Spruce-pine-fir	SS	5-0	7-11	10-5	12-9	14-9	5-0	7-9	9-10	12-0	12-11
	Spruce-pine-fir	#1	4-8	6-11	8-9	10-8	12-4	4-5	6-6	8-3	10-0	11-8
	Spruce-pine-fir	#2	4-8	6-11	8-9	10-8	12-4	4-5	6-6	8-3	10-0	11-8
	Spruce-pine-fir	#3	3-7	5-2	6-7	8-1	9-4	3-4	4-11	6-3	7-7	8-10

Check sources for availability of lumber in lengths greater than 20 feet.

For SI: 1 inch = 25.4 mm, 1 foot = 304.8 mm, 1 pound per square foot = 0.0479 kPa.

- a. The tabulated rafter spans assume that ceiling joists are located at the bottom of the attic space or that some other method of resisting the outward push of the rafters on the bearing walls, such as rafter ties, is provided at that location. When ceiling joists or rafter ties are located higher in the attic space, the rafter spans shall be multiplied by the factors given below:

$H_C/H_R$	Rafter Span Adjustment Factor
1/3	0.67
1/4	0.76
1/5	0.83
1/6	0.90
1/7.5 or less	1.00

where:

$H_C$  = Height of ceiling joists or rafter ties measured vertically above the top of the rafter support walls.

$H_R$  = Height of roof ridge measured vertically above the top of the rafter support walls.



**TABLE R802.5.1(9)**  
**RAFTER/CEILING JOIST HEEL JOINT CONNECTIONS<sup>a, b, c, d, e, f, h</sup>**

RAFTER SLOPE	RAFTER SPACING (inches)	GROUND SNOW LOAD (psf)															
		20 <sup>g</sup>				30				50				70			
		Roof span (feet)															
		12	20	28	36	12	20	28	36	12	20	28	36	12	20	28	36
Required number of 16d common nails <sup>a, b</sup> per heel joint splices <sup>c, d, e, f</sup>																	
3:12	12	4	6	8	10	4	6	8	11	5	8	12	15	6	11	15	20
	16	5	8	10	13	5	8	11	14	6	11	15	20	8	14	20	26
	24	7	11	15	19	7	11	16	21	9	16	23	30	12	21	30	39
4:12	12	3	5	6	8	3	5	6	8	4	6	9	11	5	8	12	15
	16	4	6	8	10	4	6	8	11	5	8	12	15	6	11	15	20
	24	5	8	12	15	5	9	12	16	7	12	17	22	9	16	23	29
5:12	12	3	4	5	6	3	4	5	7	3	5	7	9	4	7	9	12
	16	3	5	6	8	3	5	7	9	4	7	9	12	5	9	12	16
	24	4	7	9	12	4	7	10	13	6	10	14	18	7	13	18	23
7:12	12	3	4	4	5	3	3	4	5	3	4	5	7	3	5	7	9
	16	3	4	5	6	3	4	5	6	3	5	7	9	4	6	9	11
	24	3	5	7	9	3	5	7	9	4	7	10	13	5	9	13	17
9:12	12	3	3	4	4	3	3	3	4	3	3	4	5	3	4	5	7
	16	3	4	4	5	3	3	4	5	3	4	5	7	3	5	7	9
	24	3	4	6	7	3	4	6	7	3	6	8	10	4	7	10	13
12:12	12	3	3	3	3	3	3	3	3	3	3	3	4	3	3	4	5
	16	3	3	4	4	3	3	3	4	3	3	4	5	3	4	5	7
	24	3	4	4	5	3	3	4	6	3	4	6	8	3	6	8	10

For SI: 1 inch = 25.4 mm, 1 foot = 304.8 mm, 1 pound per square foot = 0.0479kPa.

- a. 40d box nails shall be permitted to be substituted for 16d common nails.
- b. Nailing requirements shall be permitted to be reduced 25 percent if nails are clinched.
- c. Heel joint connections are not required when the ridge is supported by a load-bearing wall, header or ridge beam.
- d. When intermediate support of the rafter is provided by vertical struts or purlins to a loadbearing wall, the tabulated heel joint connection requirements shall be permitted to be reduced proportionally to the reduction in span.
- e. Equivalent nailing patterns are required for ceiling joist to ceiling joist lap splices.
- f. When rafter ties are substituted for ceiling joists, the heel joint connection requirement shall be taken as the tabulated heel joint connection requirement for two-thirds of the actual rafter-slope.
- g. Applies to roof live load of 20 psf or less.
- h. Tabulated heel joint connection requirements assume that ceiling joists or rafter ties are located at the bottom of the attic space. When ceiling joists or rafter ties are located higher in the attic, heel joint connection requirements shall be increased by the following factors:

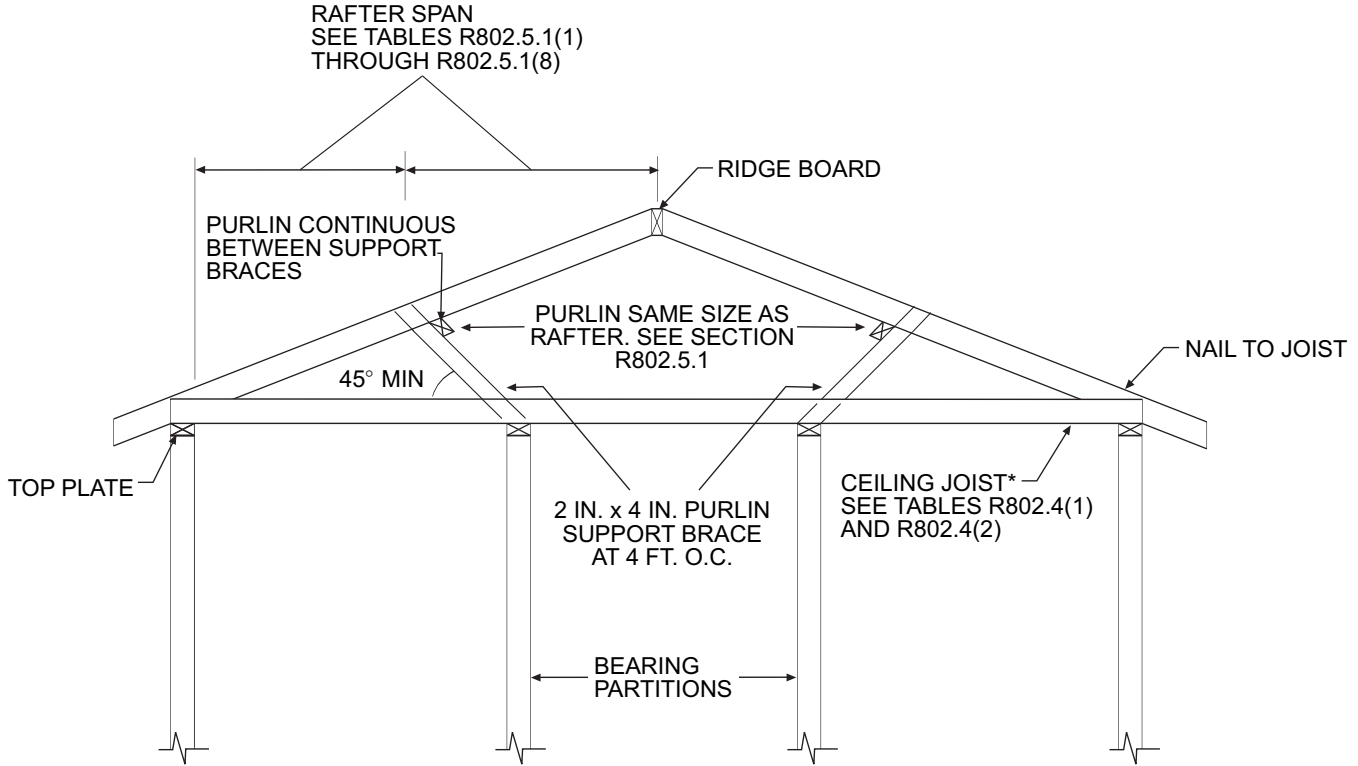
$H_C/H_R$	Heel Joint Connection Adjustment Factor
1/3	1.5
1/4	1.33
1/5	1.25
1/6	1.2
1/10 or less	1.11

where:

$H_C$  = Height of ceiling joists or rafter ties measured vertically above the top of the rafter support walls.

$H_R$  = Height of roof ridge measured vertically above the top of the rafter support walls.

**ROOF-CEILING CONSTRUCTION**



For SI: 1 inch = 25.4 mm, 1 foot = 305 mm, 1 degree = 0.018 rad.

**Note:** Where ceiling joints run perpendicular to the rafters, rafter ties shall be nailed to each rafter near the top of the ceiling joist.

**FIGURE R802.5.1  
BRACED RAFTER CONSTRUCTION**

**TABLE R802.11  
REQUIRED STRENGTH OF TRUSS OR RAFTER CONNECTIONS TO RESIST WIND UPLIFT FORCES<sup>a, b, c, e, f</sup>  
(Pounds per connection)**

BASIC WIND SPEED (mph) (3-second gust)	ROOF SPAN (feet)							OVERHANGS <sup>d</sup> (pounds/foot)
	12	20	24	28	32	36	40	
85	-72	-120	-145	-169	-193	-217	-241	-38.55
90	-91	-151	-181	-212	-242	-272	-302	-43.22
100	-131	-218	-262	-305	-349	-393	-436	-53.36
110	-175	-292	-351	-409	-467	-526	-584	-64.56

For SI: 1 inch = 25.4 mm, 1 foot = 305 mm, 1 mph = 0.447 m/s, 1 pound/foot = 14.5939 N/m, 1 pound = 0.454 kg.

- The uplift connection requirements are based on a 30 foot mean roof height located in Exposure B. For Exposures C and D and for other mean roof heights, multiply the above loads by the Adjustment Coefficients in Table R301.2(3).
- The uplift connection requirements are based on the framing being spaced 24 inches on center. Multiply by 0.67 for framing spaced 16 inches on center and multiply by 0.5 for framing spaced 12 inches on center.
- The uplift connection requirements include an allowance for 10 pounds of dead load.
- The uplift connection requirements do not account for the effects of overhangs. The magnitude of the above loads shall be increased by adding the overhang loads found in the table. The overhang loads are also based on framing spaced 24 inches on center. The overhang loads given shall be multiplied by the overhang projection and added to the roof uplift value in the table.
- The uplift connection requirements are based on wind loading on end zones as defined in Figure 6-2 of ASCE 7. Connection loads for connections located a distance of 20% of the least horizontal dimension of the building from the corner of the building are permitted to be reduced by multiplying the table connection value by 0.7 and multiplying the overhang load by 0.8.
- For wall-to-wall and wall-to-foundation connections, the capacity of the uplift connector is permitted to be reduced by 100 pounds for each full wall above. (For example, if a 600-pound rated connector is used on the roof framing, a 500-pound rated connector is permitted at the next floor level down).

**SECTION R803  
ROOF SHEATHING**

**R803.1 Lumber sheathing.** Allowable spans for lumber used as roof sheathing shall conform to Table R803.1. Spaced lumber sheathing for wood shingle and shake roofing shall conform to the requirements of Sections R905.7 and R905.8. Spaced lumber sheathing is not allowed in Seismic Design Category D<sub>2</sub>.

**TABLE R803.1  
MINIMUM THICKNESS OF LUMBER ROOF SHEATHING**

RAFTER OR BEAM SPACING (inches)	MINIMUM NET THICKNESS (inches)
24	<sup>5</sup> / <sub>8</sub>
48 <sup>a</sup>	1½ T & G
60 <sup>b</sup>	
72 <sup>c</sup>	

For SI: 1 inch = 25.4 mm.

- a. Minimum 270 F<sub>b</sub>, 340,000 E.
- b. Minimum 420 F<sub>b</sub>, 660,000 E.
- c. Minimum 600 F<sub>b</sub>, 1,150,000 E.

**R803.2 Wood structural panel sheathing.**

**R803.2.1 Identification and grade.** Wood structural panels shall conform to DOC PS 1, DOC PS 2 or, when manufactured in Canada, CSA O437 or CSA O325, and shall be identified by a grade mark or certificate of inspection issued by an *approved* agency. Wood structural panels shall comply with the grades specified in Table R503.2.1.1(1).

**R803.2.1.1 Exposure durability.** All wood structural panels, when designed to be permanently exposed in outdoor applications, shall be of an exterior exposure durability. Wood structural panel roof sheathing exposed to the underside may be of interior type bonded with exterior glue, identified as Exposure 1.

**R803.2.1.2 Fire-retardant-treated plywood.** The allowable unit stresses for fire-retardant-treated plywood, including fastener values, shall be developed from an *approved* method of investigation that considers the effects of anticipated temperature and humidity to which the fire-retardant-treated plywood will be subjected, the type of treatment and redrying process. The fire-retardant-treated plywood shall be graded by an *approved agency*.

**R803.2.2 Allowable spans.** The maximum allowable spans for wood structural panel roof sheathing shall not exceed the values set forth in Table R503.2.1.1(1), or APA E30.

**R803.2.3 Installation.** Wood structural panel used as roof sheathing shall be installed with joints staggered or not staggered in accordance with Table R602.3(1), or APA E30 for wood roof framing or with Table R804.3 for steel roof framing.

**SECTION R804  
STEEL ROOF FRAMING**

**R804.1 General.** Elements shall be straight and free of any defects that would significantly affect their structural perfor-

mance. Cold-formed steel roof framing members shall comply with the requirements of this section.

**R804.1.1 Applicability limits.** The provisions of this section shall control the construction of cold-formed steel roof framing for buildings not greater than 60 feet (18 288 mm) perpendicular to the joist, rafter or truss span, not greater than 40 feet (12 192 mm) in width parallel to the joist span or truss, less than or equal to three stories above *grade* plane and with roof slopes not less than 3:12 (25-percent slope) or greater than 12:12 (100 percent slope). Cold-formed steel roof framing constructed in accordance with the provisions of this section shall be limited to sites subjected to a maximum design wind speed of 110 miles per hour (49 m/s), Exposure B or C, and a maximum ground snow load of 70 pounds per square foot (3350 Pa).

**R804.1.2 In-line framing.** Cold-formed steel roof framing constructed in accordance with Section R804 shall be located in line with load-bearing studs in accordance with Figure R804.1.2 and the tolerances specified as follows:

1. The maximum tolerance shall be <sup>3</sup>/<sub>4</sub> inch (19.1 mm) between the centerline of the horizontal framing member and the centerline of the vertical framing member.
2. Where the centerline of the horizontal framing member and bearing stiffener are located to one side of the center line of the vertical framing member, the maximum tolerance shall be <sup>1</sup>/<sub>8</sub> inch (3 mm) between the web of the horizontal framing member and the edge of the vertical framing member.

**R804.2 Structural framing.** Load-bearing cold-formed steel roof framing members shall comply with Figure R804.2(1) and with the dimensional and minimum thickness requirements specified in Tables R804.2(1) and R804.2(2). Tracks shall comply with Figure R804.2(2) and shall have a minimum flange width of 1¼ inches (32 mm). The maximum inside bend radius for members shall be the greater of <sup>3</sup>/<sub>32</sub> inch (2.4 mm) minus half the base steel thickness or 1.5 times the base steel thickness.

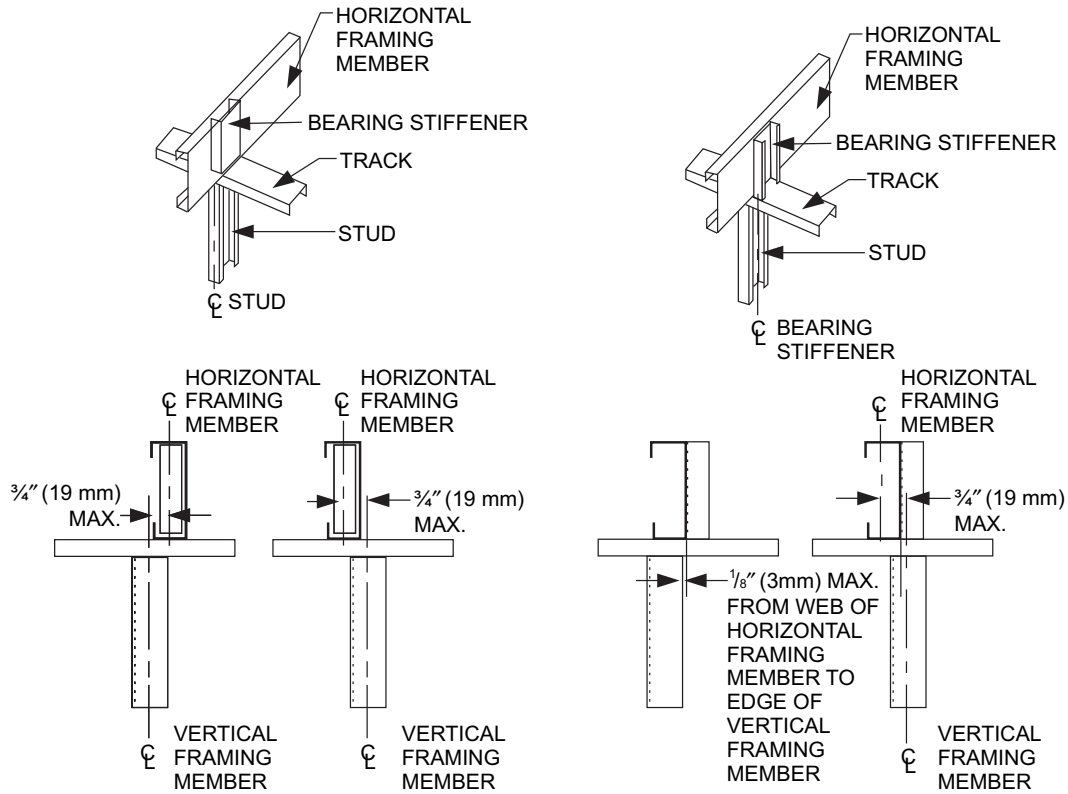
**R804.2.1 Material.** Load-bearing cold-formed steel framing members shall be cold-formed to shape from structural quality sheet steel complying with the requirements of one of the following:

1. ASTM A 653: *Grades* 33 and 50 (Class 1 and 3).
2. ASTM A 792: *Grades* 33 and 50A.
3. ASTM A 1003: Structural *Grades* 33 Type H and 50 Type H.

**R804.2.2 Identification.** Load-bearing cold-formed steel framing members shall have a legible *label*, stencil, stamp or embossment with the following information as a minimum:

1. Manufacturer's identification.
2. Minimum base steel thickness in inches (mm).
3. Minimum coating designation.
4. Minimum yield strength, in kips per square inch (ksi) (MPa).

**ROOF-CEILING CONSTRUCTION**



For SI: 1 inch = 25.4 mm.

**FIGURE R804.1.2  
IN-LINE FRAMING**

**TABLE R804.2(1)  
LOAD-BEARING COLD-FORMED STEEL MEMBER SIZES**

NOMINAL MEMBER SIZE MEMBER DESIGNATION <sup>a</sup>	WEB DEPTH (inches)	MINIMUM FLANGE WIDTH (inches)	MAXIMUM FLANGE WIDTH (inches)	MINIMUM LIP SIZE (inches)
350S162-t	3.5	1.625	2	0.5
550S162-t	5.5	1.625	2	0.5
800S162-t	8	1.625	2	0.5
1000S162-t	10	1.625	2	0.5
1200S162-t	12	1.625	2	0.5

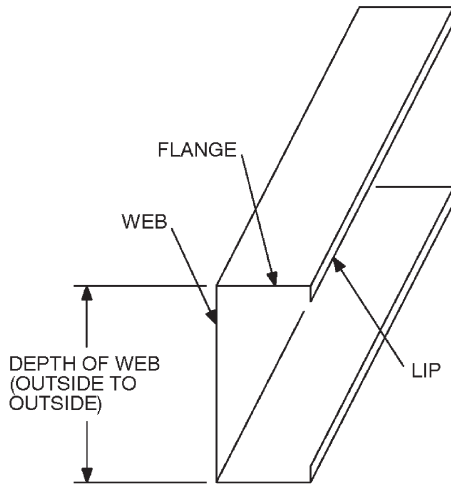
For SI: 1 inch = 25.4 mm.

a. The member designation is defined by the first number representing the member depth in hundredths of an inch, the letter “s” representing a stud or joist member, the second number representing the flange width in hundredths of an inch, and the letter “t” shall be a number representing the minimum base metal thickness in mils [see Table R804.2(2)].

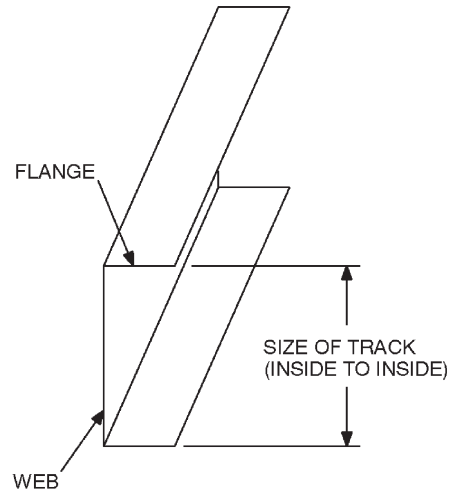
**TABLE R804.2(2)  
MINIMUM THICKNESS OF COLD-FORMED STEEL MEMBERS**

DESIGNATION THICKNESS (mils)	MINIMUM BASE STEEL THICKNESS (inches)
33	0.0329
43	0.0428
54	0.0538
68	0.0677
97	0.0966

For SI: 1 inch = 25.4 mm, 1 mil = 0.0254 mm.



**FIGURE R804.2(1)  
C-SHAPED SECTION**



**FIGURE R804.2(2)  
TRACK SECTION**

**R804.2.3 Corrosion protection.** Load-bearing cold-formed steel framing shall have a metallic coating complying with ASTM A 1003 and one of the following:

1. A minimum of G 60 in accordance with ASTM A 653.
2. A minimum of AZ 50 in accordance with ASTM A 792.

**R804.2.4 Fastening requirements.** Screws for steel-to-steel connections shall be installed with a minimum edge distance and center-to-center spacing of 1/2 inch (13 mm), shall be self-drilling tapping, and shall conform to ASTM C 1513. Structural sheathing shall be attached to cold-formed steel roof rafters with minimum No. 8 self-drilling tapping screws that conform to ASTM C 1513. Screws for attaching structural sheathing to cold-formed steel roof framing shall have a minimum head diameter of 0.292 inch (7.4 mm) with countersunk heads and shall be installed with a minimum edge distance of 3/8 inch (10 mm). Gypsum board ceilings shall be attached to cold-formed steel joists with minimum No. 6 screws conforming to ASTM C 954 or ASTM C 1513 with a bugle head style and shall be installed in accordance with Section R805. For all connections, screws shall extend through the steel a minimum of three exposed threads. All fasteners shall have rust inhibitive coating suitable for the installation in which they are being used, or be manufactured from material not susceptible to corrosion.

Where No. 8 screws are specified in a steel-to-steel connection, reduction of the required number of screws in the connection is permitted in accordance with the reduction factors in Table R804.2.4 when larger screws are used or when one of the sheets of steel being connected is thicker than 33 mils (0.84 mm). When applying the reduction factor, the resulting number of screws shall be rounded up.

**TABLE R804.2.4  
SCREW SUBSTITUTION FACTOR**

SCREW SIZE	THINNEST CONNECTED STEEL SHEET (mils)	
	33	43
#8	1.0	0.67
#10	0.93	0.62
#12	0.86	0.56

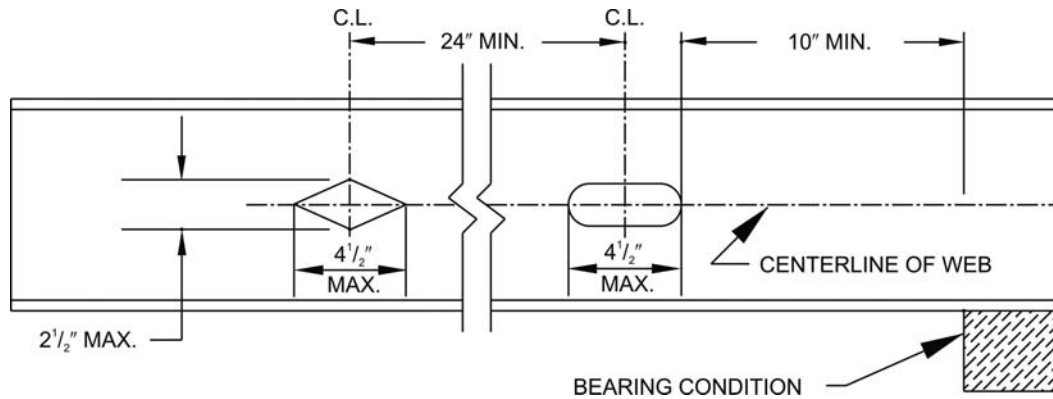
For SI: 1 mil = 0.0254 mm.

**R804.2.5 Web holes, web hole reinforcing and web hole patching.** Web holes, web hole reinforcing, and web hole patching shall be in accordance with this section.

**R804.2.5.1 Web holes.** Web holes in roof framing members shall comply with all of the following conditions:

1. Holes shall conform to Figure R804.2.5.1;
2. Holes shall be permitted only along the centerline of the web of the framing member;
3. Center-to-center spacing of holes shall not be less than 24 inches (610 mm);
4. The web hole width shall not be greater than one-half the member depth, or 2 1/2 inches (64.5 mm);
5. Holes shall have a web hole length not exceeding 4 1/2 inches (114 mm); and
6. The minimum distance between the edge of the bearing surface and the edge of the web hole shall not be less than 10 inches (254 mm).

Framing members with web holes not conforming to the above requirements shall be reinforced in accordance with Section R804.2.5.2, patched in accordance with Section R804.2.5.3 or designed in accordance with accepted engineering practices.



For SI: 1 inch = 25.4 mm.

**FIGURE R804.2.5.1  
WEB HOLES**

**R804.2.5.2 Web hole reinforcing.** Reinforcement of web holes in ceiling joists not conforming to the requirements of Section R804.2.5.1 shall be permitted if the hole is located fully within the center 40 percent of the span and the depth and length of the hole does not exceed 65 percent of the flat width of the web. The reinforcing shall be a steel plate or C-shape section with a hole that does not exceed the web hole size limitations of Section R804.2.5.1 for the member being reinforced. The steel reinforcing shall be the same thickness as the receiving member and shall extend at least 1 inch (25.4 mm) beyond all edges of the hole. The steel reinforcing shall be fastened to the web of the receiving member with No.8 screws spaced no greater than 1 inch (25.4 mm) center-to-center along the edges of the patch with minimum edge distance of 1/2 inch (13 mm).

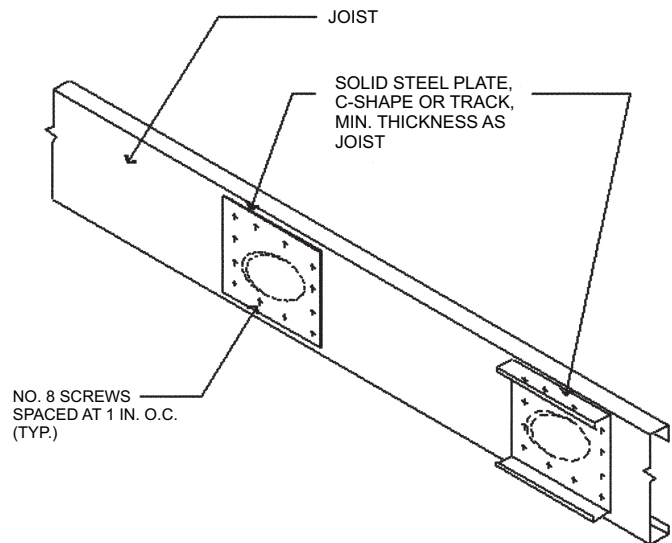
**R804.2.5.3 Hole patching.** Patching of web holes in roof framing members not conforming to the requirements in Section R804.2.5.1 shall be permitted in accordance with either of the following methods:

1. Framing members shall be replaced or designed in accordance with accepted engineering practices where web holes exceed the following size limits:
  - 1.1. The depth of the hole, measured across the web, exceeds 70 percent of the flat width of the web; or
  - 1.2. The length of the hole measured along the web, exceeds 10 inches (254 mm) or the depth of the web, whichever is greater.
2. Web holes not exceeding the dimensional requirements in Section R804.2.5.3, Item 1, shall be patched with a solid steel plate, stud section or track section in accordance with Figure R804.2.5.3. The steel patch shall, as a minimum, be the same thickness as the receiving member and shall extend at least 1 inch (25 mm) beyond

all edges of the hole. The steel patch shall be fastened to the web of the receiving member with No.8 screws spaced no greater than 1 inch (25 mm) center-to-center along the edges of the patch with minimum edge distance of 1/2 inch (13 mm).

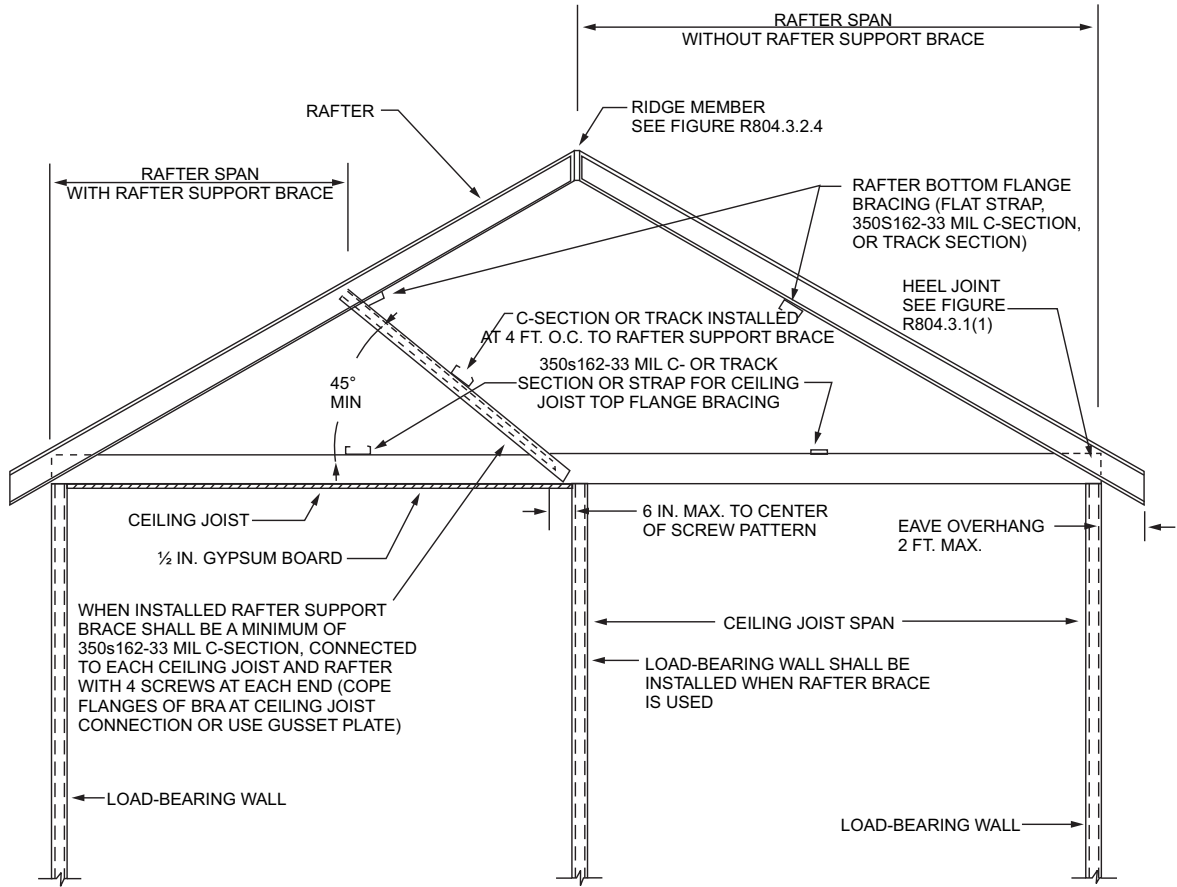
**R804.3 Roof construction.** Cold-formed steel roof systems constructed in accordance with the provisions of this section shall consist of both ceiling joists and rafters in accordance with Figure R804.3 and fastened in accordance with Table R804.3, and hip framing in accordance with Section R804.3.3.

**R804.3.1 Ceiling joists.** Cold-formed steel ceiling joists shall be in accordance with this section.



For SI: 1 inch = 25.4 mm.

**FIGURE R804.2.5.3  
WEB HOLE PATCH**



For SI: 1 inch = 25.4 mm, 1 foot = 304.8 mm, 1 mil = 0.0254 mm.

**FIGURE R804.3**  
**STEEL ROOF CONSTRUCTION**

**TABLE R804.3**  
**ROOF FRAMING FASTENING SCHEDULE<sup>a, b</sup>**

DESCRIPTION OF BUILDING ELEMENTS	NUMBER AND SIZE OF FASTENERS	SPACING OF FASTENERS
Ceiling joist to top track of load-bearing wall	2 No. 10 screws	Each joist
Roof sheathing (oriented strand board or plywood) to rafters	No. 8 screws	6" o.c. on edges and 12" o.c. at interior supports. 6" o.c. at gable end truss
Truss to bearing wall <sup>a</sup>	2 No. 10 screws	Each truss
Gable end truss to endwall top track	No. 10 screws	12" o.c.
Rafter to ceiling joist	Minimum No. 10 screws, per Table R804.3.1.1(9)	Evenly spaced, not less than 1/2" from all edges.

For SI: 1 inch = 25.4 mm, 1 foot = 304.8 mm, 1 pound per square foot = 0.0479 kPa, 1 mil = 0.0254 mm.

- a. Screws shall be applied through the flanges of the truss or ceiling joist or a 54 mil clip angle shall be used with two No. 10 screws in each leg. See Section R804.3.9 for additional requirements to resist uplift forces.
- b. Spacing of fasteners on roof sheathing panel edges applies to panel edges supported by framing members and at all roof plane perimeters. Blocking of roof sheathing panel edges perpendicular to the framing members shall not be required except at the intersection of adjacent roof planes. Roof perimeter shall be supported by framing members or cold-formed blocking of the same depth and gage as the floor members.

**R804.3.1.1 Minimum ceiling joist size.** Ceiling joist size and thickness shall be determined in accordance with the limits set forth in Tables R804.3.1.1(1) through R804.3.1.1(8). When determining the size of ceiling joists, the lateral support of the top flange shall be classified as unbraced, braced at mid-span or braced at third points in accordance with Section R804.3.1.4. Where sheathing material is attached to the top flange of ceiling joists or where the bracing is spaced closer than third point of the joists, the “third point” values from Tables R804.3.1.1(1) through R804.3.1.1(8) shall be used.

Ceiling joists shall have a bearing support length of not less than 1½ inches (38 mm) and shall be connected to roof rafters (heel joint) with No. 10 screws in accordance with Figures R804.3.1.1(1) and R804.3.1.1(2) and Table 804.3.1.1(9).

When continuous joists are framed across interior bearing supports, the interior bearing supports shall be located within 24 inches (610 mm) of midspan of the ceiling joist, and the individual spans shall not exceed the applicable spans in Tables R804.3.1.1(2), R804.3.1.1(4), R804.3.1.1(6) and R804.3.1.1(8).

When the *attic* is to be used as an *occupied space*, the ceiling joists shall be designed in accordance with Section R505.

**R804.3.1.2 Ceiling joist bearing stiffeners.** Where required in Tables R804.3.1.1(1) through R804.3.1.1(8), bearing stiffeners shall be installed at each bearing support in accordance with Figure R804.3.1.1(2). Bearing stiffeners shall be fabricated from a C-shaped or track member in accordance with the one of following:

1. C-shaped bearing stiffeners shall be a minimum 33 mils (0.84 mm) thick.
2. Track bearing stiffener shall be a minimum 43 mils (1.09 mm) thick.

The minimum length of a bearing stiffener shall be the depth of member being stiffened minus ¾ inch (9.5 mm). Each stiffener shall be fastened to the web of the ceiling joist with a minimum of four No. 8 screws equally spaced as shown in Figure R804.3.1.1(2). Installation of stiffeners shall be permitted on either side of the web.

**R804.3.1.3 Ceiling joist bottom flange bracing.** The bottom flanges of ceiling joists shall be laterally braced by the application of gypsum board or continuous steel straps installed perpendicular to the joist run in accordance with one of the following:

1. Gypsum board shall be fastened with No. 6 screws in accordance with Section R702.
2. Steel straps with a minimum size of 1½ inches × 33 mils (38 mm × 0.84 mm) shall be installed at a maximum spacing of 4 feet (1219 mm). Straps shall be fastened to the bottom flange at each joist with one No.8 screw and shall be fastened to blocking with two No.8 screws. Blocking shall be installed between joists at a maximum spacing of 12 feet (3658 mm) measured along a line of contin-

uous strapping (perpendicular to the joist run). Blocking shall also be located at the termination of all straps.

**R804.3.1.4 Ceiling joist top flange bracing.** The top flanges of ceiling joists shall be laterally braced as required by Tables R804.3.1.1(1) through R804.3.1.1(8), in accordance with one of the following:

1. Minimum 33-mil (0.84 mm) C-shaped member in accordance with Figure R804.3.1.4(1).
2. Minimum 33-mil (0.84 mm) track section in accordance with Figure R804.3.1.4(1).
3. Minimum 33-mil (0.84 mm) hat section in accordance with Figure R804.3.1.4(1).
4. Minimum 54-mil (1.37 mm) 1½ inch cold-rolled channel section in accordance with Figure R804.3.1.4(1).
5. Minimum 1½ inch by 33 mil (38 mm by 0.84 mm) continuous steel strap in accordance with Figure R804.3.1.4(2).

Lateral bracing shall be installed perpendicular to the ceiling joists and shall be fastened to the top flange of each joist with one No. 8 screw. Blocking shall be installed between joists in line with bracing at a maximum spacing of 12 feet (3658 mm) measured perpendicular to the joists. Ends of lateral bracing shall be attached to blocking or anchored to a stable building component with two No. 8 screws.

**R804.3.1.5 Ceiling joist splicing.** Splices in ceiling joists shall be permitted, if ceiling joist splices are supported at interior bearing points and are constructed in accordance with Figure R804.3.1.5. The number of screws on each side of the splice shall be the same as required for the heel joint connection in Table R804.3.1.1(9).

**R804.3.2 Roof rafters.** Cold-formed steel roof rafters shall be in accordance with this section.

**R804.3.2.1 Minimum roof rafter sizes.** Roof rafter size and thickness shall be determined in accordance with the limits set forth in Tables R804.3.2.1(1) and R804.3.2.1(2) based on the horizontal projection of the roof rafter span. For determination of roof rafter sizes, reduction of roof spans shall be permitted when a roof rafter support brace is installed in accordance with Section R804.3.2.2. The reduced roof rafter span shall be taken as the larger of the distance from the roof rafter support brace to the ridge or to the heel measured horizontally.

For the purpose of determining roof rafter sizes in Tables R804.3.2.1(1) and R804.3.2.1(2), wind speeds shall be converted to equivalent ground snow loads in accordance with Table R804.3.2.1(3). Roof rafter sizes shall be based on the higher of the ground snow load or the equivalent snow load converted from the wind speed.

**R804.3.2.1.1 Eave overhang.** Eave overhangs shall not exceed 24 inches (610 mm) measured horizontally.



**R804.3.2.1.2 Rake overhangs.** Rake overhangs shall not exceed 12 inches (305 mm) measured horizontally. Outlookers at gable endwalls shall be installed in accordance with Figure R804.3.2.1.2.

**R804.3.2.2 Roof rafter support brace.** When used to reduce roof rafter spans in determining roof rafter sizes, a roof rafter support brace shall meet all of the following conditions:

1. Minimum 350S162-33 C-shaped brace member with maximum length of 8 feet (2438 mm).
2. Minimum brace member slope of 45 degrees (0.785 rad) to the horizontal.
3. Minimum connection of brace to a roof rafter and ceiling joist with four No.10 screws at each end.
4. Maximum 6 inches (152 mm) between brace/ceiling joist connection and load-bearing wall below.
5. Each roof rafter support brace greater than 4 feet (1219 mm) in length, shall be braced with a supplemental brace having a minimum size of 350S162-33 or 350T162-33 such that the maximum unsupported length of the roof rafter support brace is 4 feet (1219 mm). The supplemental brace shall be continuous and shall be connected to each roof rafter support brace using two No.8 screws.

**R804.3.2.3 Roof rafter splice.** Roof rafters shall not be spliced.

**R804.3.2.4 Roof rafter to ceiling joist and ridge member connection.** Roof rafters shall be connected to a parallel ceiling joist to form a continuous tie between exterior walls in accordance with Figures R804.3.1.1(1) or R804.3.1.1(2) and Table R804.3.1.1(9). Ceiling joists shall be connected to the top track of the load-bearing wall in accordance with Table R804.3, either with two No.10 screws applied through the flange of the ceiling joist or by using a 54 mil (1.37 mm) clip angle with two No.10 screws in each leg. Roof rafters shall be connected to a ridge member with a minimum 2-inch by 2-inch (51 mm by 51 mm) clip angle fastened with No. 10 screws to the ridge member in accordance with Figure R804.3.2.4 and Table R804.3.2.4. The clip angle shall have a steel thickness equivalent to or greater than the roof rafter thickness and shall extend the depth of the roof rafter member to the extent possible. The ridge member shall be fabricated from a C-shaped member and a track section, which shall have a minimum size and steel thickness equivalent to or greater than that of adjacent roof rafters and shall be installed in accordance with Figure R804.3.2.4. The ridge member shall extend the full depth of the sloped roof rafter cut.

**R804.3.2.5 Roof rafter bottom flange bracing.** The bottom flanges of roof rafters shall be continuously braced, at a maximum spacing of 8 feet (2440 mm) as

measured parallel to the roof rafters, with one of the following members:

1. Minimum 33-mil (0.84 mm) C-shaped member.
2. Minimum 33-mil (0.84 mm) track section.
3. Minimum 1½-inch by 33-mil (38 mm by 0.84 mm) steel strap.

The bracing element shall be fastened to the bottom flange of each roof rafter with one No.8 screw and shall be fastened to blocking with two No.8 screws. Blocking shall be installed between roof rafters in-line with the continuous bracing at a maximum spacing of 12 feet (3658 mm) measured perpendicular to the roof rafters. The ends of continuous bracing shall be fastened to blocking or anchored to a stable building component with two No.8 screws.

**R804.3.3 Hip framing.** Hip framing shall consist of jack-rafters, hip members, hip support columns and connections in accordance with this section, or shall be in accordance with an *approved* design. The provisions of this section for hip members and hip support columns shall apply only where the jack rafter slope is greater than or equal to the roof slope. For the purposes of determining member sizes in this section, wind speeds shall be converted to equivalent ground snow load in accordance with Table R804.3.2.1(3).

**R804.3.3.1 Jack rafters.** Jack rafters shall meet the requirements for roof rafters in accordance with Section R804.3.2, except that the requirements in Section R804.3.2.4 shall not apply.

**R804.3.3.2 Hip members.** Hip members shall be fabricated from C-shape members and track section, which shall have minimum sizes determined in accordance with Table R804.3.3.2. The C-shape member and track section shall be connected at a maximum spacing of 24 inches (610 mm) using No. 10 screws through top and bottom flanges in accordance with Figure R804.3.2.4. The depth of the hip member shall match that of the roof rafters and jack rafters, or shall be based on an *approved* design for a beam pocket at the corner of the supporting wall.

**R804.3.3.3 Hip support columns.** Hip support columns shall be used to support hip members at the ridge. A hip support column shall consist of a pair of C-shape members, with a minimum size determined in accordance with Table R804.3.3.3. The C-shape members shall be connected at a maximum spacing of 24 inches (610 mm) on center to form a box using minimum 3-inch (76 mm) × 33-mil (0.84 mm) strap connected to each of the flanges of the C-shape members with three-No. 10 screws. Hip support columns shall have a continuous load path to the foundation and shall be supported at the ceiling line by an interior wall or by an *approved* design for a supporting element.

ROOF-CEILING CONSTRUCTION

**TABLE R804.3.1.1(1)**  
**CEILING JOIST SPANS**  
**SINGLE SPANS WITH BEARING STIFFENERS**  
**10 lb per sq ft LIVE LOAD (NO ATTIC STORAGE)<sup>a, b, c</sup> 33 ksi STEEL**

MEMBER DESIGNATION	ALLOWABLE SPAN (feet-inches)					
	Lateral Support of Top (Compression) Flange					
	Unbraced		Mid-Span Bracing		Third-Point Bracing	
	Ceiling Joist Spacing (inches)					
	16	24	16	24	16	24
350S162-33	9'-5"	8'-6"	12'-2"	10'-4"	12'-2"	10'-7"
350S162-43	10'-3"	9'-2"	12'-10"	11'-2"	12'-10"	11'-2"
350S162-54	11'-1"	9'-11"	13'-9"	12'-0"	13'-9"	12'-0"
350S162-68	12'-1"	10'-9"	14'-8"	12'-10"	14'-8"	12'-10"
350S162-97	14'-4"	12'-7"	16'-4"	14'-3"	16'-4"	14'-3"
550S162-33	10'-7"	9'-6"	14'-10"	12'-10"	15'-11"	13'-4"
550S162-43	11'-8"	10'-6"	16'-4"	14'-3"	17'-10"	15'-3"
550S162-54	12'-6"	11'-2"	17'-7"	15'-7"	19'-5"	16'-10"
550S162-68	13'-6"	12'-1"	19'-2"	17'-1"	21'-0"	18'-4"
550S162-97	15'-9"	13'-11"	21'-8"	19'-3"	23'-5"	20'-5"
800S162-33	12'-2"	10'-11"	17'-8"	15'-10"	19'-10"	17'-1"
800S162-43	13'-0"	11'-9"	18'-10"	17'-0"	21'-6"	19'-1"
800S162-54	13'-10"	12'-5"	20'-0"	18'-0"	22'-9"	20'-4"
800S162-68	14'-11"	13'-4"	21'-3"	19'-1"	24'-1"	21'-8"
800S162-97	17'-1"	15'-2"	23'-10"	21'-3"	26'-7"	23'-10"
1000S162-43	13'-11"	12'-6"	20'-2"	18'-3"	23'-1"	20'-9"
1000S162-54	14'-9"	13'-3"	21'-4"	19'-3"	24'-4"	22'-0"
1000S162-68	15'-10"	14'-2"	22'-8"	20'-5"	25'-9"	23'-2"
1000S162-97	18'-0"	16'-0"	25'-3"	22'-7"	28'-3"	25'-4"
1200S162-43	14'-8"	13'-3"	21'-4"	19'-3"	24'-5"	21'-8"
1200S162-54	15'-7"	14'-0"	22'-6"	20'-4"	25'-9"	23'-2"
1200S162-68	16'-8"	14'-11"	23'-11"	21'-6"	27'-2"	24'-6"
1000S162-97	18'-9"	16'-9"	26'-6"	23'-8"	29'-9"	26'-9"

For SI: 1 inch = 25.4 mm, 1 foot = 304.8 mm, 1 pound per square foot = 0.0479 kPa.

a. Deflection criterion:  $L/240$  for total loads.

b. Ceiling dead load = 5 psf.

c. Bearing stiffeners are required at all bearing points and concentrated load locations.

**TABLE R804.3.1.1(2)**  
**CEILING JOIST SPANS**  
**TWO EQUAL SPANS WITH BEARING STIFFENERS**  
**10 lb per sq ft LIVE LOAD (NO ATTIC STORAGE)<sup>a, b, c</sup> 33 ksi STEEL**

MEMBER DESIGNATION	ALLOWABLE SPAN (feet-inches)					
	Lateral Support of Top (Compression) Flange					
	Unbraced		Mid-Span Bracing		Third-Point Bracing	
	Ceiling Joist Spacing (inches)					
	16	24	16	24	16	24
350S162-33	12'-11"	10'-11"	13'-5"	10'-11"	13'-5"	10'-11"
350S162-43	14'-2"	12'-8"	15'-10"	12'-11"	15'-10"	12'-11"
350S162-54	15'-6"	13'-10"	17'-1"	14'-6"	17'-9"	14'-6"
350S162-68	17'-3"	15'-3"	18'-6"	16'-1"	19'-8"	16'-1"
350S162-97	20'-10"	18'-4"	21'-5"	18'-10"	21'-11"	18'-10"
550S162-33	14'-4"	12'-11"	16'-7"	14'-1"	17'-3"	14'-1"
550S162-43	16'-0"	14'-1"	17'-11"	16'-1"	20'-7"	16'-10"
550S162-54	17'-4"	15'-6"	19'-5"	17'-6"	23'-2"	19'-0"
550S162-68	19'-1"	16'-11"	20'-10"	18'-8"	25'-2"	21'-5"
550S162-97	22'-8"	19'-9"	23'-6"	20'-11"	27'-11"	25'-1"
800S162-33	16'-5"	14'-10"	19'-2"	17'-3"	23'-1"	18'-3"
800S162-43	17'-9"	15'-11"	20'-6"	18'-5"	25'-0"	22'-6"
800S162-54	19'-1"	17'-1"	21'-8"	19'-6"	26'-4"	23'-9"
800S162-68	20'-9"	18'-6"	23'-1"	20'-9"	28'-0"	25'-2"
800S162-97	24'-5"	21'-6"	26'-0"	23'-2"	31'-1"	27'-9"
1000S162-43	18'-11"	17'-0"	21'-11"	19'-9"	26'-8"	24'-1"
1000S162-54	20'-3"	18'-2"	23'-2"	20'-10"	28'-2"	25'-5"
1000S162-68	21'-11"	19'-7"	24'-7"	22'-2"	29'-10"	26'-11"
1000S162-97	25'-7"	22'-7"	27'-6"	24'-6"	33'-0"	29'-7"
1200S162-43	19'-11"	17'-11"	23'-1"	20'-10"	28'-3"	25'-6"
1200S162-54	21'-3"	19'-1"	24'-5"	22'-0"	29'-9"	26'-10"
1200S162-68	23'-0"	20'-7"	25'-11"	23'-4"	31'-6"	28'-4"
1000S162-97	26'-7"	23'-6"	28'-9"	25'-10"	34'-8"	31'-1"

For SI: 1 inch = 25.4 mm, 1 foot = 304.8 mm, 1 pound per square foot = 0.0479 kPa.

a. Deflection criterion:  $L/240$  for total loads.

b. Ceiling dead load = 5 psf.

c. Bearing stiffeners are required at all bearing points and concentrated load locations.

**ROOF-CEILING CONSTRUCTION**

**TABLE R804.3.1.1(3)  
CEILING JOIST SPANS  
SINGLE SPANS WITH BEARING STIFFENERS  
20 lb per sq ft LIVE LOAD (LIMITED ATTIC STORAGE)<sup>a, b, c</sup> 33 ksi STEEL**

MEMBER DESIGNATION	ALLOWABLE SPAN (feet-inches)					
	Lateral Support of Top (Compression) Flange					
	Unbraced		Mid-Span Bracing		Third-Point Bracing	
	Ceiling Joist Spacing (inches)					
	16	24	16	24	16	24
350S162-33	8'-2"	7'-2"	9'-9"	8'-1"	9'-11"	8'-1"
350S162-43	8'-10"	7'-10"	11'-0"	9'-5"	11'-0"	9'-7"
350S162-54	9'-6"	8'-6"	11'-9"	10'-3"	11'-9"	10'-3"
350S162-68	10'-4"	9'-2"	12'-7"	11'-0"	12'-7"	11'-0"
350S162-97	12'-1"	10'-8"	14'-0"	12'-0"	14'-0"	12'-0"
550S162-33	9'-2"	8'-3"	12'-2"	10'-2"	12'-6"	10'-5"
550S162-43	10'-1"	9'-1"	13'-7"	11'-7"	14'-5"	12'-2"
550S162-54	10'-9"	9'-8"	14'-10"	12'-10"	15'-11"	13'-6"
550S162-68	11'-7"	10'-4"	16'-4"	14'-0"	17'-5"	14'-11"
550S162-97	13'-4"	11'-10"	18'-5"	16'-2"	20'-1"	17'-1"
800S162-33	10'-7"	9'-6"	15'-1"	13'-0"	16'-2"	13'-7"
800S162-43	11'-4"	10'-2"	16'-5"	14'-6"	18'-2"	15'-9"
800S162-54	12'-0"	10'-9"	17'-4"	15'-6"	19'-6"	17'-0"
800S162-68	12'-10"	11'-6"	18'-5"	16'-6"	20'-10"	18'-3"
800S162-97	14'-7"	12'-11"	20'-5"	18'-3"	22'-11"	20'-5"
1000S162-43	12'-1"	10'-11"	17'-7"	15'-10"	19'-11"	17'-3"
1000S162-54	12'-10"	11'-6"	18'-7"	16'-9"	21'-2"	18'-10"
1000S162-68	13'-8"	12'-3"	19'-8"	17'-8"	22'-4"	20'-1"
1000S162-97	15'-4"	13'-8"	21'-8"	19'-5"	24'-5"	21'-11"
1200S162-43	12'-9"	11'-6"	18'-7"	16'-6"	20'-9"	18'-2"
1200S162-54	13'-6"	12'-2"	19'-7"	17'-8"	22'-5"	20'-2"
1200S162-68	14'-4"	12'-11"	20'-9"	18'-8"	23'-7"	21'-3"
1000S162-97	16'-1"	14'-4"	22'-10"	20'-6"	25'-9"	23'-2"

For SI: 1 inch = 25.4 mm, 1 foot = 304.8 mm, 1 pound per square foot = 0.0479 kPa.

a. Deflection criterion:  $L/240$  for total loads.

b. Ceiling dead load = 5 psf.

c. Bearing stiffeners are required at all bearing points and concentrated load locations.

**TABLE R804.3.1.1(4)  
CEILING JOIST SPANS  
TWO EQUAL SPANS WITH BEARING STIFFENERS  
20 lb per sq ft LIVE LOAD (LIMITED ATTIC STORAGE)<sup>a, b, c</sup> 33 ksi STEEL**

MEMBER DESIGNATION	ALLOWABLE SPAN (feet-inches)					
	Lateral Support of Top (Compression) Flange					
	Unbraced		Mid-Span Bracing		Third-Point Bracing	
	Ceiling Joist Spacing (inches)					
	16	24	16	24	16	24
350S162-33	10'-2"	8'-4"	10'-2"	8'-4"	10'-2"	8'-4"
350S162-43	12'-1"	9'-10"	12'-1"	9'-10"	12'-1"	9'-10"
350S162-54	13'-3"	11'-0"	13'-6"	11'-0"	13'-6"	11'-0"
350S162-68	14'-7"	12'-3"	15'-0"	12'-3"	15'-0"	12'-3"
350S162-97	17'-6"	14'-3"	17'-6"	14'-3"	17'-6"	14'-3"
550S162-33	12'-5"	10'-9"	13'-2"	10'-9"	13'-2"	10'-9"
550S162-43	13'-7"	12'-1"	15'-6"	12'-9"	15'-8"	12'-9"
550S162-54	14'-11"	13'-4"	16'-10"	14'-5"	17'-9"	14'-5"
550S162-68	16'-3"	14'-5"	18'-0"	16'-1"	20'-0"	16'-4"
550S162-97	19'-1"	16'-10"	20'-3"	18'-0"	23'-10"	19'-5"
800S162-33	14'-3"	12'-4"	16'-7"	12'-4"	16'-7"	12'-4"
800S162-43	15'-4"	13'-10"	17'-9"	16'-0"	21'-8"	17'-9"
800S162-54	16'-5"	14'-9"	18'-10"	16'-11"	22'-11"	20'-6"
800S162-68	17'-9"	15'-11"	20'-0"	18'-0"	24'-3"	21'-10"
800S162-97	20'-8"	18'-3"	22'-3"	19'-11"	26'-9"	24'-0"
1000S162-43	16'-5"	14'-9"	19'-0"	17'-2"	23'-3"	18'-11"
1000S162-54	17'-6"	15'-8"	20'-1"	18'-1"	24'-6"	22'-1"
1000S162-68	18'-10"	16'-10"	21'-4"	19'-2"	25'-11"	23'-4"
1000S162-97	21'-8"	19'-3"	23'-7"	21'-2"	28'-5"	25'-6"
1200S162-43	17'-3"	15'-7"	20'-1"	18'-2"	24'-6"	18'-3"
1200S162-54	18'-5"	16'-6"	21'-3"	19'-2"	25'-11"	23'-5"
1200S162-68	19'-9"	17'-8"	22'-6"	20'-3"	27'-4"	24'-8"
1000S162-97	22'-7"	20'-1"	24'-10"	22'-3"	29'-11"	26'-11"

For SI: 1 inch = 25.4 mm, 1 foot = 304.8 mm, 1 pound per square foot = 0.0479 kPa.

a. Deflection criterion:  $L/240$  for total loads.

b. Ceiling dead load = 5 psf.

c. Bearing stiffeners are required at all bearing points and concentrated load locations.

ROOF-CEILING CONSTRUCTION

**TABLE R804.3.1.1(5)  
CEILING JOIST SPANS  
SINGLE SPANS WITHOUT BEARING STIFFENERS  
10 lb per sq ft LIVE LOAD (NO ATTIC STORAGE)<sup>a, b</sup> 33 ksi STEEL**

MEMBER DESIGNATION	ALLOWABLE SPAN (feet-inches)					
	Lateral Support of Top (Compression) Flange					
	Unbraced		Mid-Span Bracing		Third-Point Bracing	
	Ceiling Joist Spacing (inches)					
	16	24	16	24	16	24
350S162-33	9'-5"	8'-6"	12'-2"	10'-4"	12'-2"	10'-7"
350S162-43	10'-3"	9'-12"	13'-2"	11'-6"	13'-2"	11'-6"
350S162-54	11'-1"	9'-11"	13'-9"	12'-0"	13'-9"	12'-0"
350S162-68	12'-1"	10'-9"	14'-8"	12'-10"	14'-8"	12'-10"
350S162-97	14'-4"	12'-7"	16'-10"	14'-3"	16'-4"	14'-3"
550S162-33	10'-7"	9'-6"	14'-10"	12'-10"	15'-11"	13'-4"
550S162-43	11'-8"	10'-6"	16'-4"	14'-3"	17'-10"	15'-3"
550S162-54	12'-6"	11'-2"	17'-7"	15'-7"	19'-5"	16'-10"
550S162-68	13'-6"	12'-1"	19'-2"	17'-0"	21'-0"	18'-4"
550S162-97	15'-9"	13'-11"	21'-8"	19'-3"	23'-5"	20'-5"
800S162-33	—	—	—	—	—	—
800S162-43	13'-0"	11'-9"	18'-10"	17'-0"	21'-6"	19'-0"
800S162-54	13'-10"	12'-5"	20'-0"	18'-0"	22'-9"	20'-4"
800S162-68	14'-11"	13'-4"	21'-3"	19'-1"	24'-1"	21'-8"
800S162-97	17'-1"	15'-2"	23'-10"	21'-3"	26'-7"	23'-10"
1000S162-43	—	—	—	—	—	—
1000S162-54	14'-9"	13'-3"	21'-4"	19'-3"	24'-4"	22'-0"
1000S162-68	15'-10"	14'-2"	22'-8"	20'-5"	25'-9"	23'-2"
1000S162-97	18'-0"	16'-0"	25'-3"	22'-7"	28'-3"	25'-4"
1200S162-43	—	—	—	—	—	—
1200S162-54	—	—	—	—	—	—
1200S162-68	16'-8"	14'-11"	23'-11"	21'-6"	27'-2"	24'-6"
1000S162-97	18'-9"	16'-9"	26'-6"	23'-8"	29'-9"	26'-9"

For SI: 1 inch = 25.4 mm, 1 foot = 304.8 mm, 1 pound per square foot = 0.0479 kPa.

a. Deflection criterion:  $L/240$  for total loads.

b. Ceiling dead load = 5 psf.

**TABLE R804.3.1.1(6)**  
**CEILING JOIST SPANS**  
**TWO EQUAL SPANS WITHOUT BEARING STIFFENERS**  
**10 lb per sq ft LIVE LOAD (NO ATTIC STORAGE)<sup>a, b</sup> 33 ksi STEEL**

MEMBER DESIGNATION	ALLOWABLE SPAN (feet-inches)					
	Lateral Support of Top (Compression) Flange					
	Unbraced		Mid-Span Bracing		Third-Point Bracing	
	Ceiling Joist Spacing (inches)					
	16	24	16	24	16	24
350S162-33	11'-9"	8'-11"	11'-9"	8'-11"	11'-9"	8'-11"
350S162-43	14'-2"	11'-7"	14'-11"	11'-7"	14'-11"	11'-7"
350S162-54	15'-6"	13'-10"	17'-1"	13'-10"	17'-7"	13'-10"
350S162-68	17'-3"	15'-3"	18'-6"	16'-1"	19'-8"	16'-1"
350S162-97	20'-10"	18'-4"	21'-5"	18'-9"	21'-11"	18'-9"
550S162-33	13'-4"	9'-11"	13'-4"	9'-11"	13'-4"	9'-11"
550S162-43	16'-0"	13'-6"	17'-9"	13'-6"	17'-9"	13'-6"
550S162-54	17'-4"	15'-6"	19'-5"	16'-10"	21'-9"	16'-10"
550S162-68	19'-1"	16'-11"	20'-10"	18'-8"	24'-11"	20'-6"
550S162-97	22'-8"	20'-0"	23'-9"	21'-1"	28'-2"	25'-1"
800S162-33	—	—	—	—	—	—
800S162-43	17'-9"	15'-7"	20'-6"	15'-7"	21'-0"	15'-7"
800S162-54	19'-1"	17'-1"	21'-8"	19'-6"	26'-4"	23'-10"
800S162-68	20'-9"	18'-6"	23'-1"	20'-9"	28'-0"	25'-2"
800S162-97	24'-5"	21'-6"	26'-0"	23'-2"	31'-1"	27'-9"
1000S162-43	—	—	—	—	—	—
1000S162-54	20'-3"	18'-2"	23'-2"	20'-10"	28'-2"	21'-2"
1000S162-68	21'-11"	19'-7"	24'-7"	22'-2"	29'-10"	26'-11"
1000S162-97	25'-7"	22'-7"	27'-6"	24'-6"	33'-0"	29'-7"
1200S162-43	—	—	—	—	—	—
1200S162-54	—	—	—	—	—	—
1200S162-68	23'-0"	20'-7"	25'-11"	23'-4"	31'-6"	28'-4"
1000S162-97	26'-7"	23'-6"	28'-9"	25'-10"	34'-8"	31'-1"

For SI: 1 inch = 25.4 mm, 1 foot = 304.8 mm, 1 pound per square foot = 0.0479 kPa.

a. Deflection criterion:  $L/240$  for total loads.

b. Ceiling dead load = 5 psf.

ROOF-CEILING CONSTRUCTION

**TABLE R804.3.1.1(7)  
CEILING JOIST SPANS  
SINGLE SPANS WITHOUT BEARING STIFFENERS  
20 lb per sq ft LIVE LOAD (LIMITED ATTIC STORAGE)<sup>a, b</sup> 33 ksi STEEL**

MEMBER DESIGNATION	ALLOWABLE SPAN (feet-inches)					
	Lateral Support of Top (Compression) Flange					
	Unbraced		Mid-Span Bracing		Third-Point Bracing	
	Ceiling Joist Spacing (inches)					
	16	24	16	24	16	24
350S162-33	8'-2"	6'-10"	9'-9"	6'-10"	9'-11"	6'-10"
350S162-43	8'-10"	7'-10"	11'-0"	9'-5"	11'-0"	9'-7"
350S162-54	9'-6"	8'-6"	11'-9"	10'-3"	11'-9"	10'-3"
350S162-68	10'-4"	9'-2"	12'-7"	11'-0"	12'-7"	11'-0"
350S162-97	12'-10"	10'-8"	13'-9"	12'-0"	13'-9"	12'-0"
550S162-33	9'-2"	8'-3"	12'-2"	8'-5"	12'-6"	8'-5"
550S162-43	10'-1"	9'-1"	13'-7"	11'-8"	14'-5"	12'-2"
550S162-54	10'-9"	9'-8"	14'-10"	12'-10"	15'-11"	13'-6"
550S162-68	11'-7"	10'-4"	16'-4"	14'-0"	17'-5"	14'-11"
550S162-97	13'-4"	11'-10"	18'-5"	16'-2"	20'-1"	17'-4"
800S162-33	—	—	—	—	—	—
800S162-43	11'-4"	10'-1"	16'-5"	13'-6"	18'-1"	13'-6"
800S162-54	20'-0"	10'-9"	17'-4"	15'-6"	19'-6"	27'-0"
800S162-68	12'-10"	11'-6"	18'-5"	16'-6"	20'-10"	18'-3"
800S162-97	14'-7"	12'-11"	20'-5"	18'-3"	22'-11"	20'-5"
1000S162-43	—	—	—	—	—	—
1000S162-54	12'-10"	11'-6"	18'-7"	16'-9"	21'-2"	15'-5"
1000S162-68	13'-8"	12'-3"	19'-8"	17'-8"	22'-4"	20'-1"
1000S162-97	15'-4"	13'-8"	21'-8"	19'-5"	24'-5"	21'-11"
1200S162-43	—	—	—	—	—	—
1200S162-54	—	—	—	—	—	—
1200S162-68	14'-4"	12'-11"	20'-9"	18'-8"	23'-7"	21'-3"
1000S162-97	16'-1"	14'-4"	22'-10"	20'-6"	25'-9"	23'-2"

For SI: 1 inch = 25.4 mm, 1 foot = 304.8 mm, 1 pound per square foot = 0.0479 kPa.

a. Deflection criterion:  $L/240$  for total loads.

b. Ceiling dead load = 5 psf.



**TABLE R804.3.1.1(8)**  
**CEILING JOIST SPANS**  
**TWO EQUAL SPANS WITHOUT BEARING STIFFENERS**  
**20 lb per sq ft LIVE LOAD (LIMITED ATTIC STORAGE)<sup>a, b</sup> 33 ksi STEEL**

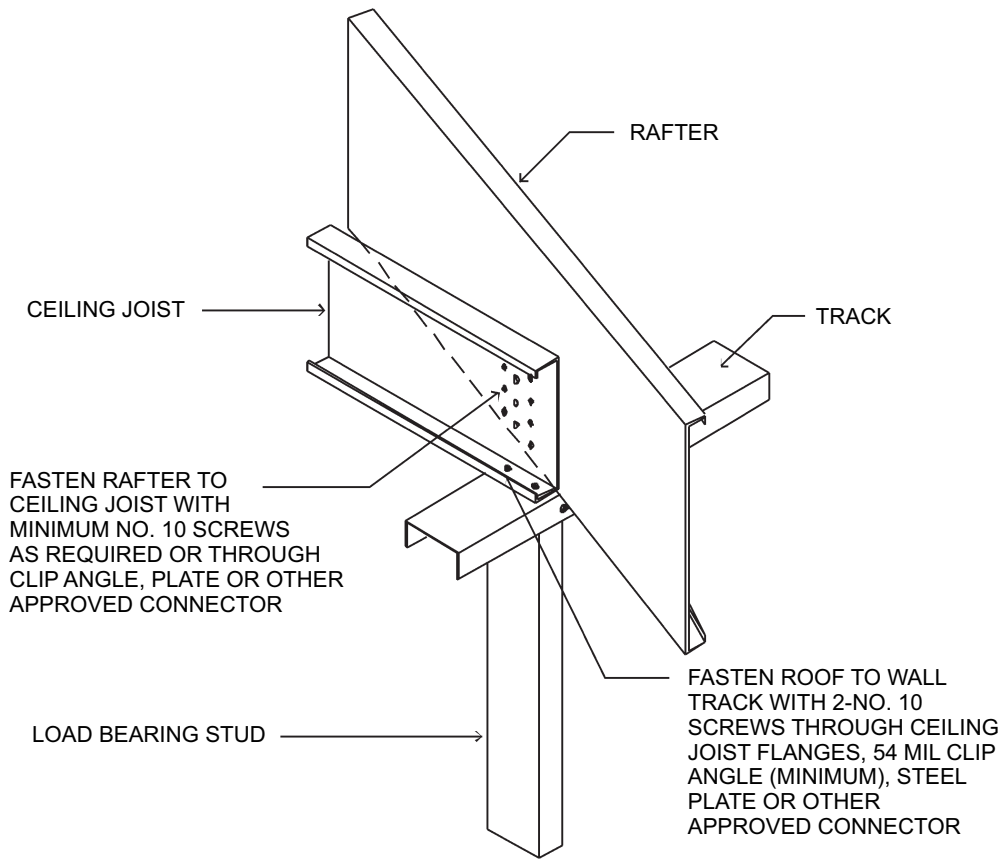
MEMBER DESIGNATION	ALLOWABLE SPAN (feet-inches)					
	Lateral Support of Top (Compression) Flange					
	Unbraced		Mid-Span Bracing		Third-Point Bracing	
	Ceiling Joist Spacing (inches)					
	16	24	16	24	16	24
350S162-33	8'-1"	6'-1"	8'-1"	6'-1"	8'-1"	6'-1"
350S162-43	10'-7"	8'-1"	10'-7"	8'-1"	10'-7"	8'-1"
350S162-54	12'-8"	9'-10"	12'-8"	9'-10"	12'-8"	9'-10"
350S162-68	14'-7"	11'-10"	14'-11"	11'-10"	14'-11"	11'-10"
350S162-97	17'-6"	14'-3"	17'-6"	14'-3"	17'-6"	14'-3"
550S162-33	8'-11"	6'-8"	8'-11"	6'-8"	8'-11"	6'-8"
550S162-43	12'-3"	9'-2"	12'-3"	9'-2"	12'-3"	9'-2"
550S162-54	14'-11"	11'-8"	15'-4"	11'-8"	15'-4"	11'-8"
550S162-68	16'-3"	14'-5"	18'-0"	15'-8"	18'-10"	14'-7"
550S162-97	19'-1"	16'-10"	20'-3"	18'-0"	23'-9"	19'-5"
800S162-33	—	—	—	—	—	—
800S162-43	13'-11"	9'-10"	13'-11"	9'-10"	13'-11"	9'-10"
800S162-54	16'-5"	13'-9"	18'-8"	13'-9"	18'-8"	13'-9"
800S162-68	17'-9"	15'-11"	20'-0"	18'-0"	24'-1"	18'-3"
800S162-97	20'-8"	18'-3"	22'-3"	19'-11"	26'-9"	24'-0"
1000S162-43	—	—	—	—	—	—
1000S162-54	17'-6"	13'-11"	19'-1"	13'-11"	19'-1"	13'-11"
1000S162-68	18'-10"	16'-10"	21'-4"	19'-2"	25'-11"	19'-7"
1000S162-97	21'-8"	19'-3"	23'-7"	21'-2"	28'-5"	25'-6"
1200S162-43	—	—	—	—	—	—
1200S162-54	—	—	—	—	—	—
1200S162-68	19'-9"	17'-8"	22'-6"	19'-8"	26'-8"	19'-8"
1000S162-97	22'-7"	20'-1"	24'-10"	22'-3"	29'-11"	26'-11"

For SI: 1 inch = 25.4 mm, 1 foot = 304.8 mm, 1 pound per square foot = 0.0479 kPa.

a. Deflection criterion:  $L/240$  for total loads.

b. Ceiling dead load = 5 psf.

**ROOF-CEILING CONSTRUCTION**



For SI: 1 mil = 0.0254 mm.

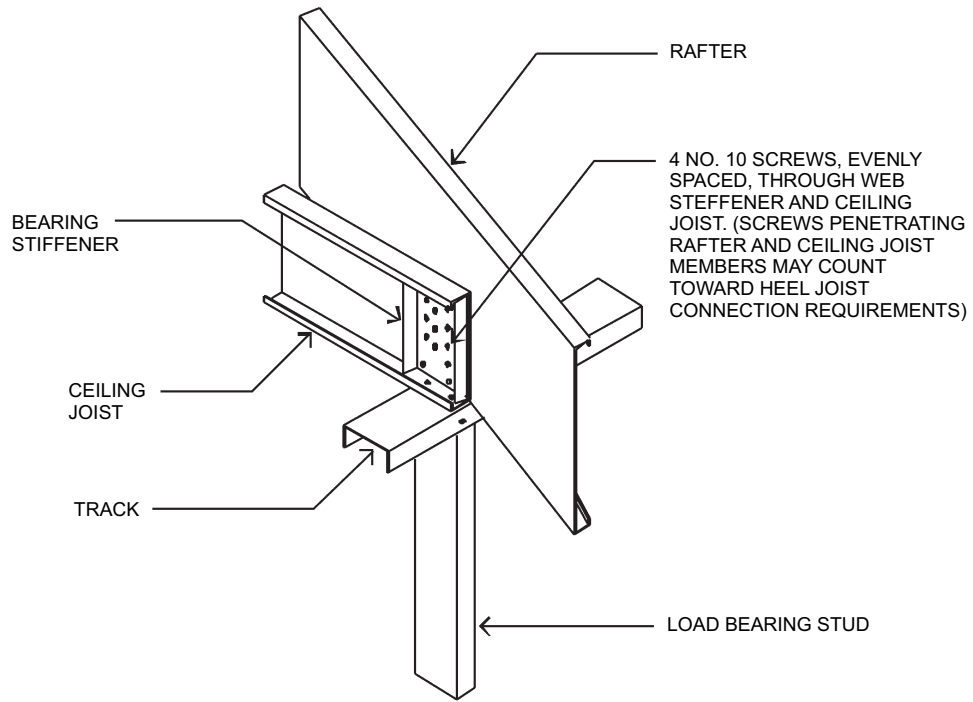
**FIGURE R804.3.1.1(1)  
JOIST TO RAFTER CONNECTION**

**TABLE R804.3.1.1(9)  
NUMBER OF SCREWS REQUIRED FOR CEILING JOIST TO ROOF RAFTER CONNECTION<sup>a</sup>**

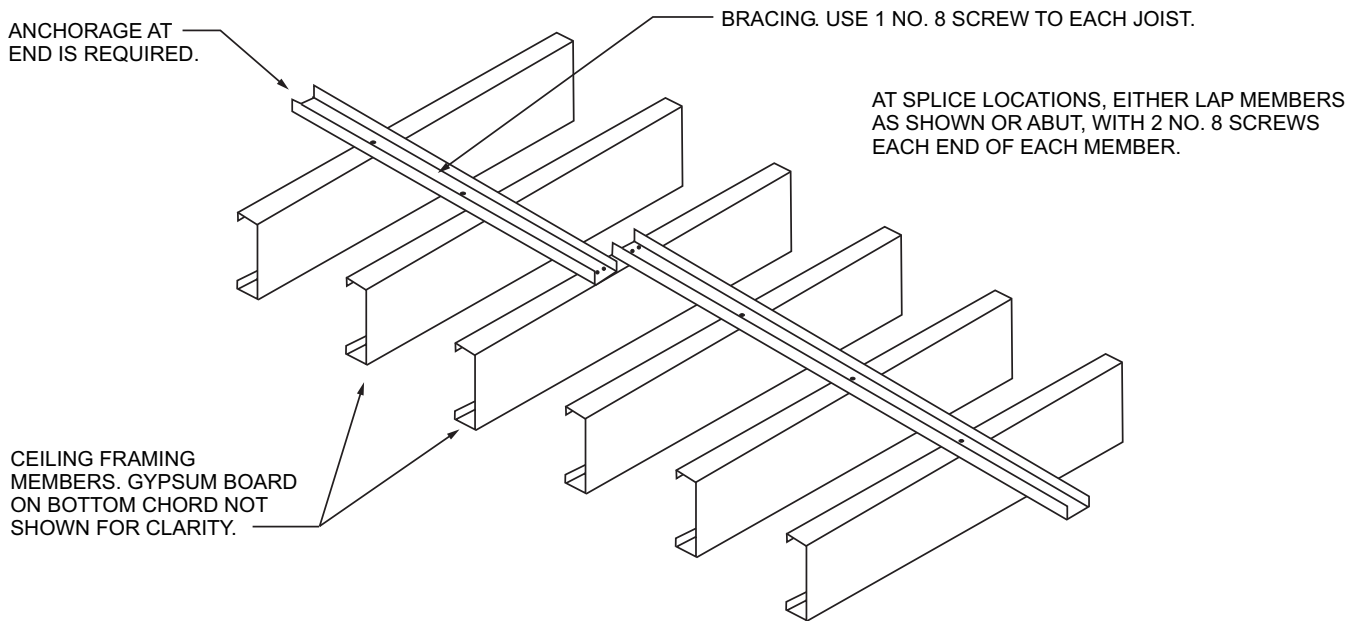
ROOF SLOPE	NUMBER OF SCREWS																			
	Building width (feet)																			
	24				28				32				36				40			
	Ground snow load (psf)																			
	20	30	50	70	20	30	50	70	20	30	50	70	20	30	50	70	20	30	50	70
3/12	5	6	9	11	5	7	10	13	6	8	11	15	7	8	13	17	8	9	14	19
4/12	4	5	7	9	4	5	8	10	5	6	9	12	5	7	10	13	6	7	11	14
5/12	3	4	6	7	4	4	6	8	4	5	7	10	5	5	8	11	5	6	9	12
6/12	3	3	5	6	3	4	6	7	4	4	6	8	4	5	7	9	4	5	8	10
7/12	3	3	4	6	3	3	5	7	3	4	6	7	4	4	6	8	4	5	7	9
8/12	2	3	4	5	3	3	5	6	3	4	5	7	3	4	6	8	4	4	6	8
9/12	2	3	4	5	3	3	4	6	3	3	5	6	3	4	5	7	3	4	6	8
10/12	2	2	4	5	2	3	4	5	3	3	5	6	3	3	5	7	3	4	6	7
11/12	2	2	3	4	2	3	4	5	3	3	4	6	3	3	5	6	3	4	5	7
12/12	2	2	3	4	2	3	4	5	2	3	4	5	3	3	5	6	3	4	5	7

For SI: 1 inch = 25.4 mm, 1 foot = 304.8 mm, 1 pound per square foot = 0.0479 kPa.

a. Screws shall be No. 10.

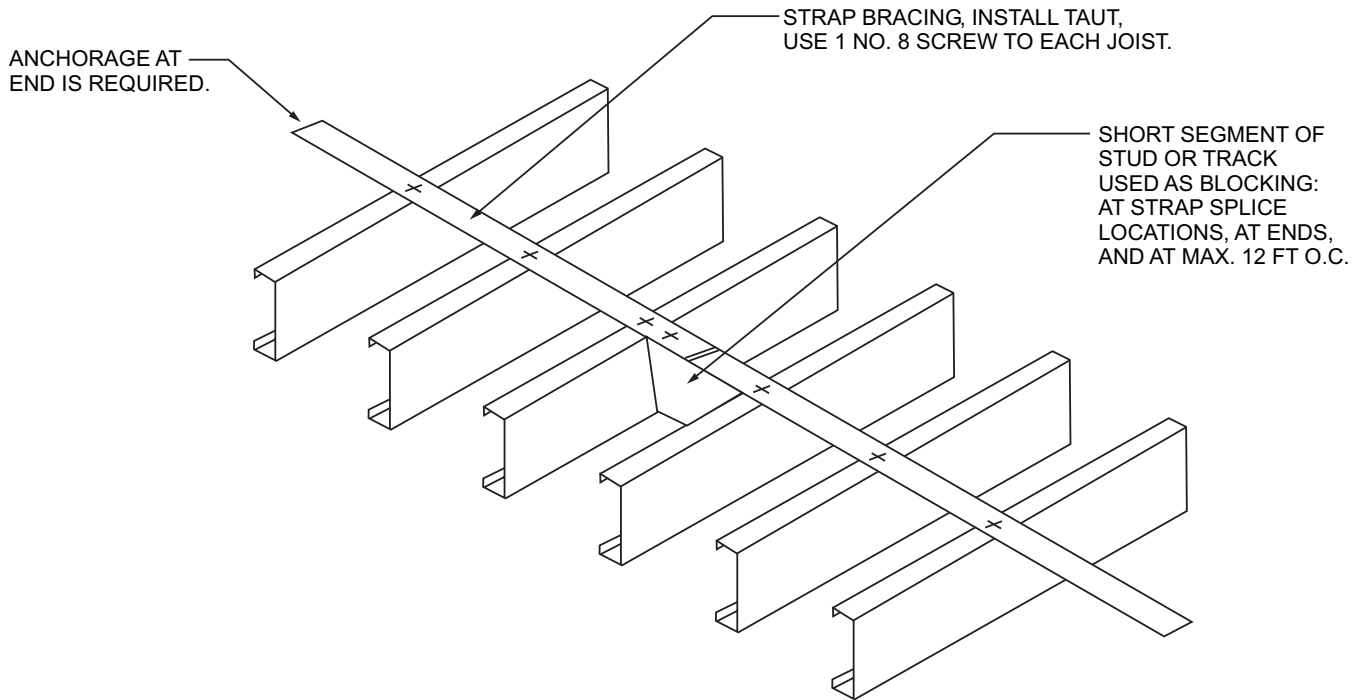


**FIGURE R804.3.1.1(2)  
BEARING STIFFENER**



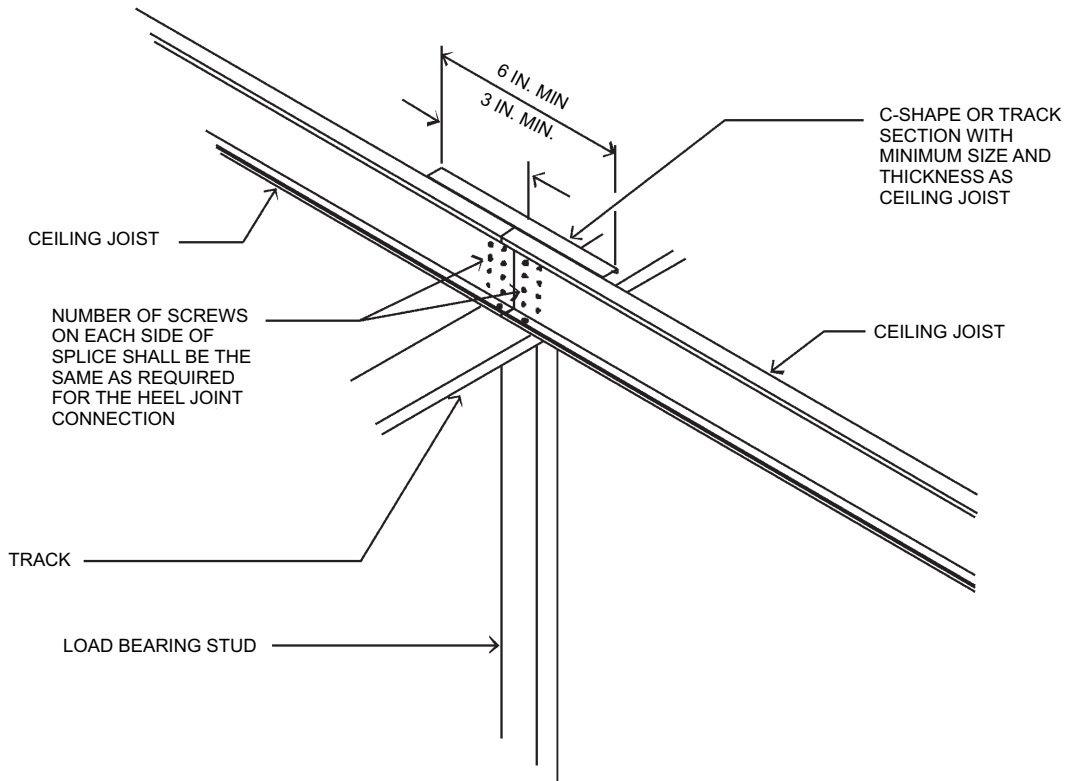
**FIGURE R804.3.1.4(1)  
CEILING JOIST TOP FLANGE BRACING WITH C-SHAPE, TRACK OR COLD-ROLLED CHANNEL**

**ROOF-CEILING CONSTRUCTION**



For SI: 1 foot = 304.8 mm.

**FIGURE R804.3.1.4(2)  
CEILING JOIST TOP FLANGE BRACING WITH CONTINUOUS STEEL STRAP AND BLOCKING**



For SI: 1 inch = 25.4 mm.

**FIGURE R804.3.1.5  
SPLICED CEILING JOISTS**

**TABLE R804.3.2.1(1)**  
**ROOF RAFTER SPANS<sup>a, b, c</sup>**  
**33 ksi STEEL**

MEMBER DESIGNATION	ALLOWABLE SPAN MEASURED HORIZONTALLY (feet-inches)							
	Ground snow load (psf)							
	20		30		50		70	
	Rafter spacing (inches)							
	16	24	16	24	16	24	16	24
550S162-33	14'-0"	11'-6"	11'-11"	9'-7"	9'-6"	7'-9"	8'-2"	6'-8"
550S162-43	16'-8"	13'-11"	14'-5"	11'-9"	11'-6"	9'-5"	9'-10"	8'-0"
550S162-54	17'-11"	15'-7"	15'-7"	13'-3"	12'-11"	10'-7"	11'-1"	9'-1"
550S162-68	19'-2"	16'-9"	16'-9"	14'-7"	14'-1"	11'-10"	12'-6"	10'-2"
550S162-97	21'-3"	18'-6"	18'-6"	16'-2"	15'-8"	13'-8"	14'-0"	12'-2"
800S162-33	16'-5"	13'-5"	13'-11"	11'-4"	11'-1"	8'-2"	9'-0"	6'-0"
800S162-43	19'-9"	16'-1"	16'-8"	13'-7"	13'-4"	10'-10"	11'-5"	9'-4"
800S162-54	22'-8"	18'-6"	19'-2"	15'-8"	15'-4"	12'-6"	13'-1"	10'-8"
800S162-68	25'-10"	21'-2"	21'-11"	17'-10"	17'-6"	14'-4"	15'-0"	12'-3"
800S162-97	21'-3"	18'-6"	18'-6"	16'-2"	15'-8"	13'-8"	14'-0"	12'-2"
1000S162-43	22'-3"	18'-2"	18'-9"	15'-8"	15'-0"	12'-3"	12'-10"	10'-6"
1000S162-54	25'-8"	20'-11"	21'-8"	17'-9"	17'-4"	14'-2"	14'-10"	12'-1"
1000S162-68	29'-7"	24'-2"	25'-0"	20'-5"	20'-0"	16'-4"	17'-2"	14'-0"
1000S162-97	34'-8"	30'-4"	30'-4"	25'-10"	25'-3"	20'-8"	21'-8"	17'-8"
1200S162-54	28'-3"	23'-1"	23'-11"	19'-7"	19'-2"	15'-7"	16'-5"	13'-5"
1200S162-68	32'-10"	26'-10"	27'-9"	22'-8"	22'-2"	18'-1"	19'-0"	15'-6"
1200S162-97	40'-6"	33'-5"	34'-6"	28'-3"	27'-7"	22'-7"	23'-8"	19'-4"

For SI: 1 inch = 25.4 mm, 1 foot = 304.8 mm, 1 pound per square foot = 0.0479 kPa.  
a. Table provides maximum horizontal rafter spans in feet and inches for slopes between 3:12 and 12:12.  
b. Deflection criterion:  $L/240$  for live loads and  $L/180$  for total loads.  
c. Roof dead load = 12 psf.

**ROOF-CEILING CONSTRUCTION**

**TABLE R804.3.2.1(2)  
ROOF RAFTER SPANS<sup>a, b, c</sup>  
50 ksi STEEL**

MEMBER DESIGNATION	ALLOWABLE SPAN MEASURED HORIZONTALLY (feet-inches)							
	Equivalent ground snow load (psf)							
	20		30		50		70	
	Rafter spacing (inches)							
	16	24	16	24	16	24	16	24
550S162-33	15'-4"	12'-11"	13'-4"	10'-11"	10'-9"	8'-9"	9'-2"	7'-6"
550S162-43	16'-8"	14'-7"	14'-7"	12'-9"	12'-3"	10'-6"	11'-0"	9'-0"
550S162-54	17'-11"	15'-7"	15'-7"	13'-8"	13'-2"	11'-6"	11'-9"	10'-3"
550S162-68	19'-2"	16'-9"	16'-9"	14'-7"	14'-1"	12'-4"	12'-7"	11'-0"
550S162-97	21'-3"	18'-6"	18'-6"	16'-2"	15'-8"	13'-8"	14'-0"	12'-3"
800S162-33	18'-10"	15'-5"	15'-11"	12'-9"	12'-3"	8'-2"	9'-0"	6'-0"
800S162-43	22'-3"	18'-2"	18'-10"	15'-5"	15'-1"	12'-3"	12'-11"	10'-6"
800S162-54	24'-2"	21'-2"	21'-1"	18'-5"	17'-10"	14'-8"	15'-5"	12'-7"
800S162-68	25'-11"	22'-8"	22'-8"	19'-9"	19'-1"	16'-8"	17'-1"	14'-9"
800S162-97	28'-10"	25'-2"	25'-2"	22'-0"	21'-2"	18'-6"	19'-0"	16'-7"
1000S162-43	25'-2"	20'-7"	21'-4"	17'-5"	17'-0"	13'-11"	14'-7"	10' - 7"
1000S162-54	29'-0"	24'-6"	25'-4"	20'-9"	20'-3"	16'-7"	17'-5"	14'-2"
1000S162-68	31'-2"	27'-3"	27'-3"	23'-9"	20'-0"	19'-6"	20'-6"	16'-8"
1000S162-97	34'-8"	30'-4"	30'-4"	26'-5"	25'-7"	22'-4"	22'-10"	20'-0"
1200S162-54	33'-2"	27'-1"	28'-1"	22'-11"	22'-5"	18'-4"	19'-3"	15'-8"
1200S162-68	36'- 4"	31'-9"	31'-9"	27'-0"	26'-5"	21'-6"	22'-6"	18'-6"
1200S162-97	40'-6"	35'-4"	35'-4"	30'-11"	29'-10"	26'-1"	26'-8"	23'-1"

For SI: 1 inch = 25.4 mm, 1 foot = 304.8 mm, 1 pound per square foot = 0.0479 kPa.

a. Table provides maximum horizontal rafter spans in feet and inches for slopes between 3:12 and 12:12.

b. Deflection criterion: *L*/240 for live loads and *L*/180 for total loads.

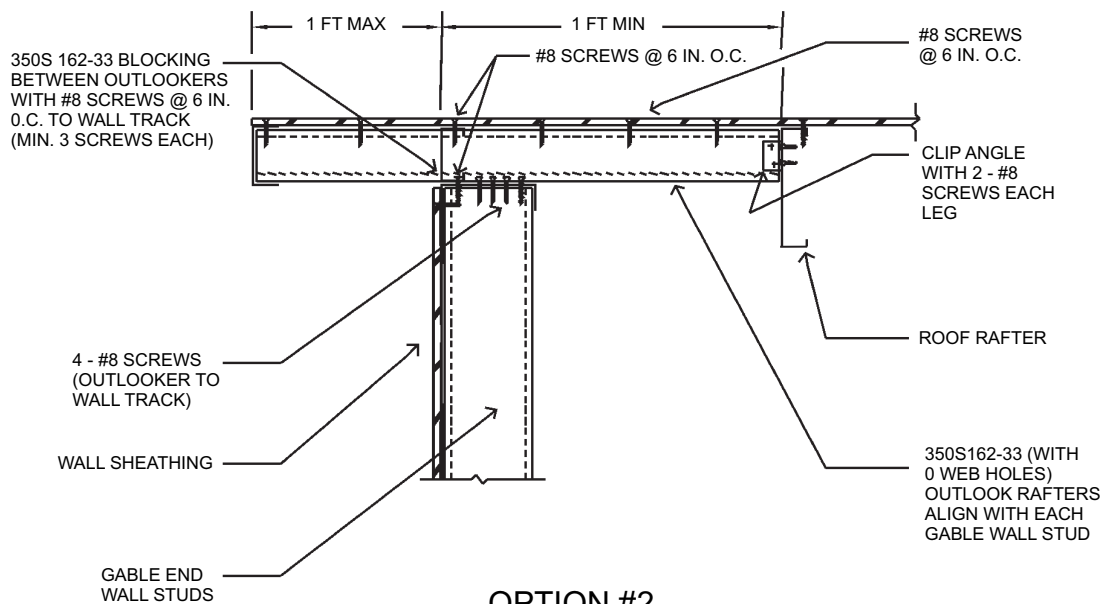
c. Roof dead load = 12 psf.

**TABLE R804.3.2.1(3)**  
**BASIC WIND SPEED TO EQUIVALENT SNOW LOAD CONVERSION**

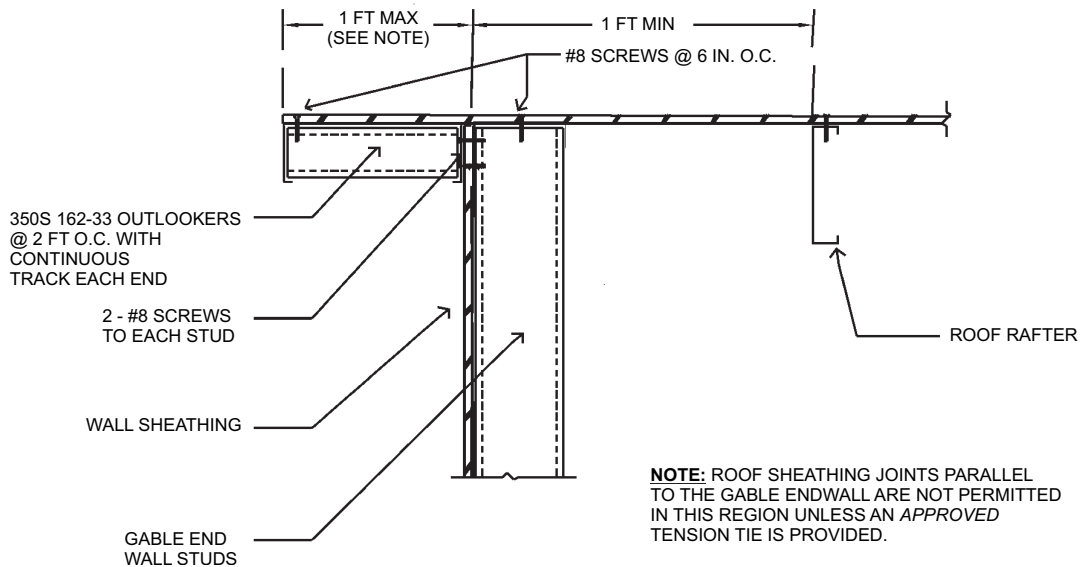
BASIC WIND SPEED AND EXPOSURE		EQUIVALENT GROUND SNOW LOAD (psf)									
		Roof slope									
Exp. B	Exp. C	3:12	4:12	5:12	6:12	7:12	8:12	9:12	10:12	11:12	12:12
85 mph	—	20	20	20	20	20	20	30	30	30	30
100 mph	85 mph	20	20	20	20	30	30	30	30	50	50
110 mph	100 mph	20	20	20	20	30	50	50	50	50	50
—	110 mph	30	30	30	50	50	50	70	70	70	—

For SI: 1 mile per hour = 0.447 m/s, 1 pound per square foot = 0.0479 kPa.

**OPTION #1**



**OPTION #2**



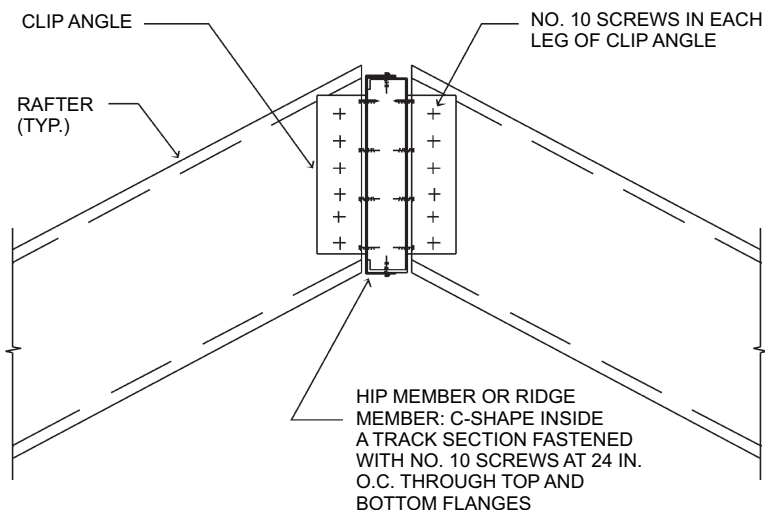
**FIGURE R804.3.2.1.2**  
**GABLE ENDWALL OVERHANG DETAILS**

**TABLE R804.3.2.4**  
**SCREWS REQUIRED AT EACH LEG OF CLIP ANGLE FOR HIP RAFTER**  
**TO HIP MEMBER OR ROOF RAFTER TO RIDGE MEMBER CONNECTION<sup>a</sup>**

BUILDING WIDTH (feet)	NUMBER OF SCREWS			
	Ground snow load (psf)			
	0 to 20	21 to 30	31 to 50	51 to 70
24	2	2	3	4
28	2	3	4	5
32	2	3	4	5
36	3	3	5	6
40	3	4	5	7

For SI: 1 inch = 25.4 mm, 1 foot = 304.8 mm, 1 pound per square foot = 0.0479 kPa.

a. Screws shall be No. 10 minimum.



**FIGURE R804.3.2.4**  
**HIP MEMBER OR RIDGE MEMBER CONNECTION**

**TABLE R804.3.3.2**  
**HIP MEMBER SIZES, 33 ksi STEEL**

BUILDING WIDTH (feet)	HIP MEMBER DESIGNATION <sup>a</sup>			
	Equivalent ground snow load (psf)			
	0 to 20	21 to 30	31 to 50	51 to 70
24	800S162-68	800S162-68	800S162-97	1000S162-97
	800T150-68	800T150-68	800T150-97	1000T150-97
28	1000S162-68	1000S162-68	1000S162-97	1200S162-97
	1000T150-68	1000T150-68	1000T150-97	1200T150-97
32	1000S162-97	1000S162-97	1200S162-97	—
	1000T150-97	1000T150-97	1200T150-97	—
36	1200S162-97	—	—	—
	1200T150-97	—	—	—
40	—	—	—	—

For SI: 1 foot = 304.8 mm, 1 pound per square foot = 0.0479 kPa.

a. The web depth of the roof rafters and jack rafters is to match at the hip or they shall be installed in accordance with an approved design.



**TABLE R804.3.3.3  
HIP SUPPORT COLUMN SIZES**

BUILDING WIDTH (feet)	HIP SUPPORT COLUMN DESIGNATION <sup>a, b</sup>			
	Equivalent ground snow load (psf)			
	0 to 20	21 to 30	31 to 50	51 to 70
24	2-350S162-33	2-350S162-33	2-350S162-43	2-350S162-54
28	2-350S162-54	2-550S162-54	2-550S162-68	2-550S162-68
32	2-550S162-68	2-550S162-68	2-550S162-97	—
36	2-550S162-97	—	—	—
40	—	—	—	—

For SI: 1 foot = 304,8 mm, 1 pound per square foot = 0.0479 kPa.  
a. Box shape column only in accordance with Figure R804.3.3.4(2).  
b. 33 ksi steel for 33 and 43 mil material; 50 ksi steel for thicker material.

**R804.3.3.4 Hip framing connections.** Hip rafter framing connections shall be installed in accordance with the following:

1. Jack rafters shall be connected at the eave to a parallel C-shape blocking member in accordance with Figure R804.3.3.4(1). The C-shape blocking member shall be attached to the supporting wall track with minimum two No. 10 screws.
2. Jack rafters shall be connected to a hip member with a minimum 2 inch × 2 inch (51 mm × 51 mm) clip angle fastened with No. 10 screws to the hip member in accordance with Figure R804.3.2.4 and Table R804.3.2.4. The clip angle shall have a steel thickness equivalent to or greater than the jack rafter thickness and shall extend the depth of the jack rafter member to the extent possible.
3. The connection of the hip support columns at the ceiling line shall be in accordance with Figure R804.3.3.4(2), with an uplift strap sized in accordance with Table R804.3.3.4(1).
4. The connection of hip support members, ridge members and hip support columns at the ridge shall be in accordance with Figures R804.3.3.4(3) and R804.3.3.4(4) and Table R804.3.3.4(2).
5. The connection of hip members to the wall corner shall be in accordance with Figure R804.3.3.4(5) and Table R804.3.3.4(3).

**R804.3.4 Cutting and notching.** Flanges and lips of load-bearing cold-formed steel roof framing members shall not be cut or notched.

**R804.3.5 Headers.** Roof-ceiling framing above wall openings shall be supported on headers. The allowable spans for headers in load-bearing walls shall not exceed the values set forth in Section R603.6 and Tables R603.6(1) through R603.6(24).

**R804.3.6 Framing of openings in roofs and ceilings.** Openings in roofs and ceilings shall be framed with header and trimmer joists. Header joist spans shall not exceed 4 feet (1219 mm) in length. Header and trimmer joists shall be fabricated from joist and track members having a minimum size and thickness at least equivalent to the adjacent ceiling joists or roof rafters and

shall be installed in accordance with Figures R804.3.6(1) and R804.3.6(2). Each header joist shall be connected to trimmer joists with a minimum of four 2-inch by 2-inch (51 by 51 mm) clip angles. Each clip angle shall be fastened to both the header and trimmer joists with four No. 8 screws, evenly spaced, through each leg of the clip angle. The steel thickness of the clip angles shall be not less than that of the ceiling joist or roof rafter. Each track section for a built-up header or trimmer joist shall extend the full length of the joist (continuous).

**R804.3.7 Roof trusses.** Cold-formed steel trusses shall be designed and installed in accordance with AISI S100, Section D4. Trusses shall be connected to the top track of the load-bearing wall in accordance with Table R804.3, either with two No.10 screws applied through the flange of the truss or by using a 54 mil (1.37 mm) clip angle with two No.10 screws in each leg.

**R804.3.8 Ceiling and roof diaphragms.** Ceiling and roof diaphragms shall be in accordance with this section.

**R804.3.8.1 Ceiling diaphragm.** At gable endwalls a ceiling *diaphragm* shall be provided by attaching a minimum 1/2-inch (12.7 mm) gypsum board in accordance with Tables R804.3.8(1) and R804.3.8(2) or a minimum 3/8-inch (9.5 mm) wood structural panel sheathing, which complies with Section R803, in accordance with Table R804.3.8(3) to the bottom of ceiling joists or roof trusses and connected to wall framing in accordance with Figures R804.3.8(1) and R804.3.8(2), unless studs are designed as full height without bracing at the ceiling. Flat blocking shall consist of C-shape or track section with a minimum thickness of 33 mils (0.84 mm).

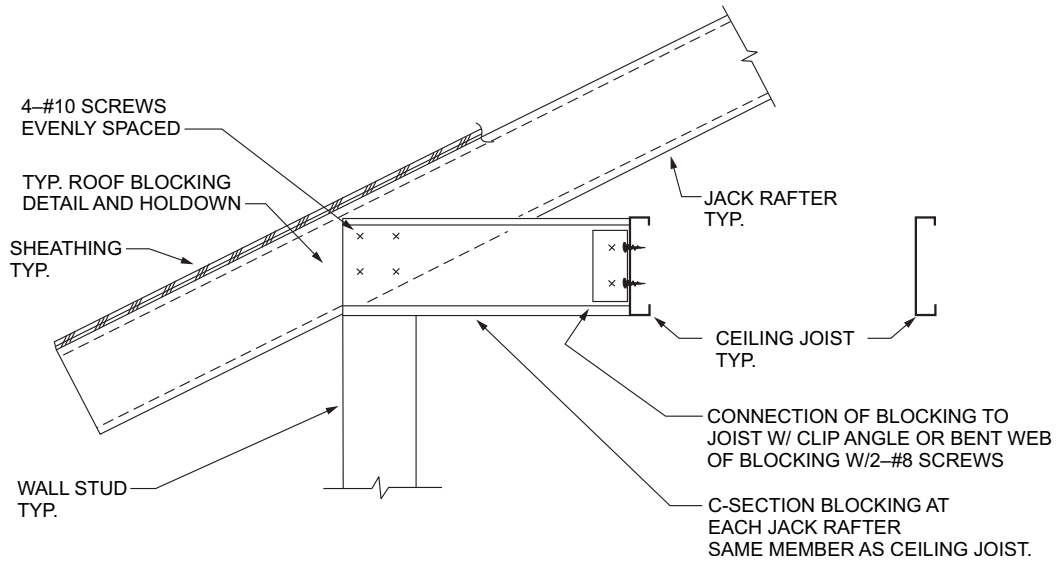
The ceiling *diaphragm* shall be secured with screws spaced at a maximum 6 inches (152 mm) o.c. at panel edges and a maximum 12 inches (305 mm) o.c. in the field. Multiplying the required lengths in Tables R804.3.8(1) and R804.3.8(2) for gypsum board sheathed ceiling diaphragms shall be permitted to be multiplied by 0.35 shall be permitted if all panel edges are blocked. Multiplying the required lengths in Tables R804.3.8(1) and R804.3.8(2) for gypsum board sheathed ceiling diaphragms by 0.9 shall be permitted if all panel edges are secured with screws spaced at 4 inches (102 mm) o.c.

**TABLE R804.3.3.4(1)**  
**UPLIFT STRAP CONNECTION REQUIREMENTS**  
**HIP SUPPORT COLUMN AT CEILING LINE**

BUILDING WIDTH (feet)	BASIC WIND SPEED (mph) EXPOSURE B				
	85	100	110	—	—
	BASIC WIND SPEED (mph) EXPOSURE C				
	—	85	—	100	110
Number of No. 10 screws in each end of each 3 inch by 54-mil steel strap <sup>a, b, c</sup>					
24	3	4	4	6	7
28	4	6	6	8	10
32	5	8	8	11	13
36	7	10	11	14	17
40	—	—	—	—	—

For SI: 1 foot = 304.8 mm, 1 pound per square foot = 0.0479 kPa, 1 mil = 0.0254 mm.

- a. Two straps are required, one each side of the column.
- b. Space screws at 3/4 inch on-center and provide 3/4 inch end distance.
- c. 50 ksi steel strap.



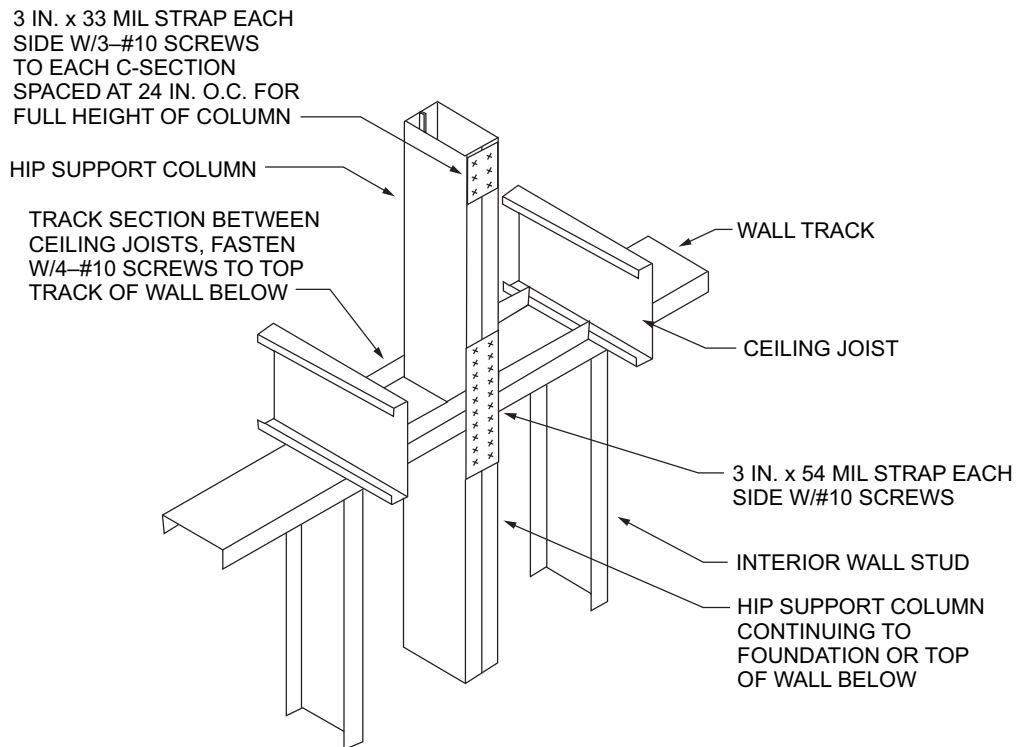
**FIGURE R804.3.3.4(1)**  
**JACK RAFTER CONNECTION AT EAVE**

**TABLE R804.3.3.4(2)  
CONNECTION REQUIREMENTS  
HIP MEMBER TO HIP SUPPORT COLUMN**

BUILDING WIDTH (feet)	NUMBER OF NO. 10 SCREWS IN EACH FRAMING ANGLE <sup>a, b, c</sup>			
	Equivalent ground snow load (psf)			
	0 to 20	21 to 30	31 to 50	51 to 70
24	10	10	10	12
28	10	10	14	18
32	10	12	—	—
36	14	—	—	—
40	—	—	—	—

For SI: 1 foot = 304.8 mm, 1 pound per square foot = 0.0479 kPa.

- a. Screws to be divided equally between the connection to the hip member and the column. Refer to Figures R804.3.3.4(3) and R804.3.3.4(4).
- b. The number of screws required in each framing angle is not to be less than shown in Table R804.3.3.4(1).
- c. 50 ksi steel from the framing angle.



For SI: 1 inch = 25.4 mm, 1 mil = 0.0254 mm.

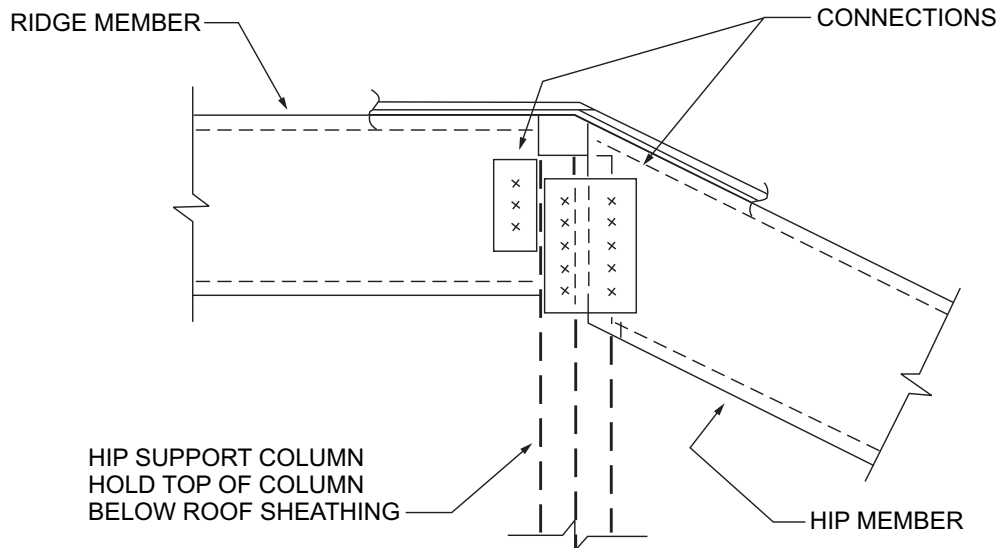
**FIGURE R804.3.3.4(2)  
HIP SUPPORT COLUMN**

**TABLE R804.3.3.4(3)**  
**UPLIFT STRAP CONNECTION REQUIREMENTS**  
**HIP MEMBER TO WALL**

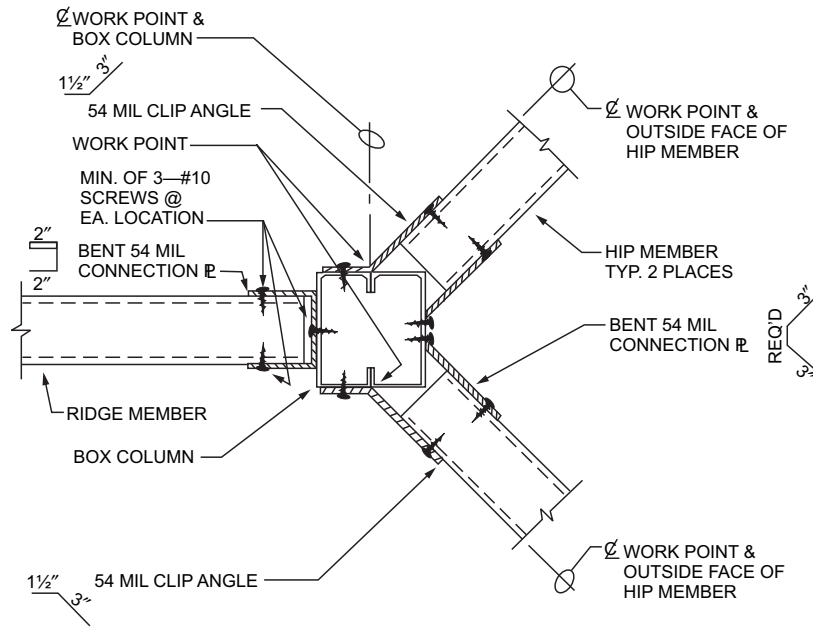
BUILDING WIDTH (feet)	BASIC WIND SPEED (mph) EXPOSURE B				
	85	100	110	—	—
	BASIC WIND SPEED (mph) EXPOSURE C				
	—	85	—	100	110
	Number of No. 10 screws in each end of each 3 inch by 54-mil Steel strap <sup>a, b, c</sup>				
24	2	2	3	3	4
28	2	3	3	4	5
32	3	4	4	6	7
36	3	5	5	7	8
40	—	—	—	—	—

For SI: 1 foot = 304.8 mm, 1 pound per square foot = 0.0479 kPa.

- a. Two straps are required, one each side of the column.
- b. Space screws at  $\frac{3}{4}$  inches on-center and provide  $\frac{3}{4}$  inch end distance.
- c. 50 ksi steel strap.

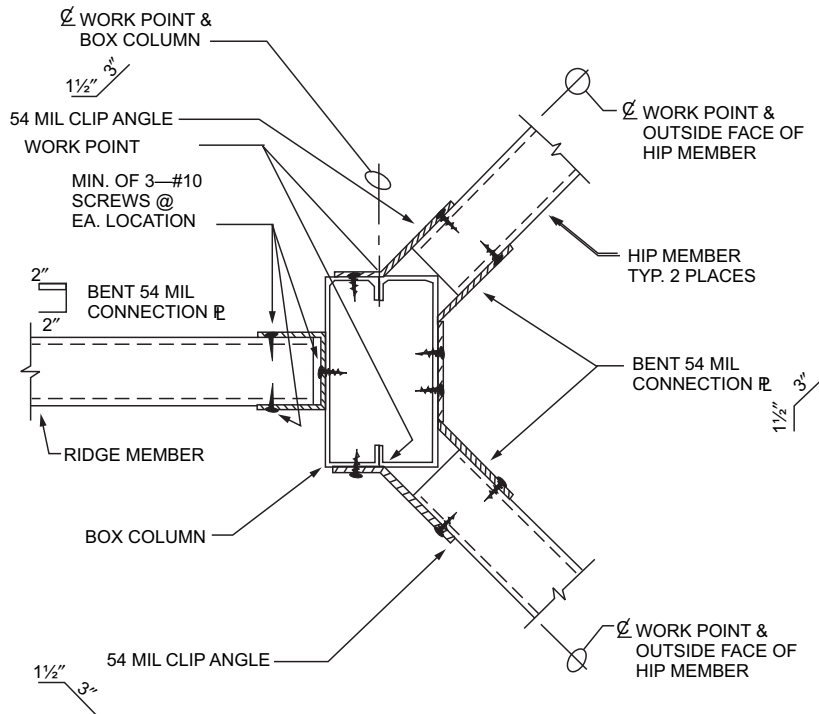


**FIGURE R804.3.3.4(3)**  
**HIP CONNECTIONS AT RIDGE**



NOTE: RAFTERS NOT SHOWN FOR CLARITY

CONNECTION @ 3 1/2" BOX COLUMN

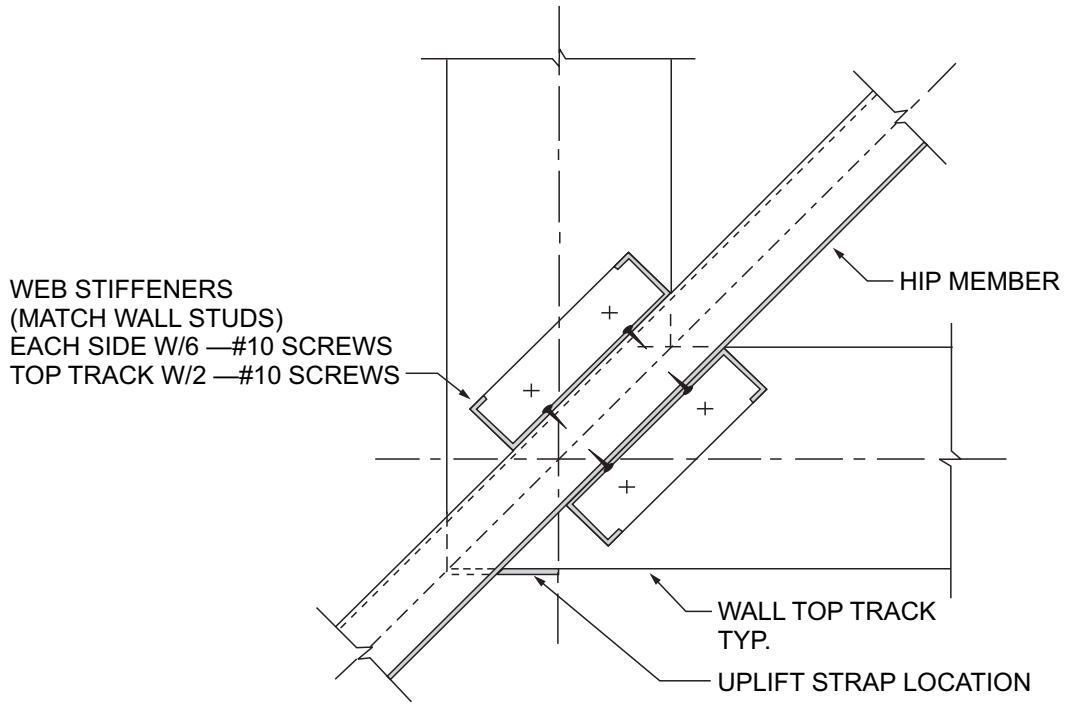


NOTE: RAFTERS NOT SHOWN FOR CLARITY

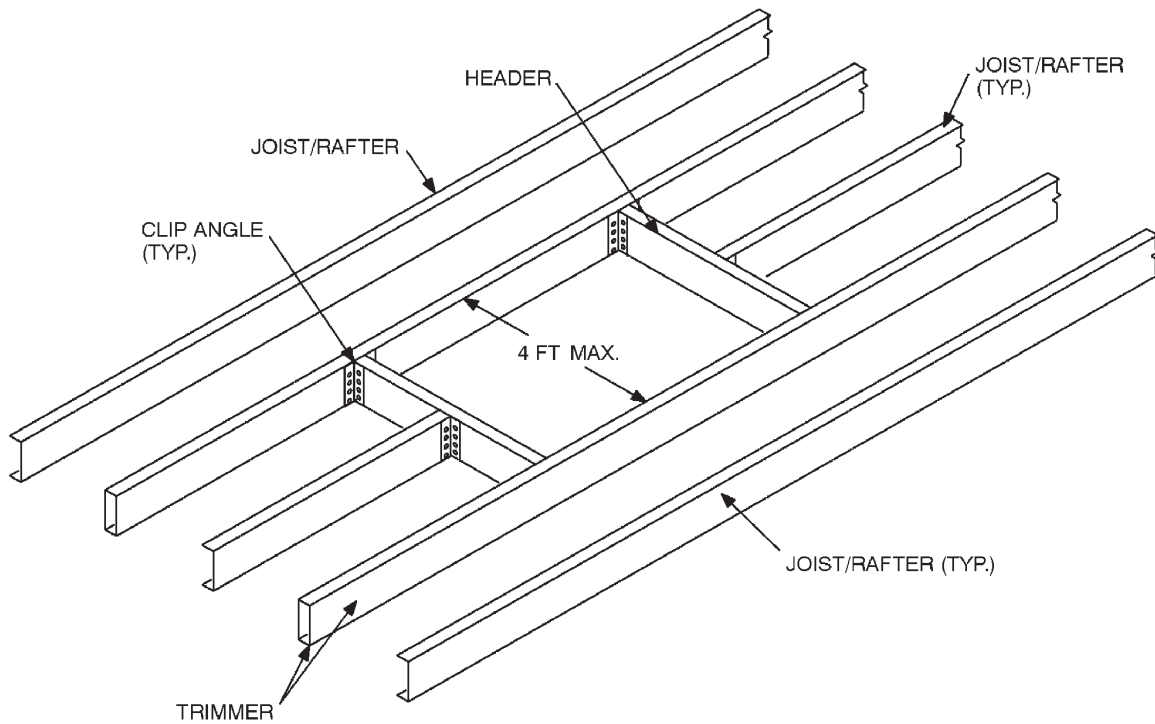
CONNECTION @ 5 1/2" BOX COLUMN

For SI: 1 inch = 25.4 mm, 1 mil = 0.0254 mm.

FIGURE R804.3.3.4(4)  
HIP CONNECTIONS AT RIDGE AND BOX COLUMN

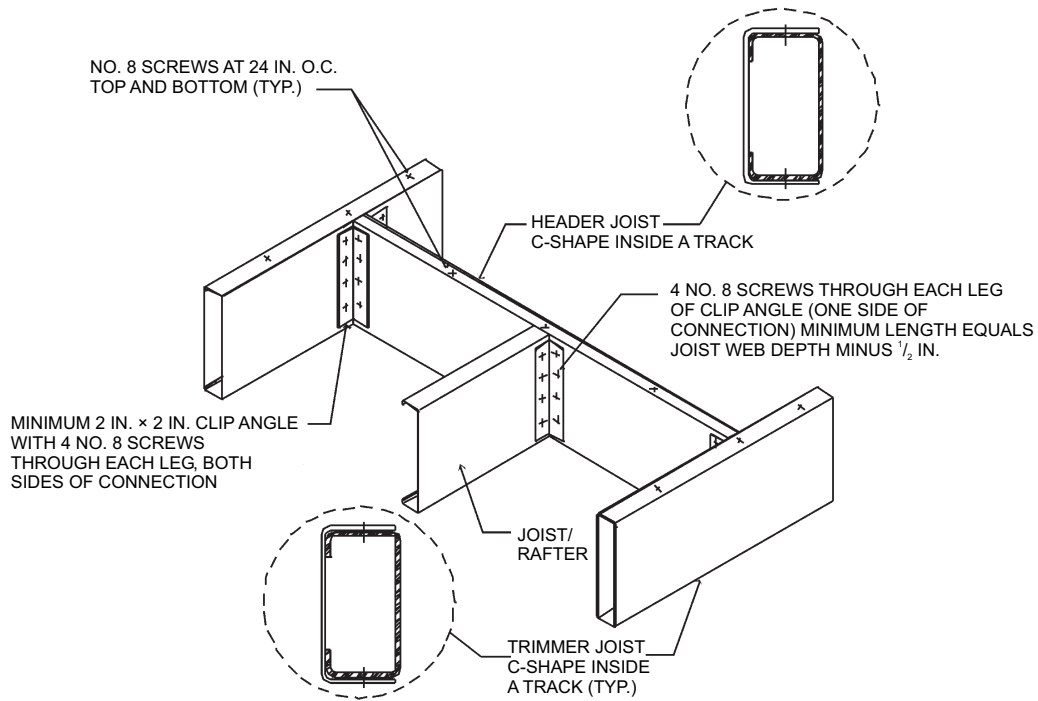


**FIGURE R804.3.3.4(5)**  
**HIP MEMBER CONNECTION AT WALL CORNER**



**FIGURE R804.3.6(1)**  
**ROOF OR CEILING OPENING**

For SI: 1 foot = 304.8 mm.



For SI: 1 inch = 25.4 mm.

**FIGURE R804.3.6(2)  
HEADER TO TRIMMER CONNECTION**

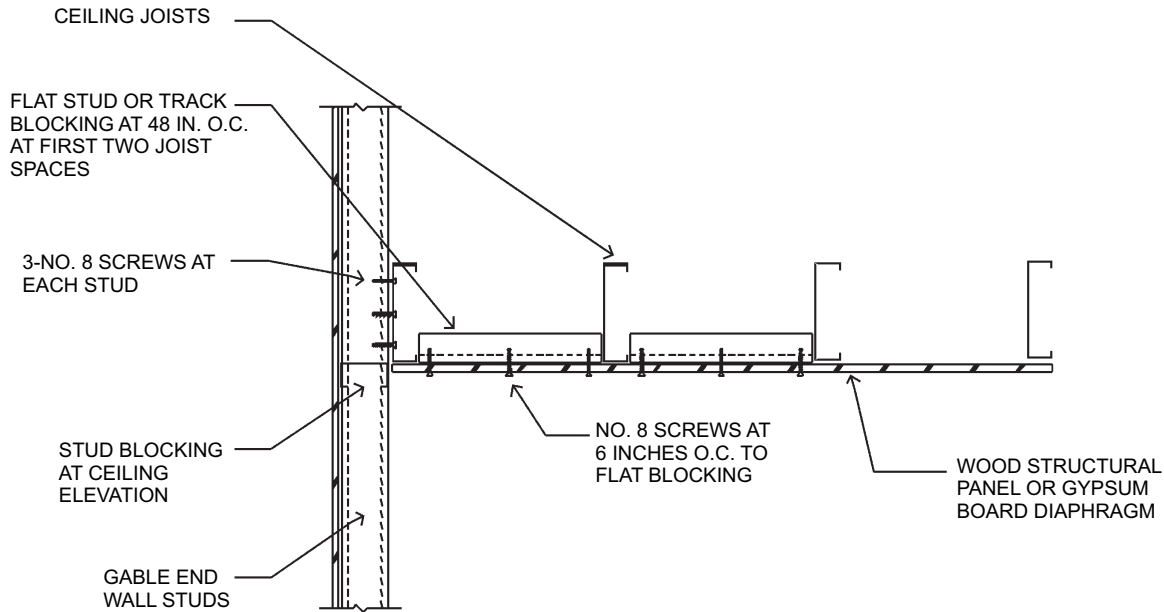
**TABLE R804.3.8(1)  
REQUIRED LENGTHS FOR CEILING DIAPHRAGMS AT GABLE ENDWALLS  
GYPSUM BOARD SHEATHED, CEILING HEIGHT = 8 FT<sup>a, b, c, d, e, f</sup>**

Exposure B		BASIC WIND SPEED (mph)				
		85	100	110	—	—
Exposure C		—	85	—	100	110
Roof pitch	Building endwall width (feet)	Minimum diaphragm length (feet)				
3:12 to 6:12	24 - 28	14	20	22	28	32
	28 - 32	16	22	28	32	38
	32 - 36	20	26	32	38	44
	36 - 40	22	30	36	44	50
6:12 to 9:12	24 - 28	16	22	26	32	36
	28 - 32	20	26	32	38	44
	32 - 36	22	32	38	44	52
	36 - 40	26	36	44	52	60
9:12 to 12:12	24 - 28	18	26	30	36	42
	28 - 32	22	30	36	42	50
	32 - 36	26	36	42	50	60
	36 - 40	30	42	50	60	70

For SI: 1 inch = 25.4 mm, 1 pound per square foot = 0.0479 kPa, 1 mile per hour = 0.447 m/s, 1 foot = 304.8 mm, 1 mil = 0.0254 mm.

- a. Ceiling diaphragm is composed of 1/2 inch gypsum board (min. thickness) secured with screws spaced at 6 inches o.c. at panel edges and 12 inches o.c. in field. Use No. 8 screws (min.) when framing members have a designation thickness of 54 mils or less and No. 10 screws (min.) when framing members have a designation thickness greater than 54 mils.
- b. Maximum aspect ratio (length/width) of diaphragms is 2:1.
- c. Building width is in the direction of horizontal framing members supported by the wall studs.
- d. Required diaphragm lengths are to be provided at each end of the structure.
- e. Multiplying required diaphragm lengths by 0.35 is permitted if all panel edges are blocked.
- f. Multiplying required diaphragm lengths by 0.9 is permitted if all panel edges are secured with screws spaced at 4 inches o.c.

**ROOF-CEILING CONSTRUCTION**



For SI: 1 inch = 25.4 mm.

**FIGURE R804.3.8(1)  
CEILING DIAPHRAGM TO GABLE ENDWALL DETAIL**

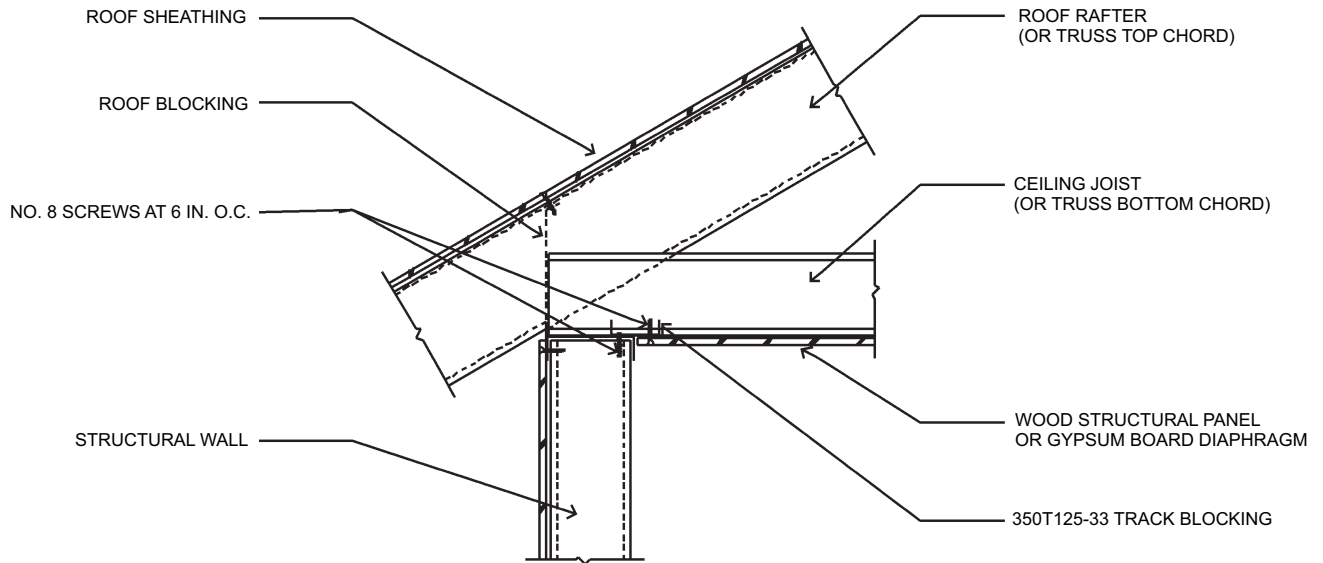
**TABLE R804.3.8(2)  
REQUIRED LENGTHS FOR CEILING DIAPHRAGMS AT GABLE ENDWALLS  
GYPSUM BOARD SHEATHED  
CEILING HEIGHT = 9 OR 10 FT<sup>a, b, c, d, e, f</sup>**

Exposure B		BASIC WIND SPEED (mph)				
		85	100	110	—	—
Exposure C		—	85	—	100	110
Roof pitch	Building endwall width (feet)	Minimum diaphragm length (feet)				
3:12 to 6:12	24 - 28	16	22	26	32	38
	28 - 32	20	26	32	38	44
	32 - 36	22	30	36	44	50
	36 - 40	26	36	42	50	58
6:12 to 9:12	24 - 28	18	26	30	36	42
	28 - 32	22	30	36	42	50
	32 - 36	26	36	42	50	58
	36 - 40	30	42	48	58	68
9:12 to 12:12	24 - 28	20	28	34	40	46
	28 - 32	24	34	40	48	56
	32 - 36	28	40	48	56	66
	36 - 40	34	46	56	66	78

For SI: 1 inch = 25.4 mm, 1 pound per square foot = 0.0479 kPa, 1 mph = 0.447 m/s, 1 foot = 304.8 mm, 1 mil = 0.0254 mm.

- a. Ceiling diaphragm is composed of 1/2 inch gypsum board (min. thickness) secured with screws spaced at 6 inches o.c. at panel edges and 12 inches o.c. in field. Use No. 8 screws (min.) when framing members have a designation thickness of 54 mils or less and No. 10 screws (min.) when framing members have a designation thickness greater than 54 mils.
- b. Maximum aspect ratio (length/width) of diaphragms is 2:1.
- c. Building width is in the direction of horizontal framing members supported by the wall studs.
- d. Required diaphragm lengths are to be provided at each end of the structure.
- e. Required diaphragm lengths are permitted to be multiplied by 0.35 if all panel edges are blocked.
- f. Required diaphragm lengths are permitted to be multiplied by 0.9 if all panel edges are secured with screws spaced at 4 inches o.c.





For SI: 1 inch = 25.4 mm.

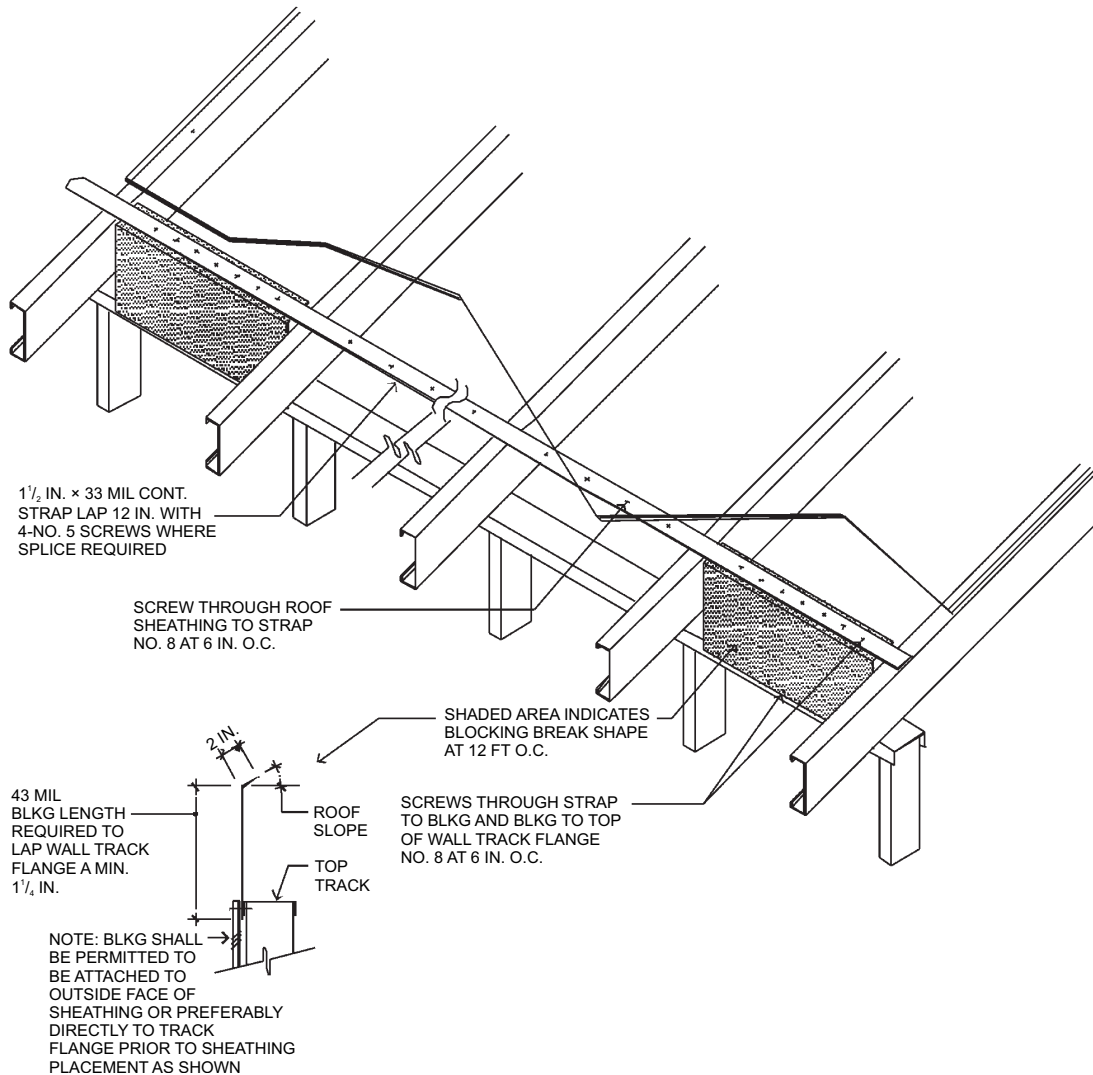
**FIGURE R804.3.8(2)  
CEILING DIAPHRAGM TO SIDEWALL DETAIL**

**TABLE R804.3.8(3)  
REQUIRED LENGTHS FOR CEILING DIAPHRAGMS AT GABLE ENDWALLS  
WOOD STRUCTURAL PANEL SHEATHED  
CEILING HEIGHT = 8, 9 OR 10 FT<sup>a, b, c, d</sup>**

		BASIC WIND SPEED (mph)				
		85	100	110	—	—
Exposure B		85	100	110	—	—
Exposure C		—	85	—	100	110
Roof pitch	Building endwall width (feet)	Minimum diaphragm length (feet)				
3:12 to 6:12	24 - 28	10	10	10	10	10
	28 - 32	12	12	12	12	12
	32 - 36	12	12	12	12	12
	36 - 40	14	14	14	14	14
6:12 to 9:12	24 - 28	10	10	10	10	10
	28 - 32	12	12	12	12	12
	32 - 36	12	12	12	12	12
	36 - 40	14	14	14	14	14
9:12 to 12:12	24 - 28	10	10	10	10	10
	28 - 32	12	12	12	12	12
	32 - 36	12	12	12	12	12
	36 - 40	14	14	14	14	14

For SI: 1 inch = 25.4 mm, 1 pound per square foot = 0.0479 kPa, 1 mile per hour = 0.447 m/s, 1 foot = 304.8 mm, 1 mil = 0.0254 mm.

- a. Ceiling diaphragm is composed of  $\frac{3}{8}$  inch wood structural panel sheathing (min. thickness) secured with screws spaced at 6 inches o.c. at panel edges and in field. Use No. 8 screws (min.) when framing members have a designation thickness of 54 mils or less and No. 10 screws (min.) when framing members have a designation thickness greater than 54 mils.
- b. Maximum aspect ratio (length/width) of diaphragms is 3:1.
- c. Building width is in the direction of horizontal framing members supported by the wall studs.
- d. Required diaphragm lengths are to be provided at each end of the structure.



For SI: 1 mil = 0.0254 mm, 1 inch = 25.4 mm.

**FIGURE R804.3.8(3)**  
**ROOF BLOCKING DETAIL**

**R804.3.8.2 Roof diaphragm.** A roof *diaphragm* shall be provided by attaching a minimum of 3/8 inch (9.5 mm) wood structural panel which complies with Section R803 to roof rafters or truss top chords in accordance with Table R804.3. Buildings with 3:1 or larger plan *aspect ratio* and with roof rafter slope (pitch) of 9:12 or larger shall have the roof rafters and ceiling joists blocked in accordance with Figure R804.3.8(3).

**R804.3.9 Roof tie-down.** Roof assemblies subject to wind uplift pressures of 20 pounds per square foot (0.96 kPa) or greater, as established in Table R301.2(2), shall have rafter-to-bearing wall ties provided in accordance with Table R802.11.

**SECTION R805**  
**CEILING FINISHES**

**R805.1 Ceiling installation.** Ceilings shall be installed in accordance with the requirements for interior wall finishes as provided in Section R702.

**SECTION R806**  
**ROOF VENTILATION**

**R806.1 Ventilation required.** Enclosed *attics* and enclosed rafter spaces formed where ceilings are applied directly to the underside of roof rafters shall have cross ventilation for each separate space by ventilating openings protected against the entrance of rain or snow. Ventilation openings shall have a least dimension of 1/16 inch (1.6 mm) minimum and 1/4 inch (6.4 mm)

maximum. Ventilation openings having a least dimension larger than  $\frac{1}{4}$  inch (6.4 mm) shall be provided with corrosion-resistant wire cloth screening, hardware cloth, or similar material with openings having a least dimension of  $\frac{1}{16}$  inch (1.6 mm) minimum and  $\frac{1}{4}$  inch (6.4 mm) maximum. Openings in roof framing members shall conform to the requirements of Section R802.7.

**R806.2 Minimum area.** The total net free ventilating area shall not be less than  $\frac{1}{150}$  of the area of the space ventilated except that reduction of the total area to  $\frac{1}{300}$  is permitted provided that at least 50 percent and not more than 80 percent of the required ventilating area is provided with vent openings located in the upper portion of the space to be ventilated at least 3 feet (914 mm) above the eave or cornice vents with the balance of the required ventilation provided by eave or cornice vents. As an alternative, the net free cross-ventilation area may be reduced to  $\frac{1}{300}$  when a vapor retarder having a transmission rate not exceeding 1 perm is installed on the warm-in-winter side of the ceiling.

**R806.3 Vent and insulation clearance.** Where eave or cornice vents are installed, insulation shall not block the free flow of air. A minimum of a 1-inch (25 mm) space shall be provided between the insulation and the roof sheathing and at the location of the vent.

**R806.4 Unvented attic assemblies.** Unvented *attic* assemblies (spaces between the ceiling joists of the top *story* and the roof rafters) shall be permitted if all the following conditions are met:

1. The unvented *attic* space is completely contained within the *building thermal envelope*.
2. A minimum insulation level of R-20 air-impermeable or rigid board insulation imbedded into air-impermeable insulation shall be installed above all recessed fixtures, such as recessed lights and exhaust fans.
3. Where wood shingles or shakes are used, a minimum  $\frac{1}{4}$  inch (6 mm) vented air space separates the shingles or shakes and the roofing underlayment above the structural sheathing.
4. *Air-impermeable insulation* shall be a vapor retarder, or shall have a vapor retarder coating or covering in direct contact with the underside of the insulation.
5. Either Items 5.1, 5.2 or 5.3 shall be met, depending on the air permeability of the insulation directly under the structural roof sheathing.
  - 5.1. *Air-impermeable insulation* only. Insulation shall be applied in direct contact with the underside of the structural roof sheathing.
  - 5.2. Air-permeable insulation only. In addition to the air-permeable installed directly below the structural sheathing, rigid board or sheet insulation shall be installed directly above the structural roof sheathing to a minimum insulation level of R-20 for condensation control.

- 5.3. Air-impermeable and air-permeable insulation. The *air-impermeable insulation* shall be applied in direct contact with the underside of the structural roof sheathing to a minimum insulation level of R-20 for condensation control. The air-permeable insulation shall be installed directly under the *air-impermeable insulation*.

## SECTION R807 ATTIC ACCESS

**R807.1 Attic access.** Buildings with combustible ceiling or roof construction shall have an *attic* access opening to *attic* areas that exceed 30 square feet (2.8 m<sup>2</sup>) and have a vertical height of 30 inches (762 mm) or greater. The vertical height shall be measured from the top of the ceiling framing members to the underside of the roof framing members.

The rough-framed opening shall not be less than 22 inches by 30 inches (559 mm by 762 mm) and shall be located in a hallway or other readily accessible location. When located in a wall, the opening shall be a minimum of 22 inches wide by 30 inches high. When the access is located in a ceiling, minimum unobstructed headroom in the *attic* space shall be 30 inches (762 mm) at some point above the access measured vertically from the bottom of ceiling framing members. See Section M1305.1.3 for access requirements where mechanical *equipment* is located in *attics*.

