

Residential Plumbing Chapters 25-33

Refer to the 2011 *Oregon Plumbing Specialty Code*.

Residential Electrical Chapters 34-42

Refer to the 2011 *Oregon Electrical Specialty Code*.

CHAPTER 43
Deleted

||

Part IX—Referenced Standards

CHAPTER 44 REFERENCED STANDARDS

This chapter lists the standards that are referenced in various sections of this document. The standards are listed herein by the promulgating agency of the standard, the standard identification, the effective date and title, and the section or sections of this document that reference the standard. The application of the referenced standards shall be as specified in Section R102.4.

AAMA		American Architectural Manufacturers Association 1827 Walden Office Square, Suite 550 Schaumburg, IL 60173
Standard reference number	Title	Referenced in code section number
AAMA/WDMA/CSA 101/I.S.2/A440—08	North American Fenestration Standards/Specifications for Windows, Doors and Skylights	R308.6.9, R613.6
450—06	Voluntary Performance Rating Method for Muller Fenestration Assemblies	R612.11.1
506—06	Voluntary Specifications for Hurricane Impact and Cycle Testing of Fenestration Products.	R612.9.1
711—07	Voluntary Specification for Self Adhering Flashing Used for Installation of Exterior Wall Fenestration Products.	R703.8

ACI		American Concrete Institute 38800 Country Club Drive Farmington Hills, MI 48331
Standard reference number	Title	Referenced in code section number
318—08	Building Code Requirements for Structural Concrete	R301.2.2.2.4, R301.2.2.3.4, R402.2, R404.1.2, Table R404.1.2(5), Table R404.1.2(6), Table R404.1.2(7), Table R404.1.2(8), Table R404.1.2(9), R404.1.2.1, R404.1.2.3, R404.1.2.4, R404.1.4.2, R404.5.1, R611.1, R611.1.1, R611.1.2, R611.2, R611.5.1, R611.8.2, R611.9.2, R611.9.3
332—08	Code Requirements for Residential Concrete Construction.	R402.2, R403.1, R404.1.2, R404.1.2.4, R404.1.4.2
530—08	Building Code Requirements for Masonry Structures	R404.1.1, R606.1, R606.1.1, R606.12.1, R606.12.2.3.1, R606.12.2.3.2, R606.12.3.1, Table R703.4
530.1—08	Specification for Masonry Structures	R404.1.1, R606.1, R606.1.1, R606.12.1, R606.12.2.3.1, R606.12.2.3.2, R606.12.3.1, Table R703.4

ACCA		Air Conditioning Contractors of America 2800 Shirlington Road, Suite 300 Arlington, VA 22206
Standard reference number	Title	Referenced in code section number
Manual D—95	Residential Duct Systems	M1601.1, M1602.2
Manual J—02	Residential Load Calculation—Eighth Edition.	M1401.3
Manual S—04	Residential Equipment Selection.	M1401.3

REFERENCED STANDARDS

AFPA

American Forest and Paper Association
1111 19th Street, NW, Suite 800
Washington, DC 20036

Standard reference number	Title	Referenced in code section number
NDS—05	National Design Specification (NDS) for Wood Construction—with 2005 Supplement	R404.2.2, R502.2, Table R503.1, R602.3, Table R602.3.1 R611.9.2, R611.9.3, R802.2,
WFCM—01	Wood Frame Construction Manual for One- and Two-family Dwellings	R301.1.1, R301.2.1.1, R602.10.6.2, R611.9.2, R611.9.3, R611.10
AFPA—93	Span Tables for Joists and Rafters	R502.3, R802.4, R802.5
PWF—07	Permanent Wood Foundation Design Specification	R317.3.2, R401.1, R404.2.3

AISI

American Iron and Steel Institute
1140 Connecticut Ave, Suite 705
Washington, DC 20036

Standard reference number	Title	Referenced in code section number
AISI S100—07	North American Specification for the Design of Cold-formed Steel Structural Members	R505.1.3, R603.6, R611.9.2, R611.9.3, R804.3.7
AISI S230—07	Standard for Cold-formed Steel Framing-prescriptive Method for One- and Two-family Dwellings	R301.1.1, R301.2.1.1, R301.2.2.3.1, R301.2.2.3.5, R603.6, R611.9.2, R611.9.3, R611.10

AITC

American Institute of Timber Construction
7012 S. Revere Parkway, Suite 140
Centennial, CO 80112

Standard reference number	Title	Referenced in code section number
ANSI/AITC A 190.1—07	Structural Glued Laminated Timber	R502.1.5, R602.1.2, R802.1.4

ANSI

American National Standards Institute
25 West 43rd Street, Fourth Floor
New York, NY 10036

Standard reference number	Title	Referenced in code section number
A108.1A—99	Installation of Ceramic Tile in the Wet-set Method, with Portland Cement Mortar.	R702.4.1
A108.1B—99	Installation of Ceramic Tile, Quarry Tile on a Cured Portland Cement Mortar Setting Bed with Dry-set or Latex-Portland Mortar	R702.4.1
A108.4—99	Installation of Ceramic Tile with Organic Adhesives or Water Cleanable Tile-setting Epoxy Adhesive.	R702.4.1
A108.5—99	Installation of Ceramic Tile with Dry-set Portland Cement Mortar or Latex-Portland Cement Mortar	R702.4.1
A108.6—99	Installation of Ceramic Tile with Chemical-resistant, Water-cleanable Tile-setting and -grouting Epoxy.	R702.4.1
A108.11—99	Interior Installation of Cementitious Backer Units	R702.4.1
A118.1—99	American National Standard Specifications for Dry-set Portland Cement Mortar.	R702.4.1
A118.3—99	American National Standard Specifications for Chemical-resistant, Water-cleanable Tile-setting and Grouting Epoxy and Water-cleanable Tile-setting Epoxy Adhesive.	R702.4.1
A118.10—99	Specification for Load Bearing, Bonded, Waterproof Membranes for Thin-set Ceramic Tile and Dimension Stone Installation	P2709.2
A136.1—99	American National Standard Specifications for Organic Adhesives for Installation of Ceramic Tile	R702.4.1
A137.1—88	American National Standard Specifications for Ceramic Tile	R702.4.1
A208.1—99	Particleboard	R503.3.1, R605.1
LC1—97	Interior Fuel Gas Piping Systems Using Corrugated Stainless Steel Tubing —with Addenda LC 1a-1999 and LC 1b-2001.	G2414.5.3
LC4—07	Press-connect Copper and Copper Alloy Fittings for use in Fuel Gas Distribution Systems.	G2414.10.2
Z21.1—03	Household Cooking Gas Appliances—with Addenda Z21.1a-2003 and Z21.1b-2003.	G2447.1
Z21.5.1—02	Gas Clothes Dryers—Volume I—Type I Clothes Dryers—with Addenda Z21.5.1a-2003.	G2438.1
Z21.8—94 (R2002)	Installation of Domestic Gas Conversion Burners.	G2443.1

ANSI—continued

Z21.10.1—04	Gas Water Heaters—Volume I—Storage Water Heaters with Input Ratings of 75,000 Btu per hour or Less	G2448.1
Z21.10.3—01	Gas Water Heaters—Volume III—Storage Water Heaters with Input Ratings above 75,000 Btu per hour, Circulating and Instantaneous Water Heaters—with Addenda Z21.10.3a-2003 and Z21.10.3b-2004	G2448.1
Z21.11.2—02	Gas-fired Room Heaters—Volume II—Unvented Room Heaters—with Addenda Z21.11.2a-2003	G2445.1
Z21.13—04	Gas-fired Low-Pressure Steam and Hot Water Boilers	G2452.1
Z21.15—97 (R2003)	Manually Operated Gas Valves for Appliances, Appliance Connector Valves and Hose End Valves—with Addenda Z21.15a-2001 (R2003)	Table G2420.1.1
Z21.22—99 (R2003)	Relief Valves for Hot Water Supply Systems—with Addenda Z21.22a-2000 (R2003) and 21.22b-2001 (R2003)	P2803.2, P2803.7
Z21.24-97	Connectors for Gas Appliances	G2422.1
Z21.40.1—96 (R2002)	Gas-fired, Heat-activated Air Conditioning and Heat Pump Appliances—with Z21.40.1a-97 (R2002)	G2449.1
Z21.40.2—96 (R2002)	Gas-fired, Work-activated Air Conditioning and Heat Pump Appliances (Internal Combustion)—with Z21.40.2a-1997 (R2002)	G2449.1
Z21.42—93 (R2002)	Gas-fired Illuminating Appliances	G2450.1
Z21.47—03	Gas-fired Central Furnaces	G2442.1
Z21.50—03	Vented Gas Fireplaces—with Addenda Z21.50a-2003	G2434.1
Z21.56—01	Gas-fired Pool Heaters—with Addenda Z21.56a-2004 and Z21.56b—2004	G2441.1
Z21.58—95 (R2002)	Outdoor Cooking Gas Appliances—with Addenda Z21.58a-1998 (R2002) and Z21.58b-2002	G2447.1
Z21.60—03	Decorative Gas Appliances for Installation in Solid Fuel Burning Fireplaces—with Addenda Z21.60a-2003	G2432.1
Z21.75/CSA 6.27—01	Connectors for Outdoor Gas Appliances	G2422.1
Z21.80—03	Line Pressure Regulators	G2421.1
Z21.83—98	Fuel Cell Power Plants	M1903.1
Z21.84—02	Manually Listed, Natural Gas Decorative Gas Appliances for Installation in Solid Fuel-burning Fireplaces—with Addenda Z21.84a -2003	G2432.1, G2432.2
Z21.86—04	Gas-fired Vented Space Heating Appliances	G2436.1, G2437.1, G2446.1
Z21.88—02	Vented Gas Fireplace Heaters—with Addenda A21.88a-2003 and Z21.88b—2004	G2435.1
Z21.91—01	Ventless Firebox Enclosures for Gas-fired Unvented Decorative Room Heaters	G2445.7.1
Z83.6—90 (R1998)	Gas-fired Infrared Heaters	G2451.1
Z83.8—02	Gas-fired Unit Heaters and Gas-fired Duct Furnaces—with Addenda Z83.8a-2003	G2444.1
Z97.1—04	Safety Glazing Materials Used in Buildings—Safety Performance Specifications and Methods of Test	R308.1.1, R308.3.1
Z223.1—08	National Fuel-Gas Standard	G2405 (or 4)



APA
 APA—The Engineered Wood Association
 7011 South 19th
 Tacoma, WA 98466

Standard reference number	Title	Referenced in code section number
APA E30—03	Engineered Wood Construction Guide	Table R503.2.1.1(1), R503.2.2, R803.2.2, R803.2.3

APSP
 The Association of Pool & Spa Professionals
 2111 Eisenhower Avenue
 Alexandria, VA 22314

Standard reference number	Title	Referenced in code section number
ANSI/APSP 7—06	Standard for Suction Entrapment Avoidance in Swimming Pools Wading Pools, Spas, Hot Tubs and Catch Basins	AG106.1
ANSI/NSPI 3—99	Standard for Permanently Installed Residential Spas	AG104.1
ANSI/NSPI 4—99	Standard for Above-ground/On-ground Residential Swimming Pools	AG103.2

REFERENCED STANDARDS

APSP—continued

ANSI/NSPI-5—2003	Standard for Residential In-ground Swimming Pools.	AG103.1
ANSI/NSPI 6—99	Standard for Residential Portable Spas	AG104.2

ASCE/SEI
 American Society of Civil Engineers
 Structural Engineering Institute
 1801 Alexander Bell Drive
 Reston, VA 20191

Standard reference number	Title	Referenced in code section number
5—08	Building Code Requirements for Masonry Structures.	R404.1.1, R606.1, R606.1.1, R606.12.1, R606.12.2.3.1, R606.12.2.3.2, R606.12.3.1, Table R703.4
6—08	Specification for Masonry Structures.	R404.1.1, R606.1, R606.1.1, R606.12.1, R606.12.2.3.1, R606.12.2.3.2, R606.12.3.1, Table R703.4
7—05	Minimum Design Loads for Buildings and Other Structures.	R301.2.1.1, R301.2.1.2, R301.2.1.5, R301.2.1.5.1, R301.2.4.1, Table R611.6(1), Table R611.6(2), Table R611.6(3), Table R611.6(4), Table R611.7(1A), R611.9.2, R611.9.3, Table R802.11, AH107.4.3
24—05	Flood-resistant Design and Construction	R301.2.4, R301.2.4.1, R322.1, R322.1.1, R322.1.6, R322.1.9, R322.2.2, AG103.3
32—01	Design and Construction of Frost-protected Shallow Foundations	R403.1.4.1

ASHRAE
 American Society of Heating, Refrigerating and Air-Conditioning Engineers, Inc.
 1791 Tullie Circle, NE
 Atlanta, GA 30329

Standard reference number	Title	Referenced in code section number
34—2004	Designation and Safety Classification of Refrigerants	M1411.1
> ASHRAE—2005	ASHRAE Fundamentals Handbook—2005.	N1103.1, P3001.2, P3101.4, P3103.2

ASME
 American Society of Mechanical Engineers
 Three Park Avenue
 New York, NY 10016-5990

Standard reference number	Title	Referenced in code section number
A17.1/CSA B44—2007	Safety Code for Elevators and Escalators.	R321.1
A18.1—2005	Safety Standard for Platforms and Stairway Chair Lifts	R321.2
> B1.20.1—1983 (R2006)	Pipe Threads, General Purpose (Inch)	G2414.9
> B16.33—2002 (R2006)	Manually Operated Metallic Gas Valves for Use in Gas Piping Systems up to 125 psig (Sizes 1/2 through 2).	Table G2420.1.1
B16.44—02	Manually Operated Metallic Gas Valves For Use in Above-ground Piping Systems up to 5 psi.	Table G2420.1.1
B36.10M—2004	Welded and Seamless Wrought-steel Pipe	G2414.4.2
BPVC—2004	ASME Boiler and Pressure Vessel Code	G2452.1, M2001.1.1
> CSD-1—2004	Controls and Safety Devices for Automatically Fired Boilers.	G2452.1, M2001.1.1



ASTM International
100 Barr Harbor Drive
West Conshohocken, PA 19428

Standard reference number	Title	Referenced in code section number
A 36/A 36M—05	Specification for Carbon Structural Steel	R606.15, R611.5.2.2
A 53/A 53M—06a	Specification for Pipe, Steel, Black and Hot-dipped, Zinc-coated Welded and Seamless	G2414.4.2, Table M2101.1
A 82/A 82M—05a	Specification for Steel Wire, Plain, for Concrete Reinforcement	R606.15
A 106/A 106M—06a	Specification for Seamless Carbon Steel Pipe for High Temperature Service.	G2414.4.2, Table M2101.1
A 153/A 153M—05	Specification for Zinc Coating (Hot Dip) on Iron and Steel Hardware.	R317.3, Table R606.15.1
A 167—99(2004)	Specification for Stainless and Heat-resisting Chromium-nickel Steel Plate, Sheet and Strip	R606.15, Table R606.15.1
A 240/A 240M—07	Standard Specification for Chromium and Chromium-nickel Stainless Steel Plate, Sheet and Strip for Pressure Vessels and for General Applications	Table R905.10.3(1)
A 254—97(2002)	Specification for Copper Brazed Steel Tubing	G2414.5.1, Table M2101.1
A 307—04e01	Specification for Carbon Steel Bolts and Studs, 6000 psi Tensile Strength.	R611.5.2.2
A 463/A 463M—05	Standard Specification for Steel Sheet, Aluminum-coated by the Hot-dip Process.	Table R905.10.3(2)
A 510—06	Specification for General Requirements for Wire Rods and Coarse Round Wire, Carbon Steel	R606.15
A 539—99	Specification for Electric-resistance-welded Coiled Steel Tubing for Gas and Fuel Oil Lines	M2202.1
A 615/A 615M—04a	Specification for Deformed and Plain Billet-steel Bars for Concrete Reinforcement	R402.3.1, R404.1.2.3.7.1, R611.5.2.1
A 641/A 641M—03	Specification for Zinc-coated (Galvanized) Carbon Steel Wire	Table R606.15.1
A 653/A 653M—07	Specification for Steel Sheet, Zinc-coated (Galvanized) or Zinc-iron Alloy-coated (Galvanized) by the Hot-dip Process	M1601.1.1, R317.3.1, R505.2.1, R505.2.3, R603.2.1, R603.2.3, Table R606.15.1, R611.5.2.3, R804.2.1, R804.2.3, Table R905.10.3(1), Table R905.10.3(2)
A 706/A 706M—05a	Specification for Low-alloy Steel Deformed and Plain Bars for Concrete Reinforcement.	R402.3.1, R404.1.2.3.7.1, R611.5.2.1
A 755/A 755M—07	Specification for Steel Sheet, Metallic Coated by the Hot-dip Process and Prepainted by the Coil-coating Process for Exterior Exposed Building Products	Table R905.10.3(2)
A 792/A 792M—06a	Specification for Steel Sheet, 55% Aluminum-zinc Alloy-coated by the Hot-dip Process	R505.2.1, R505.2.3, R603.2.1, R603.2.3, R611.5.2.3, R804.2.1, R804.2.3, Table 905.10.3 (2)
A 875/A 875M—06	Specification for Steel Sheet, Zinc-5%, Aluminum Alloy-coated by the Hot-dip Process	R611.5.3.2, Table R905.10.3 (2)
A 924/A 924M—07	Standard Specification for General Requirements for Steel Sheet, Metallic-coated by the Hot-Dip Process.	Table R905.10.3(1)
A 951—06	Specification for Steel Wire Masonry Joint Reinforcement.	R606.15
A 996/A 996M—06a	Specifications for Rail-steel and Axel-steel Deformed Bars for Concrete Reinforcement	R404.1.2.3.7, R404.1.2.3.7.1, R611.5.2.1, Table R611.5.4(2)
A 1003/A 1003M—05	Standard Specification for Steel Sheet, Carbon, Metallic and Nonmetallic-coated for Cold-formed Framing Members	R505.2.1, R505.2.3, R603.2.1, R603.2.3, R804.2.1, R804.2.3
B 42—02e01	Specification for Seamless Copper Pipe, Standard Sizes	Table M2101.1
B 43—98 (2004)	Specification for Seamless Red Brass Pipe, Standard Sizes.	G2413.5.2, Table M2101.1
B 75—02	Specification for Seamless Copper Tube.	Table M2101.1
B 88—03	Specification for Seamless Copper Water Tube	G2414.5.2, Table M2101.1
B 101—02	Specification for Lead-coated Copper Sheet and Strip for Building Construction.	Table R905.2.8.2, Table R905.10.3(1)
B 135—02	Specification for Seamless Brass Tube	Table M2101.1
B 209—06	Specification for Aluminum and Aluminum-alloy Sheet and Plate	Table 905.10.3(1)
B 227—04	Specification for Hard-drawn Copper-clad Steel Wire	R606.15
B 251—02e01	Specification for General Requirements for Wrought Seamless Copper and Copper-alloy Tube	Table M2101.1
B 302—02	Specification for Threadless Copper Pipe, Standard Sizes.	Table M2101.1
B 306—02	Specification for Copper Drainage Tube (DWV)	Table M2101.1
B 370—03	Specification for Copper Sheet and Strip for Building Construction	Table R905.2.8.2, Table R905.10.3(1)
B 695—04	Standard Specification for Coatings of Zinc Mechanically Deposited on Iron and Steel	R317.3.1, R317.3.3
B 813—00e01	Specification for Liquid and Paste Fluxes for Soldering Applications of Copper and Copper Alloy Tube	Table M2101.1
C 5—03	Specification for Quicklime for Structural Purposes.	R702.2.1

REFERENCED STANDARDS

ASTM—continued

C 27—98 (2002)	Specification for Standard Classification of Fireclay and High-alumina Refractory Brick	R1001.5, R1001.8
C 28/C 28M—00(2005)	Specification for Gypsum Plasters	R702.2.1
C 33—03	Specification for Concrete Aggregates	R403.4.1
C 34—03	Specification for Structural Clay Load-bearing Wall Tile	Table R301.2(1)
C 35—01(2005)	Specification for Inorganic Aggregates for Use in Gypsum Plaster	R702.2.1
C 36/C 36M—03	Specification for Gypsum Wallboard	R702.3.1
C 37/C 37M—01	Specification for Gypsum Lath	R702.2.1, R702.2.2
C 55—06e01	Specification for Concrete Building Brick	R202, Table R301.2(1)
C 59/C 59M—00 (2006)	Specification for Gypsum Casting and Molding Plaster	R702.2
C 61/C 61M—00 (2006)	Specification for Gypsum Keene’s Cement	R702.2.1
C 62—05	Specification for Building Brick (Solid Masonry Units Made from Clay or Shale)	R202, Table R301.2(1)
C 73—05	Specification for Calcium Silicate Face Brick (Sand Lime Brick)	R202, Table R301.2(1)
✓ C 79—04a	Specification for Treated Core and Nontreated Core Gypsum Sheathing Board	R702.3.1
C 90—06b	Specification for Load-bearing Concrete Masonry Units	Table R301.2(1)
C 91—05	Specification for Masonry Cement	R702.2.2
C 94/C 94M—07	Specification for Ready-mixed Concrete	R404.1.2.3.2, R611.5.1.1
C 129—06	Specification for Nonload-bearing Concrete Masonry Units	Table R301.2(1)
C 143/C 143M—05a	Test Method for Slump or Hydraulic Cement Concrete	R404.1.2.3.4, R611.5.1.3, R611.6.1
C 145—85	Specification for Solid Load-bearing Concrete Masonry Units	R202, Table R301.2(1)
C 150—07	Specification for Portland Cement	R702.2.2
C 199—84 (2005)	Test Method for Pier Test for Refractory Mortar	R1001.5, R1001.8, R1003.12
C 203—05a	Standard Test Methods for Breaking Load and Flexural Properties of Block-type Thermal Insulation	Table R613.3.1
C 207—06	Specification for Hydrated Lime for Masonry Purposes	Table R607.1
C 208—95 (2001)	Specification for Cellulosic Fiber Insulating Board	Table R602.3(1)
✓ C 216—07	Specification for Facing Brick (Solid Masonry Units Made from Clay or Shale)	R202, Table R301.2(1)
✓ C 270—07	Specification for Mortar for Unit Masonry	R607.1
C 272—01	Standard Test Method for Water Absorption of Core Materials for Structural Sandwich Constructions	Table R613.3.1
✓ C 273—00e1	Standard Test Method for Shear Properties of Sandwich Core Materials	Table R613.3.1
✓ C 315—07	Specification for Clay Flue Liners and Chimney Pots	G2425.12, R1001.8, R1003.11.1, Table R1003.14(1)
C 406—06e01	Specifications for Roofing Slate	R905.6.4
✓ C 411—05	Test Method for Hot-surface Performance of High-temperature Thermal Insulation	M1601.3
✓ C 475/C 475—05	Specification for Joint Compound and Joint Tape for Finishing Gypsum Wallboard	R702.3.1
✓ C 476—02	Specification for Grout for Masonry	R609.1.1
✓ C 514—04	Specification for Nails for the Application of Gypsum Wallboard	R702.3.1
C 552—03	Standard Specification for Cellular Glass Thermal Insulation	Table R906.2
✓ C 557—03e01	Specification for Adhesives for Fastening Gypsum Wallboard to Wood Framing	R702.3.1
✓ C 578—07	Specification for Rigid, Cellular Polystyrene Thermal Insulation	R403.3, R613.3.1, R703.11.2.1, Table R906.2
C 587—04	Specification for Gypsum Veneer Plaster	R702.2.1
C 588/C 588M—01	Specification for Gypsum Base for Veneer Plasters	R702.2.1, R702.2.2
C 595—07	Specification for Blended Hydraulic Cements	R702.2.2
C 630/C 630M—03	Specification for Water-resistant Gypsum Backing Board	R702.3.1
C 631—95a (2004)	Specification for Bonding Compounds for Interior Gypsum Plastering	R702.2.1
C 645—07	Specification for Nonstructural Steel Framing Members	R702.3.3
C 652—05a	Specification for Hollow Brick (Hollow Masonry Units Made from Clay or Shale)	R202, Table R301.2(1)
✓ C 685—01	Specification for Concrete Made by Volumetric Batching and Continuous Mixing	R404.1.2.3.2, R611.5.1.1
✓ C 728—05	Standard Specification for Perlite Thermal Insulation Board	Table R906.2
C 836—06	Specification for High Solids Content, Cold Liquid-applied Elastomeric Waterproofing Membrane for Use with Separate Wearing Course	R905.15.2
C 843—99 (2006)	Specification for Application of Gypsum Veneer Plaster	R702.2.1
C 844—04	Specification for Application of Gypsum Base to Receive Gypsum Veneer Plaster	R702.2.1
C 847—06	Specification for Metal Lath	R702.2.1, R702.2.2
C 887—05	Specification for Packaged, Dry, Combined Materials for Surface Bonding Mortar	R406.1
C 897—05	Specification for Aggregate for Job-mixed Portland Cement-based Plasters	R702.2.2
C 920—05	Standard Specification for Elastomeric Joint Sealants	R406.4.1
C 926—98a (2005)	Specification for Application of Portland Cement-based Plaster	R702.2.2, R703.6, R703.6.2, R703.6.4
C 931/C 931M—04	Specification for Exterior Gypsum Soffit Board	R702.3.1
C 933—05	Specification for Welded Wire Lath	R702.2.1, R702.2.2

ASTM—continued

C 954—04	Specification for Steel Drill Screws for the Application of Gypsum Panel Products or Metal Plaster Bases to Steel Studs from 0.033 in. (0.84 mm) to 0.112 in. (2.84 mm) in Thickness	R505.2.4, R603.2.4, R702.3.6, R804.2.4
C 955—06	Specification for Load-bearing (Transverse and Axial) Steel Studs, Runners (Tracks), and Bracing or Bridging for Screw Application of Gypsum Panel Products and Metal Plaster Bases.	R702.3.3
C 957—06	Specification for High-solids Content, Cold Liquid-applied Elastomeric Waterproofing Membrane for Use with Integral Wearing Surface	R905.15.2
C 960—04	Specification for Predecorated Gypsum Board	R702.3.1
C 1002—04	Specification for Steel Drill Screws for the Application of Gypsum Panel Products or Metal Plaster Bases	R702.3.1, R702.3.6
C 1029—05a	Specification for Spray-applied Rigid Cellular Polyurethane Thermal Insulation.	R905.14.2
C 1032—06	Specification for Woven Wire Plaster Base	R702.2.1, R702.2.2
C 1047—05	Specification for Accessories for Gypsum Wallboard and Gypsum Veneer Base.	R702.2.1, R702.2.2, R702.3.1
C 1063—06	Specification for Installation of Lathing and Furring to Receive Interior and Exterior Portland Cement-based Plaster.	R702.2.2, R703.6
C 1107—07	Standard Specification for Packaged Dry, Hydraulic-cement Grout (Nonshrink)	R402.3.1
C 1116—06	Standard Specification for Fiber-reinforced Concrete and Shotcrete	R402.3.1
C 1167—03	Specification for Clay Roof Tiles	R905.3.4
C 1177/C 1177M—06	Specification for Glass Mat Gypsum Substrate for Use as Sheathing	R702.3.1
C 1178/C 1178M—06	Specification for Glass Mat Water-resistant Gypsum Backing Panel	R702.3.1, R702.3.8, R702.4.2
C 1186—07	Specification for Flat Nonasbestos Fiber Cement Sheets.	R703.10.1, R703.10.2
C 1261—07	Specification for Firebox Brick for Residential Fireplaces	R1001.5, R1001.8
C 1278/C 1278M—06	Specification for Fiber-reinforced Gypsum Panels	R702.3.1, R702.3.8, R702.4.2
C 1283—07	Practice for Installing Clay Flue Lining.	R1003.12
C 1288—99(2004)	Standard Specification for Discrete Nonasbestos Fiber-cement Interior Substrate Sheets.	R702.4.2
C 1289—07	Standard Specification for Faced Rigid Cellular Polyisocyanurate Thermal Insulation Board	R703.11.2.1, Table R906.2
C 1325—04	Standard Specification for Nonasbestos Fiber-mat Reinforced Cement Interior Substrate Sheets	R702.4.2
C 1328—05	Specification for Plastic (Stucco) Cement.	R702.2.2
C 1395/C 1395M—06a	Specification for Gypsum Ceiling Board	R702.3.1
C 1396/C 1396M—06a	Specification for Gypsum Board	Table R602.3(1), R702.3.1, R702.3.8
C 1492—03	Specification for Concrete Roof Tile.	R905.3.5
C 1513—04	Standard Specification for Steel Tapping Screws for Cold-formed Steel Framing Connections	R505.2.4, R603.2.4, R702.3.6, R804.2.4
C 1658/C 1658M—06	Standard Specification for Glass Mat Gypsum Panels	R702.3.1
D 41—05	Specification for Asphalt Primer Used in Roofing, Dampproofing and Waterproofing.	Table R905.9.2, Table R905.11.2
D 43—00(2006)	Specification for Coal Tar Primer Used in Roofing, Dampproofing and Waterproofing	Table R905.9.2
D 225—04	Specification for Asphalt Shingles (Organic Felt) Surfaced with Mineral Granules	R905.2.4
D 226—06	Specification for Asphalt-saturated (Organic Felt) Used in Roofing and Waterproofing	R703.2, R905.2.3, R905.3.3, R905.4.3, R905.5.3, R905.6.3, R905.7.3, R905.8.3, R905.8.4, Table R905.9.2
D 227—03	Specification for Coal Tar Saturated (Organic Felt) Used in Roofing and Waterproofing	Table R905.9.2
D 312—00(2006)	Specification for Asphalt Used in Roofing	Table R905.9.2
D 422—63(2002)e01	Test Method for Particle-size Analysis of Soils.	R403.1.8.1
D 449—03	Specification for Asphalt Used in Dampproofing and Waterproofing.	R406.2
D 450—07	Specification for Coal-tar Pitch Used in Roofing, Dampproofing and Waterproofing	Table R905.9.2
D 1227—95(2007)	Specification for Emulsified Asphalt Used as a Protective Coating for Roofing	Table R905.9.2, Table R905.11.2, R905.15.2
D 1248—05	Specification for Polyethylene Plastics Extrusion Materials for Wire and Cable	M1601.1.2
D 1621—04a	Standard Test Method for Compressive Properties of Rigid Cellular Plastics	Table R613.3.1
D 1622—03	Standard Test Method for Apparent Density of Rigid Cellular Plastics.	Table R613.3.1
D 1623—78(1995)	Standard Test Method for Tensile and Tensile Adhesion Properties of Rigid Cellular Plastics.	Table R613.3.1
D 1693—07	Test Method for Environmental Stress-cracking of Ethylene Plastics	Table M2101.1
D 1784—06a	Standard Specification for Rigid Poly (Vinyl Chloride) (PVC) Compounds and Chlorinated Poly (Vinyl Chloride) (CPVC) Compounds	M1601.1.2
D 1863—05	Specification for Mineral Aggregate Used in Built-up Roofs.	Table R905.9.2
D 1970—01	Specification for Self-adhering Polymer Modified Bitumen Sheet Materials Used as Steep Roofing Underlayment for Ice Dam Protection	R905.2.3, R905.2.8, R905.4.3
D 2126—04	Standard Test Method for Response of Rigid Cellular Plastics to Thermal and Humid Aging	Table R613.3.1
D 2178—04	Specification for Asphalt Glass Felt Used in Roofing and Waterproofing	Table R905.9.2

REFERENCED STANDARDS

ASTM—continued

	D 2412—02	Test Method for Determination of External Loading Characteristics of Plastic Pipe by Parallel-plate Loading	M1601.1.2
✓	D 2447—03	Specification for Polyethylene (PE) Plastic Pipe Schedules 40 and 80, Based on Outside Diameter	Table M2101.1
	D 2513—07a	Specification for Thermoplastic Gas Pressure Pipe, Tubing and Fittings	G2414.6, G2414.6.1, G2414.11, G2415.15.2, Table M2101.1, M2104.2.1.3
	D 2559—04	Standard Specification for Adhesives for Structural Laminated Wood Products for Use Under Exterior (West Use) Exposure Conditions	R613.3.3
✓	D 2626—04	Specification for Asphalt-saturated and Coated Organic Felt Base Sheet Used in Roofing	R905.3.3, Table R905.9.2
✓	D 2683—04	Specification for Socket-type Polyethylene Fittings for Outside Diameter-controlled Polyethylene Pipe and Tubing	Table M2101.1, M2104.2.1.1
✓	D 2822—05	Specification for Asphalt Roof Cement.	Table R905.9.2
	D 2823—05	Specification for Asphalt Roof Coatings.	Table R905.9.2
	D 2824—06	Specification for Aluminum-pigmented Asphalt Roof Coatings, Nonfibered, Asbestos Fibered and Fibered without Asbestos	Table R905.9.2, Table R905.11.2
	D 2837—04e01	Test Method for Obtaining Hydrostatic Design Basis for Thermoplastic Pipe Materials or Pressure Design Basis for Thermoplastic Pipe Products	Table M2101.1
✓	D 2846/D 2846M—06	Specification for Chlorinated Poly (Vinyl Chloride) (CPVC) Plastic Hot- and Cold-water Distribution Systems	Table M2101.1
✓	D 2898—04	Test Methods for Accelerated Weathering of Fire-retardant-treated Wood for Fire Testing	R802.1.3.4, R802.1.3.6
✓	D 3019—94 (2007)	Specification for Lap Cement Used with Asphalt Roll Roofing, Nonfibered, Asbestos Fibered and Nonasbestos Fibered	Table R905.9.2, Table R905.11.2
✓	D 3035—06	Specification for Polyethylene (PE) Plastic Pipe (DR-PR) Based On Controlled Outside Diameter.	Table M2101.1
	D 3161—06	Test Method for Wind Resistance of Asphalt Shingles (Fan Induced Method).	R905.2.4.1, Table R905.2.4.1(2)
✓	D 3201—07	Test Method for Hygroscopic Properties of Fire-retardant Wood and Wood-base Products.	R802.1.3.7
✓	D 3309—96a (2002)	Specification for Polybutylene (PB) Plastic Hot- and Code-water Distribution System	Table M2101.1
	D 3350—06	Specification for Polyethylene Plastic Pipe and Fitting Materials	Table M2101.1
	D 3462—07	Specification for Asphalt Shingles Made From Glass Felt and Surfaced with Mineral Granules	R905.2.4
	D 3468—99 (2006)e01	Specification for Liquid-applied Neoprene and Chlorosulfanated Polyethylene Used in Roofing and Waterproofing	R905.15.2
	D 3679—06a	Specification for Rigid Poly (Vinyl Chloride) (PVC) Siding	Table R703.4, R703.11
	D 3737—07	Practice for Establishing Allowable Properties for Structural Glued Laminated Timber (Glulam)	R502.1.5, R602.1.2, R802.1.4
	D 3747—79 (2007)	Specification for Emulsified Asphalt Adhesive for Adhering Roof Insulation	Table R905.9.2, Table R905.11.2
	D 3909—97b (2004)e01	Specification for Asphalt Roll Roofing (Glass Felt) Surfaced with Mineral Granules.	R905.2.8.2, R905.5.4, Table R905.9.2
	D 3957—06	Standard Practices for Establishing Stress Grades for Structural Members Used in Log Buildings.	R502.1.6, R602.1.3, R802.1.5
✓	D 4022—07	Specification for Coal Tar Roof Cement, Asbestos Containing	Table R905.9.2
	D 4318—05	Test Methods for Liquid Limit, Plastic Limit and Plasticity Index of Soils	R403.1.8.1
	D 4434—06	Specification for Poly (Vinyl Chloride) Sheet Roofing.	R905.13.2
✓	D 4479—07	Specification for Asphalt Roof Coatings-asbestos-free.	Table R905.9.2
	D 4586—00	Specification for Asphalt Roof Cement-asbestos-free	Table R905.9.2
	D 4601—04	Specification for Asphalt-coated Glass Fiber Base Sheet Used in Roofing	Table R905.9.2
	D 4637—04	Specification for EPDM Sheet Used in Single-ply Roof Membrane	R905.12.2
	D 4829—07	Test Method for Expansion Index of Soils.	R403.1.8.1
	D 4869—05e01	Specification for Asphalt-saturated (Organic Felt) Underlayment Used in Steep Slope Roofing.	R905.2.3, R905.4.3, R905.5.3, R905.6.3, R905.7.3, R905.8.3
	D 4897—01	Specification for Asphalt Coated Glass-fiber Venting Base Sheet Used in Roofing	Table R905.9.2
	D 4990—97a (2005)e01	Specification for Coal Tar Glass Felt Used in Roofing and Waterproofing	Table R905.9.2
	D 5019—07	Specification for Reinforced Nonvulcanized Polymeric Sheet Used in Roofing Membrane	R905.12.2
	D 5055—05	Specification for Establishing and Monitoring Structural Capacities of Prefabricated Wood I-joists	R502.1.4
	D 5516—03	Test Method for Evaluating the Flexural Properties of Fire-retardant-treated Softwood Plywood Exposed to the Elevated Temperatures.	R802.1.3.5.1
	D 5643—06	Specification for Coal Tar Roof Cement Asbestos-free	Table R905.9.2
	D 5664—02	Test Methods For Evaluating the Effects of Fire-retardant Treatments and Elevated Temperatures on Strength Properties of Fire-retardant-treated Lumber.	R802.1.3.5.2
	D 5665—99a(2006)	Specification for Thermoplastic Fabrics Used in Cold-applied Roofing and Waterproofing	Table R905.9.2
	D 5726—98(2005)	Specification for Thermoplastic Fabrics Used in Hot-applied Roofing and Waterproofing	Table R905.9.2
	D 6083—05e01	Specification for Liquid-applied Acrylic Coating Used in Roofing	Table R905.9.2, Table R905.11.2, R905.15.2
	D 6162—00a	Specification for Styrene Butadiene Styrene (SBS) Modified Bituminous Sheet Materials Using a Combination of Polyester and Glass Fiber Reinforcements	Table R905.11.2

ASTM—continued

D 6163—00e01	Specification for Styrene Butadiene Styrene (SBS) Modified Bituminous Sheet Materials Using Glass Fiber Reinforcements	Table R905.11.2
D 6164—05	Specification for Styrene Butadiene Styrene (SBS) Modified Bituminous Sheet Materials Using Polyester Reinforcements	Table R905.11.2
D 6222—02e01	Specification for Atactic Polypropylene (APP) Modified Bituminous Sheet Materials Using Polyester Reinforcement	Table R905.11.2
D 6223—02e01	Specification for Atactic Polypropylene (APP) Modified Bituminous Sheet Materials Using a Combination of Polyester and Glass Fiber Reinforcement	Table R905.11.2
D 6298—05	Specification for Fiberglass-reinforced Styrene Butadiene Styrene (SBS) Modified Bituminous Sheets with a Factory Applied Metal Surface	Table R905.11.2
D 6305—02e01	Practice for Calculating Bending Strength Design Adjustment Factors for Fire-retardant-treated Plywood Roof Sheathing	R802.1.3.5.1
D 6380—03	Standard Specification for Asphalt Roll Roofing (Organic Felt)	R905.2.8.2, R905.3.3, R905.5.4
D 6694—07	Standard Specification Liquid-applied Silicone Coating Used in Spray Polyurethane Foam Roofing	R905.15.2
D 6754—02	Standard Specification for Ketone-ethylene-ester-based Sheet Roofing	R905.13.2
D 6757—07	Standard Specification for Inorganic Underlayment for Use with Steep Slope Roofing Products	R905.2.3
D 6841—03	Standard Practice for Calculating Design Value Treatment Adjustment Factors for Fire-retardant-treated Lumber	R802.1.3.5.2
D 6878—06a	Standard Specification for Thermoplastic-polyolefin-based Sheet Roofing	R905.13.2
D 6947—07	Standard Specification for Liquid Applied Moisture Cured Polyurethane Coating Used in Spray Polyurethane Foam Roofing System	R905.15.2
D 7032—07	Standard Specification for Establishing Performance Ratings for Wood-plastic Composite Deck Boards and Guardrail Systems (Guards or Handrails)	R317.4
D 7158—07	Standard Test Method for Wind Resistance of Sealed Asphalt Shingles (Uplift Force/Uplift Resistance Method)	R905.2.4.1, Table R905.2.4.1(1)
E 84—07	Test Method for Surface Burning Characteristics of Building Materials	M1601.3, M1601.5.2, R202, R302.9.3, R302.9.4, R302.10.1, R302.10.2, R316.3, R316.5.9, R316.5.11, R802.1.3
E 90—04	Test Method for Laboratory Measurement of Airborne Sound Transmission Loss of Building Partitions and Elements	AK102, AK102.1.1
E 96/E 96M—05	Test Method for Water Vapor Transmission of Materials	M1411.5, M1601.4.5, R202, Table R613.3.1
E 108—07a	Test Methods for Fire Tests of Roof Coverings	R902.1
E 119—07	Test Methods for Fire Tests of Building Construction and Materials	Table R302.1, R302.2, R302.3, R302.4.1, R316.4
E 136—04	Test Method for Behavior of Materials in a Vertical Tube Furnace at 750°C	R202, R302.11
E 283-04	Test Method of Determining the Rate of Air Leakage through Exterior Windows, Curtain Walls and Doors Under Specified Pressure Difference Across the Specimen	N1104.8.1
E 330—02	Test Method for Structural Performance of Exterior Windows, Curtain Walls and Doors by Uniform Static Air Pressure Difference	R612.7, R612.8, R703.1.2
E 331—00	Test Method for Water Penetration of Exterior Windows, Skylights, Doors and Curtain Walls by Uniform Static Air Pressure Difference	R703.1.1
E 492—04	Specification for Laboratory Measurement of Impact Sound Transmission through Floor-ceiling Assemblies Using the Tapping Machine	AK103
E 814—06	Test Method for Fire Tests of Through-penetration Firestops	R302.4.1.2
E 970—00	Test Method for Critical Radiant Flux of Exposed Attic Floor Insulation Using a Radiant Heat Energy Source	R302.10.5
E 1509—04	Standard Specification for Room Heaters, Pellet Fuel-burning Type	M1410.1
E 1602—03	Guide for Construction of Solid Fuel Burning Masonry Heaters	R1002.2
E 1886—06	Test Method for Performance of Exterior Windows, Curtain Walls, Doors and Storm Shutters Impacted by Missiles and Exposed to Cyclic Pressure Differentials	R301.2.1.2, R612.9.1
E 1996—06	Standard Specification for Performance of Exterior Windows, Curtain Walls, Doors and Impact Protective Systems Impacted by Windborne Debris in Hurricanes	R301.2.1.2, R612.9.1
E 2178—03	Standard Test Method for Air Permeance of Building Materials	R202
E 2231—04	Standard Practice for Specimen Preparation and Mounting of Pipe and Duct Insulation Materials to Assess Surface Burning Characteristics	M1601.3
E 2273—03	Standard Test Method for Determining the Drainage Efficiency of Exterior Insulation and Finish Systems (EIFS) Clad Wall Assemblies	R703.9.2
E 2568—07	Standard Specification for PB Exterior Insulation and Finish Systems (EIFS)	R703.9.1, R703.9.2
E 2570—07	Standard Test Methods for Evaluating Water-resistive Barrier (WRB) Coatings Used Under Exterior Insulation and Finish Systems (EIFS) or EIFS with Drainage	R703.9.2.1
F 876—06	Specification for Cross-linked Polyethylene (PEX) Tubing	Table M2101.1
F 877—07	Specification for Cross-linked Polyethylene (PEX) Plastic Hot- and Cold-water Distribution Systems	Table M2101.1
F 1055—98(2006)	Specification for Electrofusion Type Polyethylene Fittings for Outside Diameter Controlled Polyethylene Pipe and Fittings	Table M2101.1, M2104.2.1.2
F 1281—07	Specification for Cross-linked Polyethylene/Aluminum/Cross-linked Polyethylene (PEX-AL-PEX) Pressure Pipe	Table M2101.1
F 1282—06	Specification for Polyethylene/Aluminum/Polyethylene (PE-AL-PE) Composite Pressure Pipe	Table M2101.1



REFERENCED STANDARDS

ASTM—continued

>	F 1346—91(2003)	Performance Specification for Safety Covers and Labeling Requirements for All Covers for Swimming Pools, Spas and Hot Tubs	AG105.2, AG105.5
>	F 1554—04e1	Specification for Anchor Bolts, Steel, 36, 55 and 105-ksi Yield Strength.	R611.5.2.2
	F 1667—05	Specification for Driven Fasteners, Nails, Spikes and Staples	Table R703.4, R905.2.5
>	F 1807—07	Specification for Metal Insert Fittings Utilizing a Copper Crimp Ring for SDR9 Cross-linked Polyethylene (PEX) Tubing	Table M2101.1
	F 1960—07	Specification for Cold Expansion Fittings with PEX Reinforcing Rings for Use with Cross-linked Polyethylene (PEX) Tubing	Table M2101.1
	F 1973—05	Standard Specification for Factory Assembled Anodeless Risers and Transition Fittings in Polyethylene (PE) and Polyamide 11 (PA 11) Fuel Gas Distribution Systems	G2415.15.2
>	F 2090—01A(2007)	Specification for Window Fall Prevention Devices—with Emergency Escape (Egress) Release Mechanisms.	R612.2, R612.3
	F 2098—04e1	Standard Specification for Stainless Steel Clamps for SDR9 PEX Tubing to Metal Insert Fittings	Table M2101.1
>	F 2389—06	Standard for Pressure-rated Polypropylene (PP) Piping Systems	Table M2101.1
	F 2623—07	Standard Specification for Polyethylene of Raised Temperature (PE-RT) SDRG Tubing	Table M2101.1

AWPA

American Wood Protection Association
P.O. Box 361784
Birmingham, AL 35236-1784

Standard reference number	Title	Referenced in code section number
C1—03	All Timber Products—Preservative Treatment by Pressure Processes	R902.2
M4—06	Standard for the Care of Preservative-treated Wood Products	R317.1.1, R318.1.2
U1—07	USE CATEGORY SYSTEM: User Specification for Treated Wood Except Section 6 Commodity Specification H	R317.1, R322.1.8, R402.1.2, R504.3, Table R905.8.5

CGSB

Canadian General Standards Board
Place du Portage 111, 6B1
11 Laurier Street
Gatineau, Quebec, Canada KIA 1G6

Standard reference number	Title	Referenced in code section number
37-GP—52M—(1984)	Roofing and Waterproofing Membrane, Sheet Applied, Elastomeric.	R905.12.2
37-GP—56M—(1980)	Membrane, Modified Bituminous, Prefabricated and Reinforced for Roofing —with December 1985 Amendment.	Table R905.11.2
CAN/CGSB-37.54—95	Polyvinyl Chloride Roofing and Waterproofing Membrane	R905.13.2

CPA

Composite Panel Association
19465 Deerfield Avenue, Suite 306
Leesburg, VA 20176

Standard reference number	Title	Referenced in code section number
ANSI A135.4—04	Basic Hardboard.	Table R602.3(2)
ANSI A135.5—04	Prefinished Hardboard Paneling	R702.5
ANSI A135.6—98	Hardboard Siding	Table R703.4

CPSC

Consumer Product Safety Commission
4330 East West Highway
Bethesda, MD 20814-4408

Standard reference number	Title	Referenced in code section number
16 CFR Part 1201—(1977)	Safety Standard for Architectural Glazing	R308.1.1, R308.3.1
16 CFR Part 1209—(1979)	Interim Safety Standard for Cellulose Insulation	R302.10.3
16 CFR Part 1404—(1979)	Cellulose Insulation.	R302.10.3

CSA

Canadian Standards Association
5060 Spectrum Way
Mississauga, Ontario, Canada L4N 5N6

Standard reference number	Title	Referenced in code section number
CSA Requirement 3—88	Manually Operated Gas Valves for Use in House Piping Systems	Table G2420.1.1
CSA 8-93	Requirements for Gas Fired Log Lighters for Wood Burning Fireplaces —with Revisions through January 1999G2433.1
O325—07	Construction SheathingR503.2.1
O437-Series—93	Standards on OSB and Waferboard (Reaffirmed 2006)R503.2.1, R803.2.1
101/I.S.2/A440—08	Specifications for Windows, Doors and Unit SkylightsR308.6.9, R612.6
CAN/CSA B137.10M—02	Cross-linked Polyethylene/Aluminum/Polyethylene Composite Pressure Pipe Systems	Table M2101.1

CSSB

Cedar Shake & Shingle Bureau
P. O. Box 1178
Sumas, WA 98295-1178

Standard reference number	Title	Referenced in code section number
CSSB—97	Grading and Packing Rules for Western Red Cedar Shakes and Western Red Shingles of the Cedar Shake and Shingle Bureau	R702.6, R703.5, Table R905.7.4, Table R905.8.5

DASMA

Door and Access Systems Manufacturers
Association International
1300 Summer Avenue
Cleveland, OH 44115-2851

Standard reference number	Title	Referenced in code section number
108—05	Standard Method for Testing Garage Doors: Determination of Structural Performance Under Uniform Static Air Pressure DifferenceR612.7
115—05	Standard Method for Testing Garage Doors: Determination of Structural Performance Under Missile Impact and Cyclic Wind PressureR301.2.1.2

DOC

United States Department of Commerce
1401 Constitution Avenue, NW
Washington, DC 20230

Standard reference number	Title	Referenced in code section number
PS 1—07	Structural Plywood	R404.2.1, Table R404.2.3, R503.2.1, R604.1, R613.3.2, R803.2.1
PS 2—04	Performance Standard for Wood-based Structural-use Panels	R404.2.1, Table R404.2.3, R503.2.1, R604.1, R613.3.2, Table 613.3.2, R803.2.1
PS 20—05	American Softwood Lumber Standard	R404.2.1, R502.1, R602.1, R802.1

DOTn

Department of Transportation
1200 New Jersey Avenue SE
East Building, 2nd floor
Washington, DC 20590

Standard reference number	Title	Referenced in code section number
49 CFR, Parts 192.281(e) & 192.283 (b)	Transportation of Natural and Other Gas by Pipeline: Minimum Federal Safety Standards	G2414.6.1



REFERENCED STANDARDS

FEMA

Federal Emergency Management Agency
500 C Street, SW
Washington, DC 20472

Standard reference number	Title	Referenced in code section number
TB-2—93	Flood-resistant Materials Requirements	R322.1.8
FIA-TB-11—01	Crawlspace Construction for Buildings Located in Special Flood Hazard Area.	R408.7

FM

Factory Mutual Global Research
Standards Laboratories Department
1301 Atwood Avenue, P. O. Box 7500
Johnson, RI 02919

Standard reference number	Title	Referenced in code section number
4450—(1989)	Approval Standard for Class 1 Insulated Steel Deck Roofs—with Supplements through July 1992.	R906.1
4470—(1986)	25-foot and 50-foot High Corner Tests (Section 5.4).	R314.2.1.2
4471—(1995)	Test Method For Wind Up-lift	R314.2.1.2
4880—(2005)	American National Standard for Evaluating Insulated Wall or Wall and Roof/Ceiling Assemblies, Plastic Interior Finish Materials, Plastic Exterior Building Panels, Wall/Ceiling Coating Systems, Interior or Exterior Finish Systems.	R316.4, R316.6

GA

Gypsum Association
810 First Street, Northeast, Suite 510
Washington, DC 20002-4268

Standard reference number	Title	Referenced in code section number
GA-253—07	Application of Gypsum Sheathing.	Table R602.3(1)

HPVA

Hardwood Plywood & Veneer Association
1825 Michael Faraday Drive
Reston, Virginia 20190-5350

Standard reference number	Title	Referenced in code section number
HP-1—2004	The American National Standard for Hardwood and Decorative Plywood.	R702.5

ISO

International Organization for Standardization
1, ch. de la Voie - Creuse
Case postale 56
CH-1211 Geneva 20, Switzerland

Standard reference number	Title	Referenced in code section number
15874—2002	Polypropylene Plastic Piping Systems for Hot and Cold Water Installations.	Table M2101.1

MSS

Manufacturers Standardization Society of the Valve and Fittings Industry
127 Park Street, Northeast
Vienna, VA 22180

Standard reference number	Title	Referenced in code section number
SP-58—93	Pipe Hangers and Supports—Materials, Design and Manufacture	G2418.2

NAIMA

North American Insulation Manufacturers Association
44 Canal Center Plaza, Suite 310
Alexandria, VA 22314

Standard reference number	Title	Referenced in code section number
AH 116—02	Fibrous Glass Duct Construction Standards, Fifth EditionM1601.1.1

NCMA

National Concrete Masonry Association
13750 Sunrise Valley Drive
Herndon, VA 20171-4662

Standard reference number	Title	Referenced in code section number
TR 68-A—75	Design and Construction of Plain and Reinforced Concrete Masonry and Basement and Foundation Walls.R404.1.1

NFPA

National Fire Protection Association
1 Batterymarch Park
Quincy, MA 02269

Standard reference number	Title	Referenced in code section number
13—07	Installation of Sprinkler SystemsR302.3
31—06	Installation of Oil-burning EquipmentM1801.3.1, M1805.3
37—98	Standard For Installation And Use of Stationary Combustion Engines and Gas Turbines	G2439.1
54—99	National Fuel Gas CodeG2417.4.1
58—08	Liquefied Petroleum Gas CodeG2412.2, G2414.6.2
72—07	National Fire Alarm Code.R314.1, R314.2
85—07	Boiler and Construction Systems Hazards CodeG2452.1
211—06	Chimneys, Fireplaces, Vents and Solid Fuel Burning Appliances.G2427.5.5.1, R1002.5
259—03	Test Method for Potential Heat of Building MaterialsR316.5.7, 316.5.8
286—06	Standard Methods of Fire Tests for Evaluating Contribution of Wall and Ceiling Interior Finish to Room Fire Growth.R302.9.4, R316.4, R316.5.8, R316.6
501—05	Standard on Manufactured Housing.R202, AE201
853—07	Standard for the Installation of Stationary Fuel Cell Power SystemsM1903.1

PCA

Portland Cement Association
5420 Old Orchard Road
Skokie, IL 60077

Standard reference number	Title	Referenced in code section number
100—07	Prescriptive Design of Exterior Concrete Walls for One- and Two-family Dwellings (Pub. No. EB241)R404.1.2, R404.1.2.2.1, R404.1.2.2.2, R404.1.2.4, R404.1.4.2, R611.1, R611.2, R611.9.2, R611.9.3

SMACNA

Sheet Metal & Air Conditioning Contractors National Assoc. Inc.
4021 Lafayette Center Road
Chantilly, VA 22021

Standard reference number	Title	Referenced in code section number
SMACNA—03	Fibrous Glass Duct Construction Standards (2003)M1601.1.1

REFERENCED STANDARDS

TMS

The Masonry Society
3970 Broadway, Suite 201-D
Boulder, CO 80304

Standard reference number	Title	Referenced in code section number
302—07	Standard Method for Determining the Sound Transmission Class Rating for Masonry Walls	AK102.1.1
402—08	Building Code Requirements for Masonry Structures	R404.1.1, R606.1, R606.1.1, R606.11.2.2.2, R606.12.1, R606.12.2.3.1, R606.12.2.3.2, R606.12.3.1, Table R703.4
602—08	Specification for Masonry Structures	R404.1.1, R606.1, R606.1.1, R606.12.1, R606.12.2.3.1, R606.12.2.3.2, R606.12.3.1, Table R703.4

TPI

Truss Plate Institute
583 D’Onofrio Drive, Suite 200
Madison, WI 53719

Standard reference number	Title	Referenced in code section number
TPI 1—2007	National Design Standard for Metal-plate-connected Wood Truss Construction	R502.11.1, R802.10.2

UL

Underwriters Laboratories, Inc.
333 Pfingsten Road
Northbrook, IL 60062

Standard reference number	Title	Referenced in code section number
17—94	Vent or Chimney Connector Dampers for Oil-fired Appliances—with Revisions through September 1999	M1802.2.2
58—96	Steel Underground Tanks for Flammable and Combustible Liquids—with Revisions through July 1998	M2201.1
80—04	Steel Tanks for Oil-burner Fuel	M2201.1
103—01	Factory-built Chimneys for Residential Type and Building Heating Appliances— with Revisions through June 2006.	G2430.1, R202, R1005.3
127—96	Factory-built Fireplaces—with Revisions through November 2006.	G2445.7, R1001.11, R1004.1, R1004.4, R1005.4
174—04	Household Electric Storage Tank Water Heaters—with Revisions through November 2005	M2005.1
181—05	Factory-made Air Ducts and Air Connectors—with Revisions through May 2003	M1601.2, M1601.4.1
181A—05	Closure Systems for Use with Rigid Air Ducts and Air Connectors— with Revisions through December 1998	M1601.2, M1601.4.1
181B—05	Closure Systems for Use with Flexible Air Ducts and Air Connectors— with Revisions through August 2003.	M1601.2, M1601.4.1
217—06	Single- and Multiple-station Smoke Alarms—with Revisions through January 2004	R313.1
263—03	Standards for Fire Test of Building Construction and Materials.	R302.2, R302.4.1, R316.4
325—02	Standard for Door, Drapery, Gate, Louver and Window Operations and Systems —with Revisions through February 2006	R309.4
343—97	Pumps for Oil-burning Appliances—with Revisions through May 2002.	M2204.1
441—96	Gas Vents—with Revisions through August 2006.	G2426.1
508—99	Industrial Control Equipment—with Revisions through July 2005.	M1411.3.1
536—97	Flexible Metallic Hose—with Revisions through June 2003	M2202.3
641—95	Type L, Low-temperature Venting Systems—with Revisions through August 2005.	G2426.1, M1804.2.4, R202, R1003.11.5
651—05	Schedule 40 and Schedule 80 Rigid PVC Conduit and Fittings.	G2414.6.3
723—03	Standard for Test for Surface Burning Characteristics of Building Materials— with Revisions through May 2005	M1601.3, R302.9.3, R302.10.1, R302.10.2, R316.3, R316.6
726—95	Oil-fired Boiler Assemblies—with Revisions through March 2006.	M2001.1.1, M2006.1
727—06	Oil-fired Central Furnaces	M1402.1
729—03	Oil-fired Floor Furnaces	M1408.1
730—03	Oil-fired Wall Furnaces	M1409.1
732—95	Oil-fired Storage Tank Water Heaters—with Revisions through February 2005	M2005.1
737—96	Fireplaces Stoves—with Revisions through January 2000	M1414.1
790—04	Standard Test Methods for Fire Tests of Roof Coverings	R902.1
795—06	Commercial-industrial Gas Heating Equipment	G2442.1, G2452.1
834—04	Heating, Water Supply and Power Boilers-Electric	M2001.1.1
896—93	Oil-burning Stoves—with Revisions through May 2004	M1410.1

UL—continued

923—02	Microwave Cooking Appliances—with Revisions through February 2006	M1504.1
959—01	Medium Heat Appliance Factory-built Chimneys—with Revisions through September 2006.	R1005.6
1040—96	Fire Test of Insulated Wall Construction—with Revisions through June 2001	R316.4, R316.6
1256—02	Fire Test of Roof Deck Construction	R906.1
1261—01	Electric Water Heaters for Pools and Tubs—with Revisions through June 2004.	M2006.1
1453—04	Electronic Booster and Commercial Storage Tank Water Heaters	M2005.1
1479—03	Fire Tests of Through-penetration Firestops	R302.4.1.2
1482—98	Solid-fuel-type Room Heaters—with Revisions through January 2000	M1410.1, R1002.2, R1002.5
1715—97	Fire Test of Interior Finish Material—with Revisions through March 2004.	R316.4
1738—06	Venting Systems for Gas-burning Appliances, Categories II, III and IV.	G2426.1
1777—04	Standard for Chimney Liners	G2425.12, G2425.15.4, M1801.3.4, R1003.11.1, R1003.18
1995—05	Heating and Cooling Equipment	M1402.1, M1403.1, M1407.1
2017—2000	Standard for General-purpose Signaling Devices and Systems—with Revisions through June 2004	AG105.2
2034—2008	Standard for Single- and Multiple-station Carbon Monoxide Alarms.	R315.3
2158A—2006	Outline of Investigation for Clothes Dryer Transition Duct.	M1502.4.3

ULC

Underwriters' Laboratories of Canada
 7 Underwriters Road
 Toronto, Ontario, Canada M1R 3B4

Standard reference number	Title	Referenced in code section number
CAN/ULC S 102—1988	Standard Methods for Test for Surface Burning Characteristics of Building Materials and Assemblies—with 2000 Revisions	R302.10.2

WDMA

Window & Door Manufacturers Association
 1400 East Touhy Avenue, Suite 470
 Des Plaines, IL 60018

Standard reference number	Title	Referenced in code section number
AAMA/WDMA/CSA 101/LS2/A440—08	Specifications for Windows, Doors and Skylights	R308.6.9, R613.6

WWPA

Western Wood Products Association
 522 S.E. Fifth Avenue
 Portland, Oregon 97204-2122

Standard reference number	Title	Referenced in code section number
WWPA—92	Western Lumber Span Tables.	R301.2.3, R501.2, R802.5

APPENDIX A

SIZING AND CAPACITIES OF GAS PIPING

(Not Adopted by the State of Oregon)

(This appendix is informative and is not part of the *code*. This appendix is an excerpt from the 2009 *International Fuel Gas Code*, coordinated with the section numbering of the *International Residential Code*.)

A.1 General piping considerations. The first goal of determining the *pipe* sizing for a *fuel gas piping system* is to make sure that there is sufficient gas pressure at the inlet to each *appliance*. The majority of systems are residential and the *appliances* will all have the same, or nearly the same, requirement for minimum gas pressure at the *appliance* inlet. This pressure will be about 5-inch water column (w.c.) (1.25 kPa), which is enough for proper operation of the *appliance regulator* to deliver about 3.5-inches water column (w.c.) (875 kPa) to the *burner* itself. The *pressure drop* in the *piping* is subtracted from the source delivery pressure to verify that the minimum is available at the *appliance*.

There are other systems, however, where the required inlet pressure to the different *appliances* may be quite varied. In such cases, the greatest inlet pressure required must be satisfied, as well as the farthest *appliance*, which is almost always the critical *appliance* in small systems.

There is an additional requirement to be observed besides the capacity of the system at 100-percent flow. That requirement is that at minimum flow, the pressure at the inlet to any *appliance* does not exceed the pressure rating of the *appliance regulator*. This would seldom be of concern in small systems if the source pressure is $\frac{1}{2}$ psi (14-inch w.c.) (3.5 kPa) or less but it should be verified for systems with greater gas pressure at the point of supply.

To determine the size of *piping* used in a *gas piping system*, the following factors must be considered:

- (1) Allowable loss in pressure from point of delivery to *equipment*.
- (2) Maximum *gas demand*.
- (3) Length of *piping* and number of fittings.
- (4) *Specific gravity* of the gas.
- (5) Diversity factor.

For any *gas piping system*, or special *appliance*, or for conditions other than those covered by the tables provided in this *code*, such as longer runs, greater *gas demands* or greater *pressure drops*, the size of each *gas piping system* should be determined by standard engineering practices acceptable to the *code official*.

A.2 Description of tables

A.2.1 General. The quantity of gas to be provided at each *outlet* should be determined, whenever possible, directly

from the manufacturer's gas input *Btu/h* rating of the *appliance* that will be installed. In case the ratings of the appliances to be installed are not known, Table G2413.2 shows the approximate consumption (in *Btu* per hour) of certain types of typical household *appliances*.

To obtain the cubic feet per hour of gas required, divide the total *Btu/h* input of all *appliances* by the average *Btu* heating value per *cubic foot* of the gas. The average *Btu* per *cubic foot* of the gas in the area of the installation can be obtained from the serving gas supplier.

A.2.2 Low pressure natural gas tables. Capacities for gas at low pressure [less than 2.0 psig (13.8 kPa gauge)] in cubic feet per hour of 0.60 *specific gravity* gas for different sizes and lengths are shown in Table G2413.4(1) for iron *pipe* or equivalent rigid *pipe*, in Table G2413.4(3) for smooth wall semi-rigid *tubing*, in Table G2413.4(5) for corrugated stainless steel *tubing* and in Table G2413.4(7) for polyethylene plastic *pipe*. Tables G2413.4(1), G2413.4(3), G2413.4(5) and G2413.4(7) are based upon a *pressure drop* of 0.5-inch w.c. (125 Pa). In using these tables, an allowance (in equivalent length of *pipe*) should be considered for any *piping* run with four or more fittings [see Table A.2.2].

A.2.3 Undiluted liquefied petroleum tables. Capacities in thousands of *Btu* per hour of undiluted liquefied petroleum gases based on a *pressure drop* of 0.5-inch w.c. (125 Pa) for different sizes and lengths are shown in the *International Fuel Gas Code*. See Appendix A of that *code*.

A.2.4 Natural gas specific gravity. *Gas piping systems* that are to be supplied with gas of a *specific gravity* of 0.70 or less can be sized directly from the tables provided in this *code*, unless the *code official* specifies that a gravity factor be applied. Where the *specific gravity* of the gas is greater than 0.70, the gravity factor should be applied.

Application of the gravity factor converts the figures given in the tables provided in this *code* to capacities for another gas of different *specific gravity*. Such application is accomplished by multiplying the capacities given in the tables by the multipliers shown in Table A.2.4. In case the exact *specific gravity* does not appear in the table, choose the next higher value *specific gravity* shown.

**TABLE A.2.2
EQUIVALENT LENGTHS OF PIPE FITTINGS AND VALVES**

		SCREWED FITTINGS ¹				90° WELDING ELBOWS AND SMOOTH BENDS ²					
		45°/EII	90°/EII	180° close return bends	Tee	R/d = 1	R/d = 1 ¹ / ₃	R/d = 2	R/d = 4	R/d = 6	R/d = 8
k factor =		0.42	0.90	2.00	1.80	0.48	0.36	0.27	0.21	0.27	0.36
L/d' ratio⁴ n =		14	30	67	60	16	12	9	7	9	12
Nominal pipe size, inches	Inside diameter <i>d</i> , inches, Schedule 40 ⁶	L = Equivalent Length In Feet of Schedule 40 (Standard-Weight) Straight Pipe⁶									
1/2	0.622	0.73	1.55	3.47	3.10	0.83	0.62	0.47	0.36	0.47	0.62
3/4	0.824	0.96	2.06	4.60	4.12	1.10	0.82	0.62	0.48	0.62	0.82
1	1.049	1.22	2.62	5.82	5.24	1.40	1.05	0.79	0.61	0.79	1.05
1 1/4	1.380	1.61	3.45	7.66	6.90	1.84	1.38	1.03	0.81	1.03	1.38
1 1/2	1.610	1.88	4.02	8.95	8.04	2.14	1.61	1.21	0.94	1.21	1.61
2	2.067	2.41	5.17	11.5	10.3	2.76	2.07	1.55	1.21	1.55	2.07
2 1/2	2.469	2.88	6.16	13.7	12.3	3.29	2.47	1.85	1.44	1.85	2.47
3	3.068	3.58	7.67	17.1	15.3	4.09	3.07	2.30	1.79	2.30	3.07
4	4.026	4.70	10.1	22.4	20.2	5.37	4.03	3.02	2.35	3.02	4.03
5	5.047	5.88	12.6	28.0	25.2	6.72	5.05	3.78	2.94	3.78	5.05
6	6.065	7.07	15.2	33.8	30.4	8.09	6.07	4.55	3.54	4.55	6.07
8	7.981	9.31	20.0	44.6	40.0	10.6	7.98	5.98	4.65	5.98	7.98
10	10.02	11.7	25.0	55.7	50.0	13.3	10.0	7.51	5.85	7.51	10.0
12	11.94	13.9	29.8	66.3	59.6	15.9	11.9	8.95	6.96	8.95	11.9
14	13.13	15.3	32.8	73.0	65.6	17.5	13.1	9.85	7.65	9.85	13.1
16	15.00	17.5	37.5	83.5	75.0	20.0	15.0	11.2	8.75	11.2	15.0
18	16.88	19.7	42.1	93.8	84.2	22.5	16.9	12.7	9.85	12.7	16.9
20	18.81	22.0	47.0	105.0	94.0	25.1	18.8	14.1	11.0	14.1	18.8
24	22.63	26.4	56.6	126.0	113.0	30.2	22.6	17.0	13.2	17.0	22.6

(continued)

TABLE A.2.2—continued
EQUIVALENT LENGTHS OF PIPE FITTINGS AND VALVES

		MITER ELBOWS ³ (No. of miters)					WELDING TEES		VALVES (screwed, flanged, or welded)			
		1-45°	1-60°	1-90°	2-90° ⁵	3-90° ⁵	Forged	Miter ³	Gate	Globe	Angle	Swing Check
k factor =		0.45	0.90	1.80	0.60	0.45	1.35	1.80	0.21	10	5.0	2.5
L/d' ratio⁴ n =		15	30	60	20	15	45	60	7	333	167	83
Nominal pipe size, inches	Inside diameter <i>d</i> , inches, Schedule 40 ⁶	L = Equivalent Length In Feet of Schedule 40 (Standard-Weight) Straight Pipe⁶										
1/2	0.622	0.78	1.55	3.10	1.04	0.78	2.33	3.10	0.36	17.3	8.65	4.32
3/4	0.824	1.03	2.06	4.12	1.37	1.03	3.09	4.12	0.48	22.9	11.4	5.72
1	1.049	1.31	2.62	5.24	1.75	1.31	3.93	5.24	0.61	29.1	14.6	7.27
1 1/4	1.380	1.72	3.45	6.90	2.30	1.72	5.17	6.90	0.81	38.3	19.1	9.58
1 1/2	1.610	2.01	4.02	8.04	2.68	2.01	6.04	8.04	0.94	44.7	22.4	11.2
2	2.067	2.58	5.17	10.3	3.45	2.58	7.75	10.3	1.21	57.4	28.7	14.4
2 1/2	2.469	3.08	6.16	12.3	4.11	3.08	9.25	12.3	1.44	68.5	34.3	17.1
3	3.068	3.84	7.67	15.3	5.11	3.84	11.5	15.3	1.79	85.2	42.6	21.3
4	4.026	5.04	10.1	20.2	6.71	5.04	15.1	20.2	2.35	112.0	56.0	28.0
5	5.047	6.30	12.6	25.2	8.40	6.30	18.9	25.2	2.94	140.0	70.0	35.0
6	6.065	7.58	15.2	30.4	10.1	7.58	22.8	30.4	3.54	168.0	84.1	42.1
8	7.981	9.97	20.0	40.0	13.3	9.97	29.9	40.0	4.65	222.0	111.0	55.5
10	10.02	12.5	25.0	50.0	16.7	12.5	37.6	50.0	5.85	278.0	139.0	69.5
12	11.94	14.9	29.8	59.6	19.9	14.9	44.8	59.6	6.96	332.0	166.0	83.0
14	13.13	16.4	32.8	65.6	21.9	16.4	49.2	65.6	7.65	364.0	182.0	91.0
16	15.00	18.8	37.5	75.0	25.0	18.8	56.2	75.0	8.75	417.0	208.0	104.0
18	16.88	21.1	42.1	84.2	28.1	21.1	63.2	84.2	9.85	469.0	234.0	117.0
20	18.81	23.5	47.0	94.0	31.4	23.5	70.6	94.0	11.0	522.0	261.0	131.0
24	22.63	28.3	56.6	113.0	37.8	28.3	85.0	113.0	13.2	629.0	314.0	157.0

For SI: 1 foot = 305 mm, 1 degree = 0.01745 rad.

Note: Values for welded fittings are for conditions where bore is not obstructed by weld spatter or backing rings. If appreciably obstructed, use values for "Screwed Fittings."

1. Flanged fittings have three-fourths the resistance of screwed elbows and tees.
2. Tabular figures give the extra resistance due to curvature alone to which should be added the full length of travel.
3. Small size socket-welding fittings are equivalent to miter elbows and miter tees.
4. Equivalent resistance in number of diameters of straight pipe computed for a value of $(f - 0.0075)$ from the relation $(n - k/4f)$.
5. For condition of minimum resistance where the centerline length of each miter is between d and $2\frac{1}{2}d$.
6. For pipe having other inside diameters, the equivalent resistance may be computed from the above n values.

Source: Crocker, S. *Piping Handbook*, 4th ed., Table XIV, pp. 100-101. Copyright 1945 by McGraw-Hill, Inc. Used by permission of McGraw-Hill Book Company.

TABLE A.2.4
MULTIPLIERS TO BE USED WITH TABLES G2413.4(1)
THROUGH G2413.4(8) WHERE THE SPECIFIC GRAVITY
OF THE GAS IS OTHER THAN 0.60

SPECIFIC GRAVITY	MULTIPLIER	SPECIFIC GRAVITY	MULTIPLIER
0.35	1.31	1.00	0.78
0.40	1.23	1.10	0.74
0.45	1.16	1.20	0.71
0.50	1.10	1.30	0.68
0.55	1.04	1.40	0.66
0.60	1.00	1.50	0.63
0.65	0.96	1.60	0.61
0.70	0.93	1.70	0.59
0.75	0.90	1.80	0.58
0.80	0.87	1.90	0.56
0.85	0.84	2.00	0.55
0.90	0.82	2.10	0.54

A.2.5 Higher pressure natural gas tables. Capacities for gas at pressures of 2.0 psig (13.8 kPa) or greater in cubic feet per hour of 0.60 *specific gravity* gas for different sizes and lengths are shown in Table G2413.4(2) for iron *pipe* or equivalent rigid *pipe*, Table G2413.4(4) for semi-rigid *tubing*, Table G2413.4(6) for corrugated stainless steel *tubing* and Table G2413.4(8) for polyethylene plastic *pipe*.

A.3 Use of capacity tables

A.3.1 Longest length method. This sizing method is conservative in its approach by applying the maximum operating conditions in the system as the norm for the system and by setting the length of *pipe* used to size any given part of the *pipng* system to the maximum value.

To determine the size of each section of *gas pipng* in a system within the range of the capacity tables, proceed as follows. (also see sample calculations included in this Appendix).

- (1) Divide the *pipng system* into appropriate segments consistent with the presence of tees, branch lines and main runs. For each segment, determine the gas load (assuming all *appliances* operate simultaneously) and its overall length. An allowance (in equivalent length of *pipe*) as determined from Table A.2.2 shall be considered for *pipng* segments that include four or more fittings.
- (2) Determine the gas *demand* of each *appliance* to be attached to the *pipng system*. Where Tables G2413.4(1) through G2413.4(8) are to be used to select the *pipng* size, calculate the gas *demand* in terms of cubic feet per hour for each *pipng system outlet*.
- (3) Where the *pipng system* is for use with other than undiluted liquefied petroleum gases, determine the design system pressure, the allowable loss in pressure (*pressure drop*), and *specific gravity* of the gas to be used in the *pipng system*.

- (4) Determine the length of *pipng* from the point of delivery to the most remote *outlet* in the building/*pipng system*.
- (5) In the appropriate capacity table, select the row showing the measured length or the next longer length if the table does not give the exact length. This is the only length used in determining the size of any section of *gas pipng*. If the gravity factor is to be applied, the values in the selected row of the table are multiplied by the appropriate multiplier from Table A.2.4.
- (6) Use this horizontal row to locate ALL gas *demand* figures for this particular system of *pipng*.
- (7) Starting at the most remote *outlet*, find the gas *demand* for that *outlet* in the horizontal row just selected. If the exact figure of *demand* is not shown, choose the next larger figure left in the row.
- (8) Opposite this *demand* figure, in the first row at the top, the correct size of *gas pipng* will be found.
- (9) Proceed in a similar manner for each *outlet* and each section of *gas pipng*. For each section of *pipng*, determine the total gas *demand* supplied by that section.

When a large number of *pipng* components (such as elbows, tees and *valves*) are installed in a *pipe* run, additional pressure loss can be accounted for by the use of equivalent lengths. Pressure loss across any *pipng* component can be equated to the *pressure drop* through a length of *pipe*. The equivalent length of a combination of only four elbows/tees can result in a jump to the next larger length row, resulting in a significant reduction in capacity. The equivalent lengths in feet shown in Table A.2.2 have been computed on a basis that the inside diameter corresponds to that of Schedule 40 (standard-weight) steel *pipe*, which is close enough for most purposes involving other schedules of *pipe*. Where a more specific solution for equivalent length is desired, this may be made by multiplying the actual inside diameter of the *pipe* in inches by $n/12$, or the actual inside diameter in feet by n (n can be read from the table heading). The equivalent length values can be used with reasonable accuracy for copper or brass fittings and bends although the resistance per foot of copper or brass *pipe* is less than that of steel. For copper or brass *valves*, however, the equivalent length of *pipe* should be taken as 45 percent longer than the values in the table, which are for steel *pipe*.

A.3.2 Branch length method. This sizing method reduces the amount of conservatism built into the traditional Longest Length Method. The longest length as measured from the *meter* to the furthest remote *appliance* is only used to size the initial parts of the overall *pipng system*. The Branch Length Method is applied in the following manner:

- (1) Determine the gas load for each of the connected *appliances*.
- (2) Starting from the *meter*, divide the *pipng system* into a number of connected segments, and determine the length and amount of gas that each segment would carry assuming that all *appliances* were operated simultaneously. An allowance (in equivalent length of *pipe*) as determined from Table A.2.2

should be considered for *pip*ing segments that include four or more fittings.

- (3) Determine the distance from the outlet of the gas *meter* to the *appliance* furthest removed from the *meter*.
- (4) Using the longest distance (found in Step 3), size each *pip*ing segment from the *meter* to the most remote *appliance outlet*.
- (5) For each of these *pip*ing segments, use the longest length and the calculated gas load for all of the connected *appliances* for the segment and begin the sizing process in Steps 6 through 8.
- (6) Referring to the appropriate sizing table (based on operating conditions and *pip*ing material), find the longest length distance in the first column or the next larger distance if the exact distance is not listed. The use of alternative operating pressures and/or *pressure drops* will require the use of a different sizing table, but will not alter the sizing methodology. In many cases, the use of alternative operating pressures and/or *pressure drops* will require the approval of both the *code official* and the local gas serving utility.
- (7) Trace across this row until the gas load is found or the closest larger capacity if the exact capacity is not listed.
- (8) Read up the table column and select the appropriate *pipe* size in the top row. Repeat Steps 6, 7 and 8 for each *pipe* segment in the longest run.
- (9) Size each remaining section of branch *pip*ing not previously sized by measuring the distance from the gas *meter* location to the most remote *outlet* in that branch, using the gas load of attached *appliances* and following the procedures of Steps 2 through 8.

A.3.3 Hybrid pressure method. The sizing of a 2 psi (13.8 kPa) gas *pip*ing system is performed using the traditional Longest Length Method but with modifications. The 2 psi (13.8 kPa) system consists of two independent pressure zones, and each zone is sized separately. The Hybrid Pressure Method is applied as follows.

The sizing of the 2 psi (13.8 kPa) section (from the *meter* to the line *regulator*) is as follows:

- (1) Calculate the gas load (by adding up the name plate ratings) from all connected *appliances*. (In certain circumstances the installed gas load may be increased up to 50 percent to accommodate future addition of *appliances*.) Ensure that the line *regulator* capacity is adequate for the calculated gas load and that the required *pressure drop* (across the *regulator*) for that capacity does not exceed $\frac{3}{4}$ psi (5.2 kPa) for a 2 psi (13.8 kPa) system. If the *pressure drop* across the *regulator* is too high (for the connected gas load), select a larger *regulator*.
- (2) Measure the distance from the *meter* to the line *regulator* located inside the building.
- (3) If there are multiple line *regulators*, measure the distance from the *meter* to the *regulator* furthest removed from the *meter*.

- (4) The maximum allowable *pressure drop* for the 2 psi (13.8 kPa) section is 1 psi (6.9 kPa).
- (5) Referring to the appropriate sizing table (based on *pip*ing material) for 2 psi (13.8 kPa) systems with a 1 psi (6.9 kPa) *pressure drop*, find this distance in the first column, or the closest larger distance if the exact distance is not listed.
- (6) Trace across this row until the gas load is found or the closest larger capacity if the exact capacity is not listed.
- (7) Read up the table column to the top row and select the appropriate *pipe* size.
- (8) If there are multiple *regulators* in this portion of the *pip*ing system, each line segment must be sized for its actual gas load, but using the longest length previously determined above.

The low pressure section (all *pip*ing downstream of the line *regulator*) is sized as follows:

- (1) Determine the gas load for each of the connected *appliances*.
- (2) Starting from the line *regulator*, divide the *pip*ing system into a number of connected segments and/or independent parallel *pip*ing segments, and determine the amount of gas that each segment would carry assuming that all *appliances* were operated simultaneously. An allowance (in equivalent length of *pipe*) as determined from Table A.2.2 should be considered for *pip*ing segments that include four or more fittings.
- (3) For each *pip*ing segment, use the actual length or longest length (if there are sub-branchlines) and the calculated gas load for that segment and begin the sizing process as follows:
 - (a) Referring to the appropriate sizing table (based on operating pressure and *pip*ing material), find the longest length distance in the first column or the closest larger distance if the exact distance is not listed. The use of alternative operating pressures and/or *pressure drops* will require the use of a different sizing table, but will not alter the sizing methodology. In many cases, the use of alternative operating pressures and/or *pressure drops* may require the approval of the *code official*.
 - (b) Trace across this row until the *appliance* gas load is found or the closest larger capacity if the exact capacity is not listed.
 - (c) Read up the table column to the top row and select the appropriate *pipe* size.
 - (d) Repeat this process for each segment of the *pip*ing system.

A.3.4 Pressure drop per 100 feet method. This sizing method is less conservative than the others, but it allows the designer to immediately see where the largest *pressure drop* occurs in the system. With this information, modifications can be made to bring the total drop to the critical *appliance* within the limitations that are presented to the designer.

APPENDIX A

Follow the procedures described in the Longest Length Method for Steps (1) through (4) and (9).

For each *pipng* segment, calculate the *pressure drop* based on *pipe* size, length as a percentage of 100 feet (30 480 mm), and gas flow. Table A.3.4 shows *pressure drop* per 100 feet (30 480 mm) for *pipe* sizes from 1/2 inch (12.7 mm) through 2 inch (51 mm). The sum of *pressure drops* to the critical *appliance* is subtracted from the supply pressure to verify that sufficient pressure will be available. If not, the layout can be examined to find the high drop section(s) and sizing selections modified.

Note: Other values can be obtained by using the following equation:

$$\text{Desired Value} = MBH \times \sqrt{\frac{\text{Desired Drop}}{\text{Table Drop}}}$$

For example, if it is desired to get flow through 3/4-inch (19.1 mm) *pipe* at 2 inches/100 feet, multiple the capacity of 3/4-inch *pipe* at 1 inch/100 feet by the square root of the pressure ratio:

$$147 MBH \times \sqrt{\frac{2'' \text{ w.c.}}{1'' \text{ w.c.}}} = 147 \times 1.414 = 208 MBH$$

(MBH = 1000 Btu/h)

A.4 Use of sizing equations. Capacities of smooth wall *pipe* or *tubing* can also be determined by using the following formulae:

(1) High Pressure [1.5 psi (10.3 kPa) and above]:

$$Q = 181.6 \sqrt{\frac{D^5 \cdot (P_1^2 - P_2^2) \cdot Y}{C_r \cdot fba \cdot L}}$$

$$= 2237 D^{2.623} \left[\frac{(P_1^2 - P_2^2) \cdot Y}{C_r \cdot L} \right]^{0.541}$$

(2) Low Pressure [Less than 1.5 psi (10.3 kPa)]:

$$Q = 187.3 \sqrt{\frac{D^5 \cdot \Delta H}{C_r \cdot fba \cdot L}}$$

$$= 2313 D^{2.623} \left(\frac{\Delta H}{C_r \cdot L} \right)^{0.541}$$

where:

Q = Rate, cubic feet per hour at 60°F and 30-inch mercury column

D = Inside diameter of *pipe*, in.

*P*₁ = Upstream pressure, psia

*P*₂ = Downstream pressure, psia

Y = Superexpansibility factor = 1/supercompressibility factor

*C*_r = Factor for viscosity, density and temperature*

$$= 0.00354 ST \left(\frac{Z}{S} \right)^{0.152}$$

Note: See Table 402.4 for *Y* and *C*_r for natural gas and propane.

S = *Specific gravity* of gas at 60°F and 30-inch mercury column (0.60 for natural gas, 1.50 for propane), or = 1488μ

T = Absolute temperature, °F or = *t* + 460

t = Temperature, °F

Z = Viscosity of gas, centipoise (0.012 for natural gas, 0.008 for propane), or = 1488μ

fba = Base friction factor for air at 60°F (CF=1)

L = Length of *pipe*, ft

ΔH = *Pressure drop*, in. w.c. (27.7 in. H₂O = 1 psi)

(For SI, see Section G2413.4)

A.5 Pipe and tube diameters. Where the internal diameter is determined by the formulas in Section G2413.4, Tables A.5.1 and A.5.2 can be used to select the nominal or standard *pipe* size based on the calculated internal diameter.

TABLE A.3.4
THOUSANDS OF Btu/h (MBH) OF NATURAL GAS PER 100 FEET OF PIPE AT
VARIOUS PRESSURE DROPS AND PIPE DIAMETERS

PRESSURE DROP PER 100 FEET IN INCHES W.C.	PIPE SIZES (inch)					
	1/2	3/4	1	1 1/4	1 1/2	2
0.2	31	64	121	248	372	716
0.3	38	79	148	304	455	877
0.5	50	104	195	400	600	1160
1.0	71	147	276	566	848	1640

For SI: 1 inch = 25.4 mm, 1 foot = 304.8 mm.

TABLE A.5.1
SCHEDULE 40 STEEL PIPE STANDARD SIZES

NOMINAL SIZE (in.)	INTERNAL DIAMETER (in.)	NOMINAL SIZE (in.)	INTERNAL DIAMETER (in.)
1/4	0.364	1 1/2	1.610
3/8	0.493	2	2.067
1/2	0.622	2 1/2	2.469
3/4	0.824	3	3.068
1	1.049	3 1/2	3.548
1 1/4	1.380	4	4.026

A.6 Use of sizing charts. A third method of sizing *gas piping* is detailed below as an option that is useful when large quantities of *piping* are involved in a job (e.g., an apartment house) and material costs are of concern. If the user is not completely familiar with this method, the resulting *pipe* sizing should be checked by a knowledgeable gas engineer. The sizing charts are applied as follows.

- (1) With the layout developed according to Section R106.1.1 of the *code*, indicate in each section the design gas flow under maximum operation conditions. For many layouts, the maximum design flow will be the sum of all connected loads. However, in some cases, certain combinations of *appliances* will not occur simultaneously (e.g., gas heating and air conditioning). For these cases, the design flow is the greatest gas flow that can occur at any one time.
- (2) Determine the inlet gas pressure for the system being designed. In most cases, the point of inlet will be the gas *meter* or service *regulator*, but in the case of a system addition, it could be the point of connection to the existing system.
- (3) Determine the minimum pressure required at the inlet to the critical *appliance*. Usually, the critical item will be the *appliance* with the highest required pressure for satisfactory operation. If several items have the same required pressure, it will be the one with the greatest length of *piping* from the system inlet.
- (4) The difference between the inlet pressure and critical item pressure is the allowable system *pressure drop*. Figures A.6(a) and A.6(b) show the relationship between gas flow, *pipe* size and *pipe* length for natural gas with 0.60 *specific gravity*.
- (5) To use Figure A.6(a) (low pressure applications), calculate the *piping* length from the inlet to the critical utilization *equipment*. Increase this length by 50 percent to allow for fittings. Divide the allowable *pressure drop* by the equivalent length (in hundreds of feet) to determine the allowable *pressure drop* per hundred feet. Select the *pipe* size from Figure A.6(a) for the required volume of flow.
- (6) To use Figure A.6(b) (high pressure applications), calculate the equivalent length as above. Calculate the index number for Figure A.6(b) by dividing the difference between the squares of the absolute values of inlet and outlet pressures by the equivalent length (in hundreds of feet). Select the *pipe* size from Figure A.6(b) for the gas volume required.

TABLE A.5.2
COPPER TUBE STANDARD SIZES

TUBE TYPE	NOMINAL OR STANDARD SIZE (inches)	INTERNAL DIAMETER (inches)
K	1/4	0.305
L	1/4	0.315
ACR (D)	3/8	0.315
ACR (A)	3/8	0.311
K	3/8	0.402
L	3/8	0.430
ACR (D)	1/2	0.430
ACR (A)	1/2	0.436
K	1/2	0.527
L	1/2	0.545
ACR (D)	5/8	0.545
ACR (A)	5/8	0.555
K	5/8	0.652
L	5/8	0.666
ACR (D)	3/4	0.666
ACR (A)	3/4	0.680
K	3/4	0.745
L	3/4	0.785
ACR	7/8	0.785
K	1	0.995
L	1	1.025
ACR	1 1/8	1.025
K	1 1/4	1.245
L	1 1/4	1.265
ACR	1 3/8	1.265
K	1 1/2	1.481
L	1 1/2	1.505
ACR	1 5/8	1.505
K	2	1.959
L	2	1.985
ACR	2 1/8	1.985
K	2 1/2	2.435
L	2 1/2	2.465
ACR	2 5/8	2.465
K	3	2.907
L	3	2.945
ACR	3 1/8	2.945

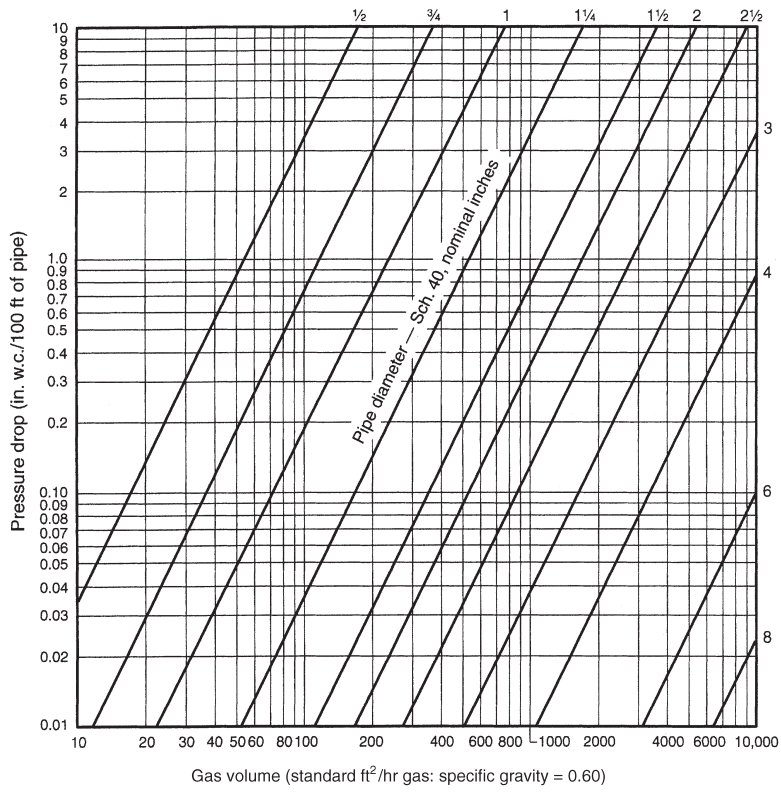

FIGURE A.6(a)
CAPACITY OF NATURAL GAS PIPING, LOW PRESSURE (0.60 WC)

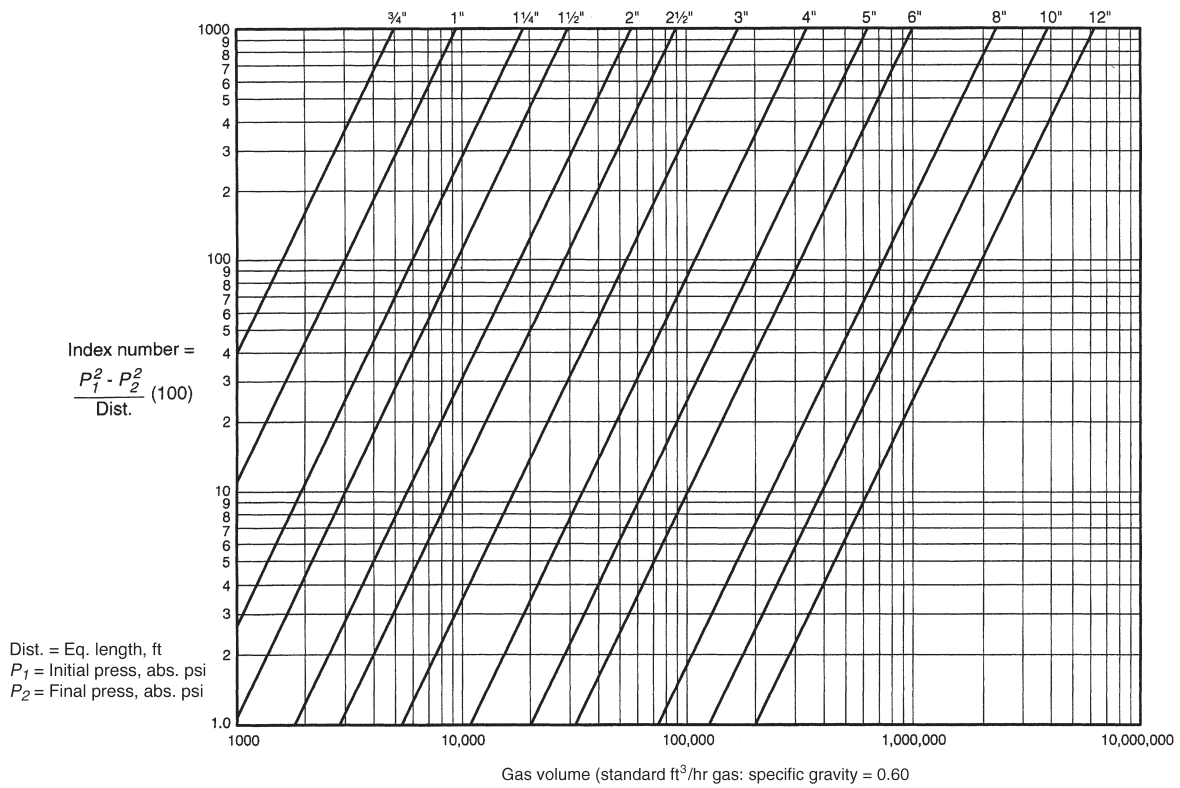
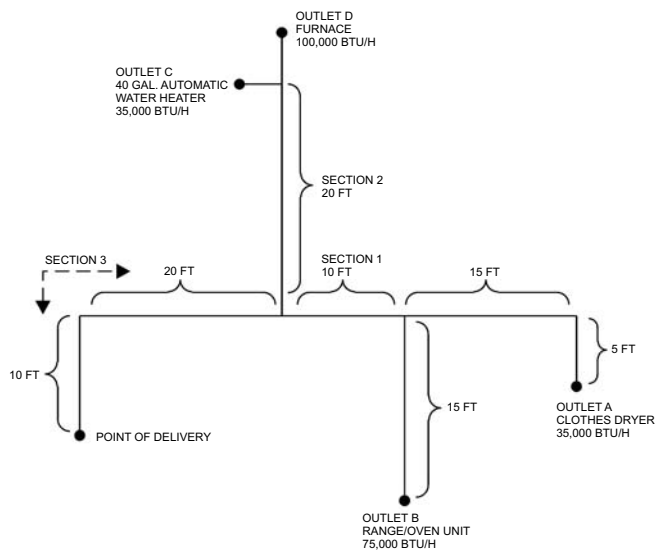

FIGURE A.6 (b)
CAPACITY OF NATURAL GAS PIPING, HIGH PRESSURE (1.5 psi and above)

A.7 Examples of piping system design and sizing

A.7.1 Example 1: Longest length method. Determine the required *pipe* size of each section and *outlet* of the *piping system* shown in Figure A.7.1, with a designated *pressure drop* of 0.5-inch w.c. (125 Pa) using the Longest Length Method. The gas to be used has 0.60 *specific gravity* and a heating value of 1,000 *Btu/ft³* (37.5 MJ/m³).



**FIGURE A.7.1
PIPING PLAN SHOWING A STEEL PIPING SYSTEM**

Solution:

(1) Maximum gas demand for Outlet A:

$$\frac{\text{Consumption (rating plate input, or Table G2413.2 if necessary)}}{\text{Btu of gas}} = \frac{35,000 \text{ Btu per hour rating}}{1,000 \text{ Btu per cubic foot}} = 35 \text{ cubic feet per hour} = 35 \text{ cfh}$$

Maximum gas demand for Outlet B:

$$\frac{\text{Consumption}}{\text{Btu of gas}} = \frac{75,000}{1,000} = 75 \text{ cfh}$$

Maximum gas demand for Outlet C:

$$\frac{\text{Consumption}}{\text{Btu of gas}} = \frac{35,000}{1,000} = 35 \text{ cfh}$$

Maximum gas demand for Outlet D:

$$\frac{\text{Consumption}}{\text{Btu of gas}} = \frac{100,000}{1,000} = 100 \text{ cfh}$$

(2) The length of *pipe* from the point of delivery to the most remote *outlet* (A) is 60 feet (18 288 mm). This is the only distance used.

(3) Using the row marked 60 feet (18 288 mm) in Table G2413.4(1):

(a) *Outlet* A, supplying 35 cfh (0.99 m³/hr), requires ³/₈-inch *pipe*.

(b) *Outlet* B, supplying 75 cfh (2.12 m³/hr), requires ³/₄-inch *pipe*.

(c) Section 1, supplying *Outlets* A and B, or 110 cfh (3.11 m³/hr), requires ³/₄-inch *pipe*.

(d) Section 2, supplying *Outlets* C and D, or 135 cfh (3.82 m³/hr), requires ³/₄-inch *pipe*.

(e) Section 3, supplying *Outlets* A, B, C and D, or 245 cfh (6.94 m³/hr), requires 1-inch *pipe*.

(4) If a different gravity factor is applied to this example, the values in the row marked 60 feet (18 288 mm) of Table G2413.4(1) would be multiplied by the appropriate multiplier from Table A.2.4 and the resulting cubic feet per hour values would be used to size the *pipe*.

Section A.7.2 through A7.4 note: These examples are based on tables found in the International Fuel Gas Code.

A.7.2 Example 2: Hybrid or dual pressure systems.

Determine the required CSST size of each section of the *piping system* shown in Figure A.7.2, with a designated *pressure drop* of 1 psi (6.9 kPa) for the 2 psi (13.8 kPa) section and 3-inch w.c. (0.75 kPa) *pressure drop* for the 13-inch w.c. (2.49 kPa) section. The gas to be used has 0.60 *specific gravity* and a heating value of 1,000 *Btu/ft³* (37.5 MJ/m³).

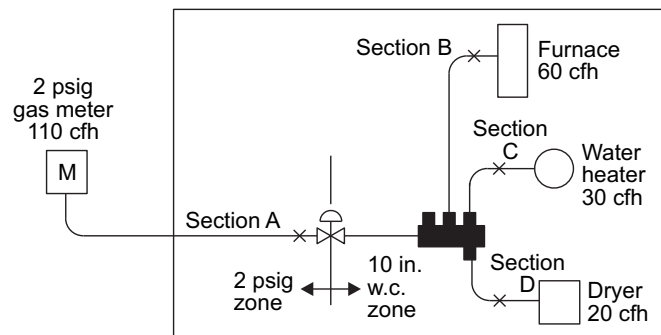

- Length of runs:
 A = 100 ft
 B = 15 ft
 C = 10 ft
 D = 25 ft
- Key:
 Manifold
 Shut-off valve
 Pressure regulator
 Gas meter

**FIGURE A.7.2
PIPING PLAN SHOWING A CSST SYSTEM**

Solution

(1) Size 2 psi (13.8 kPa) line using Table 402.4(16).

(2) Size 10-inch w.c. (2.5 kPa) lines using Table 402.4(14).

(3) Using the following, determine if sizing tables can be used.

(a) Total gas load shown in Figure A.7.2 equals 110 cfh (3.11 m³/hr).

(b) Determine *pressure drop* across *regulator* [see notes in Table 402.4 (16)].

- (c) If *pressure drop* across *regulator* exceeds $\frac{3}{4}$ psig (5.2 kPa), Table 402.4 (16) cannot be used. Note: If *pressure drop* exceeds $\frac{3}{4}$ psi (5.2 kPa), then a larger *regulator* must be selected or an alternative sizing method must be used.
 - (d) *Pressure drop* across the line *regulator* [for 110 cfh (3.11 m³/hr)] is 4-inch w.c. (0.99 kPa) based on manufacturer's performance data.
 - (e) Assume the CSST manufacturer has *tubing* sizes or EHDs of 13, 18, 23 and 30.
- (4) Section A [2 psi (13.8 kPa) zone]
- (a) Distance from *meter* to *regulator* = 100 feet (30 480 mm).
 - (b) Total load supplied by A = 110 cfh (3.11 m³/hr) (*furnace* + *water heater* + *dryer*).
 - (c) Table 402.4 (16) shows that EHD size 18 should be used.
- Note: It is not unusual to oversize the supply line by 25 to 50 percent of the as-installed load. EHD size 18 has a capacity of 189 cfh (5.35 m³/hr).
- (5) Section B (low pressure zone)
- (a) Distance from *regulator* to *furnace* is 15 feet (4572 mm).
 - (b) Load is 60 cfh (1.70 m³/hr).
 - (c) Table 402.4 (14) shows that EHD size 13 should be used.
- (6) Section C (low pressure zone)
- (a) Distance from *regulator* to *water heater* is 10 feet (3048 mm).
 - (b) Load is 30 cfh (0.85 m³/hr).
 - (c) Table 402.4 (14) shows that EHD size 13 should be used.
- (7) Section D (low pressure zone)
- (a) Distance from *regulator* to *dryer* is 25 feet (7620 mm).
 - (b) Load is 20 cfh (0.57 m³/hr).
 - (c) Table 402.4(14) shows that EHD size 13 should be used.

A.7.3 Example 3: Branch length method. Determine the required semi-rigid copper *tubing* size of each section of the *pipng system* shown in Figure A.7.3, with a designated *pressure drop* of 1-inch w.c. (250 Pa) (using the Branch Length Method). The gas to be used has 0.60 *specific gravity* and a heating value of 1,000 *Btu/ft³* (37.5 MJ/m³).



Solution

- (1) Section A
- (a) The length of *tubing* from the point of delivery to the most remote *appliance* is 50 feet (15 240 mm), A + C.

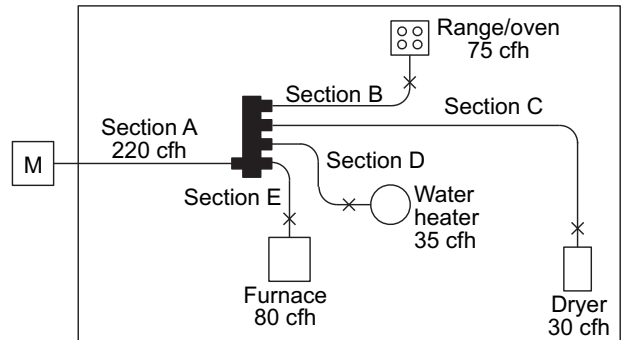
- (b) Use this longest length to size Sections A and C.
 - (c) Using the row marked 50 feet (15 240 mm) in Table 402.4(8), Section A, supplying 220 cfh (6.2 m³/hr) for four *appliances* requires 1-inch *tubing*.
- (2) Section B
- (a) The length of *tubing* from the point of delivery to the range/oven at the end of Section B is 30 feet (9144 mm), A + B.
 - (b) Use this branch length to size Section B only.
 - (c) Using the row marked 30 feet (9144 mm) in Table 402.4(8), Section B, supplying 75 cfh (2.12 m³/hr) for the range/oven requires $\frac{1}{2}$ -inch *tubing*.
- (3) Section C
- (a) The length of *tubing* from the point of delivery to the dryer at the end of Section C is 50 feet (15 240 mm), A + C.
 - (b) Use this branch length (which is also the longest length) to size Section C.
 - (c) Using the row marked 50 feet (15 240 mm) in Table 402.4(8), Section C, supplying 30 cfh (0.85 m³/hr) for the dryer requires $\frac{3}{8}$ -inch *tubing*.
- (4) Section D
- (a) The length of *tubing* from the point of delivery to the *water heater* at the end of Section D is 30 feet (9144 mm), A + D.
 - (b) Use this branch length to size Section D only.
 - (c) Using the row marked 30 feet (9144 mm) in Table 402.4(8), Section D, supplying 35 cfh (0.99 m³/hr) for the *water heater* requires $\frac{3}{8}$ -inch *tubing*.



Length of runs:
 A = 20 ft
 B = 10 ft
 C = 30 ft
 D = 10 ft
 E = 10 ft

Key:
 Manifold
 Shut-off valve
 Gas meter

Total gas load = 220 cfh

FIGURE A.7.3
PIPING PLAN SHOWING A COPPER TUBING SYSTEM

- (5) Section E
- The length of *tubing* from the point of delivery to the *furnace* at the end of Section E is 30 feet (9144 mm), A + E.
 - Use this branch length to size Section E only.
 - Using the row marked 30 feet (9144 mm) in Table 402.4(8), Section E, supplying 80 cfh (2.26 m³/hr) for the *furnace* requires 1/2-inch *tubing*.

A.7.4 Example 4: Modification to existing piping system. Determine the required CSST size for Section G (retrofit application) of the *piping system* shown in Figure A.7.4, with a designated *pressure drop* of 0.5-inch w.c. (125 Pa) using the branch length method. The gas to be used has 0.60 *specific gravity* and a heating value of 1,000 *Btu/ft³* (37.5 MJ/m³).

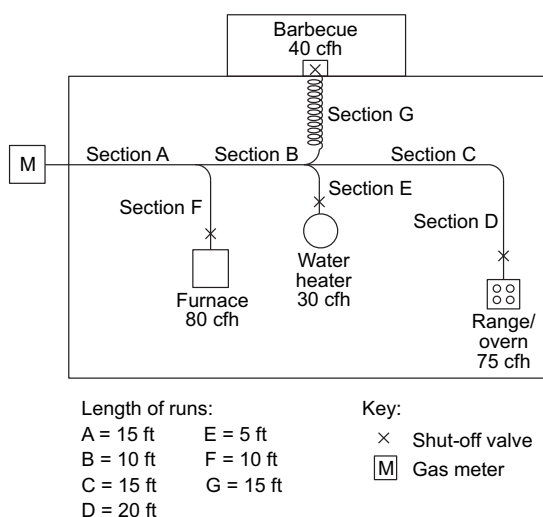

FIGURE A.7.4
PIPING PLAN SHOWING A MODIFICATION
TO EXISTING PIPING SYSTEM

Solution

- The length of *pipe* and CSST from the point of delivery to the retrofit *appliance* (barbecue) at the end of Section G is 40 feet (12 192 mm), A + B + G.
- Use this branch length to size Section G.
- Assume the CSST manufacturer has *tubing* sizes or EHDs of 13, 18, 23 and 30.
- Using the row marked 40 feet (12 192 mm) in Table 402.4(13), Section G, supplying 40 cfh (1.13 m³/hr) for the barbecue requires EHD 18 CSST.
- The sizing of Sections A, B, F and E must be checked to ensure adequate gas carrying capacity since an *appliance* has been added to the *piping system* (see A.7.1 for details).

A.7.5 Example 5: Calculating pressure drops due to temperature changes. A test *piping system* is installed on a warm autumn afternoon when the temperature is 70°F (21°C). In accordance with local custom, the new *piping system* is subjected to an air *pressure test* at 20 psig (138 kPa). Overnight, the temperature drops and when the

inspector shows up first thing in the morning the temperature is 40°F (4°C).

If the volume of the *piping system* is unchanged, then the formula based on Boyle's and Charles' law for determining the new pressure at a reduced temperature is as follows:

$$\frac{T_1}{T_2} = \frac{P_1}{P_2}$$

where:

T_1 = Initial temperature, absolute ($T_1 + 459$)

T_2 = Final temperature, absolute ($T_2 + 459$)

P_1 = Initial pressure, psia ($P_1 + 14.7$)

P_2 = Final pressure, psia ($P_2 + 14.7$)

$$\frac{(70 + 459)}{(40 + 459)} = \frac{(20 + 14.7)}{(P_2 + 14.7)}$$

$$\frac{529}{499} = \frac{34.7}{(P_2 + 14.7)}$$

$$(P_2 + 14.7) \times \frac{529}{499} = 34.7$$

$$(P_2 + 14.7) = \frac{34.7}{1.060}$$

$$P_2 = 32.7 - 14.7$$

$$P_2 = 18 \text{ psig}$$

Therefore, the gauge could be expected to register 18 psig (124 kPa) when the ambient temperature is 40°F (4°C).

A.7.6 Example 6: Pressure drop per 100 feet of pipe method.

Using the layout shown in Figure A.7.1 and $\Delta H = \text{pressure drop}$, in w.c. (27.7 in. H₂O = 1 psi), proceed as follows:

- Length to A = 20 feet, with 35,000 *Btu/hr*.

For 1/2-inch *pipe*, $\Delta H = \frac{20 \text{ feet}}{100 \text{ feet}} \times 0.3 \text{ inch w.c.} = 0.06 \text{ in. w.c.}$

- Length to B = 15 feet, with 75,000 *Btu/hr*.

For 3/4-inch *pipe*, $\Delta H = \frac{15 \text{ feet}}{100 \text{ feet}} \times 0.3 \text{ inch w.c.} = 0.045 \text{ in. w.c.}$

- Section 1 = 10 feet, with 110,000 *Btu/hr*. Here there is a choice:

For 1 inch *pipe*: $\Delta H = \frac{10 \text{ feet}}{100 \text{ feet}} \times 0.2 \text{ inch w.c.} = 0.02 \text{ in. w.c.}$

For 3/4-inch *pipe*: $\Delta H = \frac{10 \text{ feet}}{100 \text{ feet}} \times [0.5 \text{ inch w.c.} + \frac{(110,000 \text{ Btu/hr} - 104,000 \text{ Btu/hr})}{(147,000 \text{ Btu/hr} - 104,000 \text{ Btu/hr})} \times (1.0 \text{ inches w.c.} - 0.5 \text{ inch w.c.})] = 0.1 \times 0.57 \text{ inch w.c.} = 0.06 \text{ inch w.c.}$

Note that the pressure drop between 104,000 *Btu/hr* and 147,000 *Btu/hr* has been interpolated as 110,000 *Btu/hr*.

- Section 2 = 20 feet, with 135,000 *Btu/hr*. Here there is a choice:

For 1-inch pipe: $\Delta H = \frac{20 \text{ feet}}{100 \text{ feet}} \times [0.2 \text{ inch w.c.} + \frac{(14,000 \text{ Btu/hr})}{(27,000 \text{ Btu/hr})} \times 0.1 \text{ inch w.c.}] = 0.05 \text{ inch w.c.}]$

For $\frac{3}{4}$ -inch pipe: $\Delta H = \frac{20 \text{ feet}}{100 \text{ feet}} \times 1.0 \text{ inch w.c.} = 0.2 \text{ inch w.c.}]$

Note that the pressure drop between 121,000 Btu/hr and 148,000 Btu/hr has been interpolated as 135,000 Btu/hr, but interpolation for the $\frac{3}{4}$ -inch pipe (trivial for 104,000 Btu/hr to 147,000 Btu/hr) was not used.

- (5) Section 3 = 30 feet, with 245,000 Btu/hr. Here there is a choice:

For 1-inch pipe: $\Delta H = \frac{30 \text{ feet}}{100 \text{ feet}} \times 1.0 \text{ inches w.c.} = 0.3 \text{ inch w.c.}$

For $1\frac{1}{4}$ -inch pipe: $\Delta H = \frac{30 \text{ feet}}{100 \text{ feet}} \times 0.2 \text{ inch w.c.} = 0.06 \text{ inch w.c.}$

Note that interpolation for these options is ignored since the table values are close to the 245,000 Btu/hr carried by that section.

- (6) The total pressure drop is the sum of the section approaching A, Sections 1 and 3, or either of the following, depending on whether an absolute minimum is needed or the larger drop can be accommodated.

Minimum pressure drop to farthest appliance:

$\Delta H = 0.06 \text{ inch w.c.} + 0.02 \text{ inch w.c.} + 0.06 \text{ inch w.c.} = 0.14 \text{ inch w.c.}$

Larger pressure drop to the farthest appliance:

$\Delta H = 0.06 \text{ inch w.c.} + 0.06 \text{ inch w.c.} + 0.3 \text{ inch w.c.} = 0.42 \text{ inch w.c.}$

Notice that Section 2 and the run to B do not enter into this calculation, provided that the appliances have similar input pressure requirements.

For SI units: 1 Btu/hr = 0.293 W, 1 cubic foot = 0.028 m³, 1 foot = 0.305 m, 1 inch w.c. = 249 Pa.

APPENDIX B

SIZING OF VENTING SYSTEMS SERVING APPLIANCES EQUIPPED WITH DRAFT HOODS, CATEGORY I APPLIANCES, AND APPLIANCES LISTED FOR USE WITH TYPE B VENTS (Not Adopted by the State of Oregon)

(This appendix is informative and is not part of the *code*. This appendix is an excerpt from the 2009 *International Fuel Gas Code*, coordinated with the section numbering of the *International Residential Code*.)

EXAMPLES USING SINGLE APPLIANCE VENTING TABLES

Example 1: Single draft-hood-equipped appliance.

An installer has a 120,000 British thermal unit (*Btu*) per hour input appliance with a 5-inch-diameter *draft hood* outlet that needs to be vented into a 10-foot-high Type B *vent* system. What size vent should be used assuming (a) a 5-foot lateral single-wall metal *vent connector* is used with two 90-degree elbows, or (b) a 5-foot lateral single-wall metal *vent connector* is used with three 90-degree elbows in the vent system?

Solution:

Table G2428.2(2) should be used to solve this problem, because single-wall metal *vent connectors* are being used with a Type B *vent*.

- (a) Read down the first column in Table G2428.2(2) until the row associated with a 10-foot height and 5-foot lateral is found. Read across this row until a *vent* capacity

greater than 120,000 *Btu* per hour is located in the shaded columns labeled “NAT Max” for *draft-hood*-equipped appliances. In this case, a 5-inch-diameter *vent* has a capacity of 122,000 *Btu* per hour and may be used for this application.

- (b) If three 90-degree elbows are used in the vent system, then the maximum vent capacity listed in the tables must be reduced by 10 percent (see Section G2428.2.3 for single appliance vents). This implies that the 5-inch-diameter vent has an adjusted capacity of only 110,000 *Btu* per hour. In this case, the vent system must be increased to 6 inches in diameter (see calculations below).

$$122,000 (0.90) = 110,000 \text{ for 5-inch vent}$$

From Table G2428.2(2), Select 6-inch vent

$186,000 (0.90) = 167,000$; This is greater than the required 120,000. Therefore, use a 6-inch vent and connector where three elbows are used.

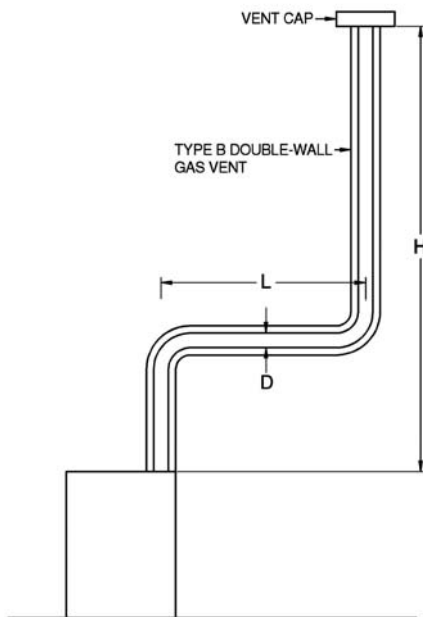

For SI: 1 foot = 304.8 mm, 1 British thermal unit per hour = 0.2931 W.
Table G2428.2(1) is used when sizing Type B double-wall gas vent connected directly to the appliance.

Note: The appliance may be either Category I draft hood equipped or fan-assisted type.

FIGURE B-1

TYPE B DOUBLE-WALL VENT SYSTEM SERVING A SINGLE APPLIANCE WITH A TYPE B DOUBLE-WALL VENT

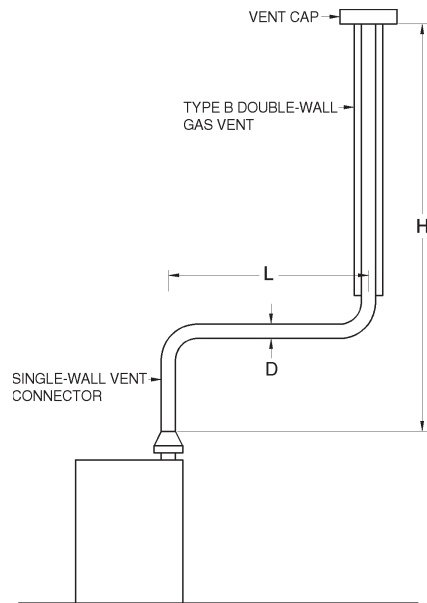

For SI: 1 foot = 304.8 mm, 1 British thermal unit per hour = 0.2931 W.

Table G2428.2(2) is used when sizing a single-wall metal vent connector attached to a Type B double-wall gas vent.

Note: The appliance may be either Category I draft hood equipped or fan-assisted type.

FIGURE B-2

TYPE B DOUBLE-WALL VENT SYSTEM SERVING A SINGLE APPLIANCE WITH A SINGLE-WALL METAL VENT CONNECTOR

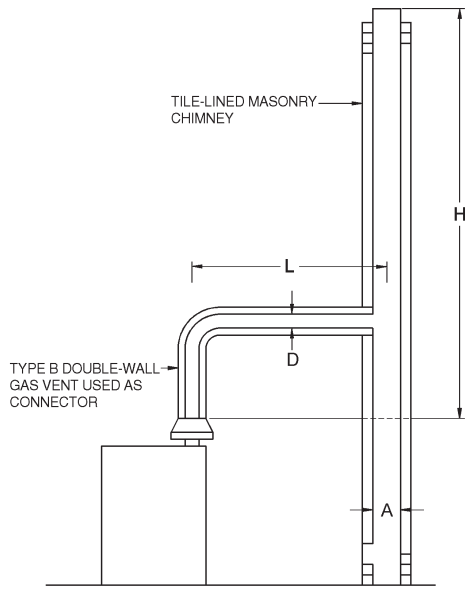
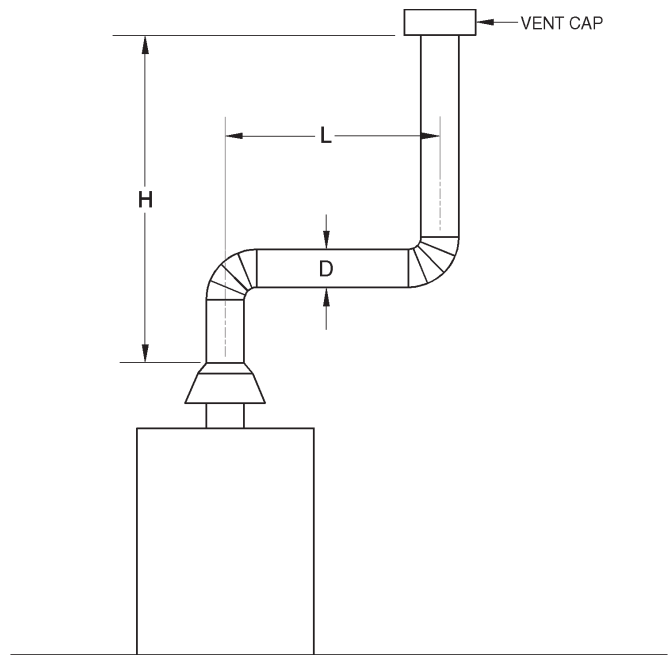

Table 504.2(3) of the *International Fuel Gas Code* is used when sizing a Type B double-wall gas vent connector attached to a tile-lined masonry chimney.

Note: "A" is the equivalent cross-sectional area of the tile liner.

Note: The appliance may be either Category I draft hood equipped or fan-assisted type.

FIGURE B-3
VENT SYSTEM SERVING A SINGLE APPLIANCE
WITH A MASONRY CHIMNEY OF TYPE B
DOUBLE-WALL VENT CONNECTOR



Asbestos cement Type B or single-wall metal vent serving a single draft-hood-equipped appliance [see Table 504.2(5) of the *International Fuel Gas Code*].

FIGURE B-5
ASBESTOS CEMENT TYPE B OR SINGLE-WALL
METAL VENT SYSTEM SERVING A SINGLE
DRAFT-HOOD-EQUIPPED APPLIANCE

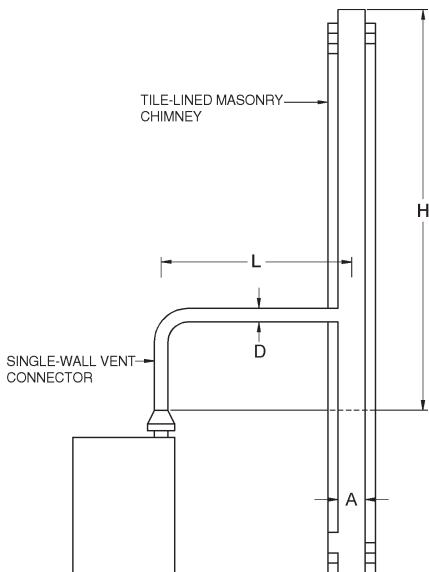

Table 504.2(4) of the *International Fuel Gas Code* is used when sizing a single-wall vent connector attached to a tile-lined masonry chimney.

Note: "A" is the equivalent cross-sectional area of the tile liner.

Note: The appliance may be either Category I draft hood equipped or fan-assisted type.

FIGURE B-4
VENT SYSTEM SERVING A SINGLE APPLIANCE
USING A MASONRY CHIMNEY AND A
SINGLE-WALL METAL VENT CONNECTOR

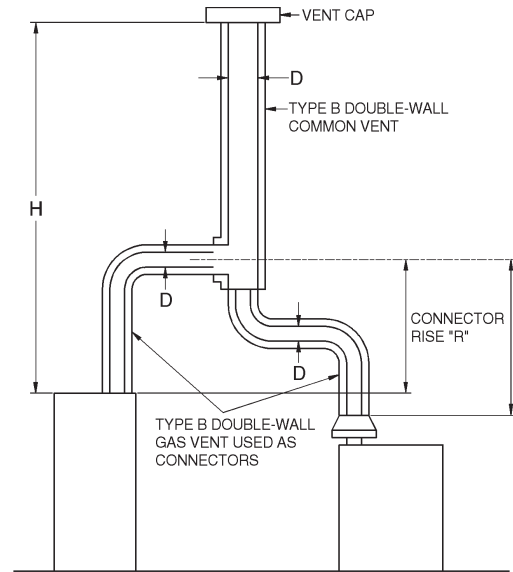

Table G2428.3(1) is used when sizing Type B double-wall vent connectors attached to a Type B double-wall common vent.

Note: Each appliance may be either Category I draft hood equipped or fan-assisted type.

FIGURE B-6
VENT SYSTEM SERVING TWO OR MORE APPLIANCES
WITH TYPE B DOUBLE-WALL VENT AND TYPE B
DOUBLE-WALL VENT CONNECTOR

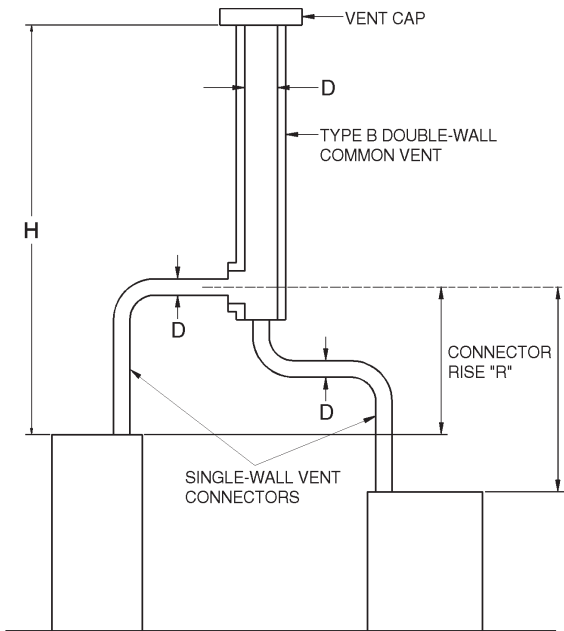

Table G2428.3(2) is used when sizing single-wall vent connectors attached to a Type B double-wall common vent.

Note: Each appliance may be either Category I draft hood equipped or fan-assisted type.

FIGURE B-7
VENT SYSTEM SERVING TWO OR MORE APPLIANCES
WITH TYPE B DOUBLE-WALL VENT AND
SINGLE-WALL METAL VENT CONNECTORS

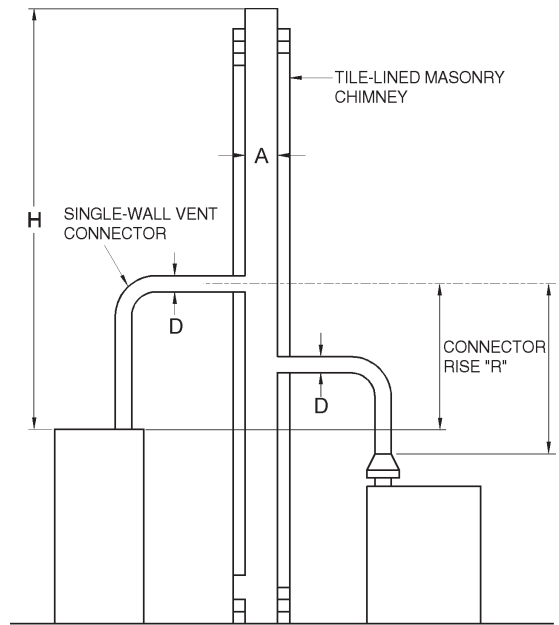

Table G2428.3(4) is used when sizing single-wall metal vent connectors attached to a tile-lined masonry chimney.

Note: "A" is the equivalent cross-sectional area of the tile liner.

Note: Each appliance may be either Category I draft hood equipped or fan-assisted type.

FIGURE B-9
MASONRY CHIMNEY SERVING TWO OR MORE APPLIANCES
WITH SINGLE-WALL METAL VENT CONNECTORS

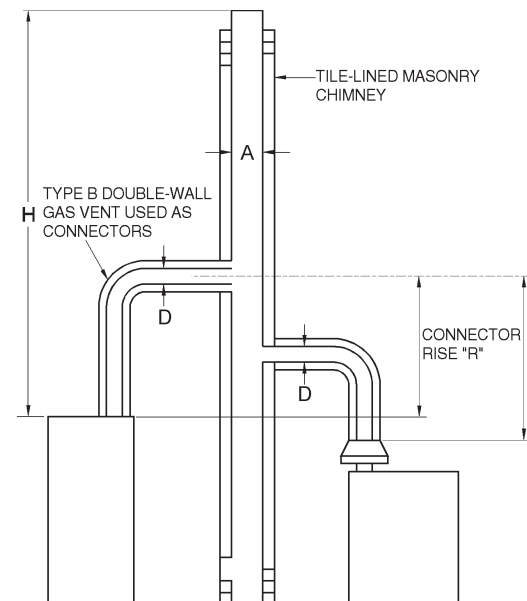
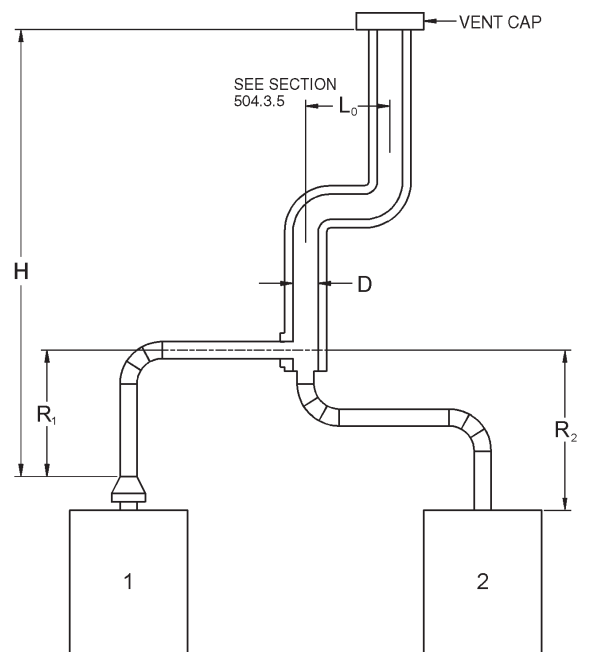

Table G2428.3(3) is used when sizing Type B double-wall vent connectors attached to a tile-lined masonry chimney.

Note: "A" is the equivalent cross-sectional area of the tile liner.

Note: Each appliance may be either Category I draft hood equipped or fan-assisted type.

FIGURE B-8
MASONRY CHIMNEY SERVING TWO OR MORE APPLIANCES
WITH TYPE B DOUBLE-WALL VENT CONNECTOR



Asbestos cement Type B or single-wall metal pipe vent serving two or more draft-hood-equipped appliances [see Table 504.3(5) of the *International Fuel Gas Code*].

FIGURE B-10
ASBESTOS CEMENT TYPE B OR SINGLE-WALL
METAL VENT SYSTEM SERVING TWO OR MORE
DRAFT-HOOD-EQUIPPED APPLIANCES

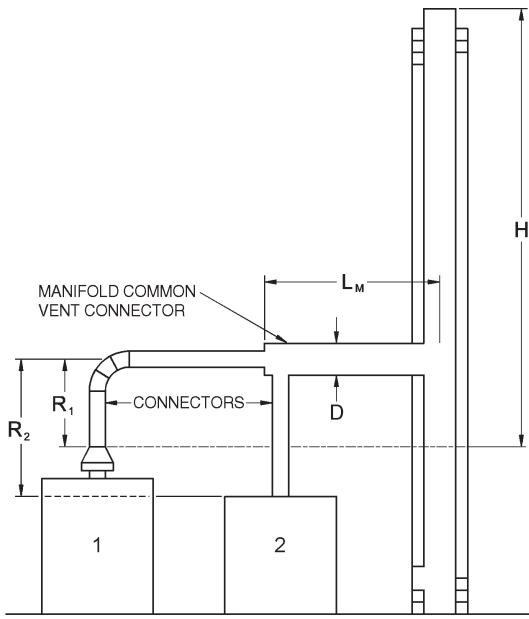

Example: Manifolded Common Vent Connector L_M shall be no greater than 18 times the common vent connector manifold inside diameter; i.e., a 4-inch (102 mm) inside diameter common vent connector manifold shall not exceed 72 inches (1829 mm) in length (see Section G2428.3.4).

Note: This is an illustration of a typical manifolded vent connector. Different appliance, vent connector, or common vent types are possible. Consult Section G2426.3.

**FIGURE B-11
USE OF MANIFOLD COMMON VENT CONNECTOR**

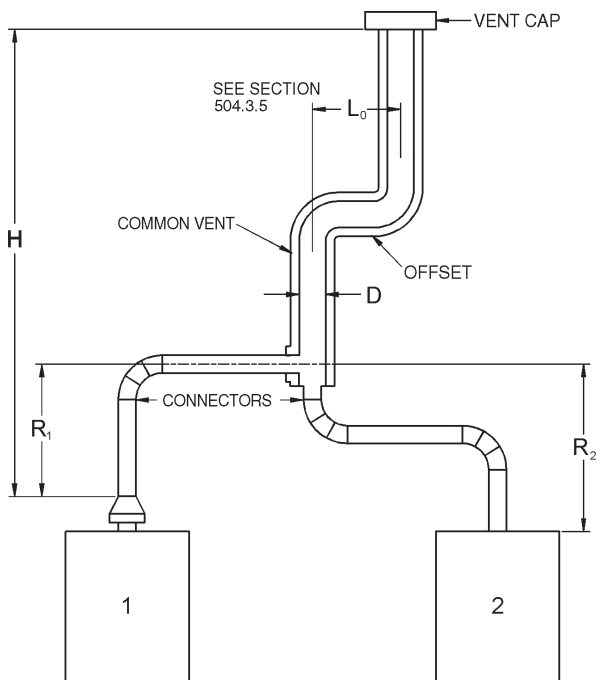

Example: Offset Common Vent

Note: This is an illustration of a typical offset vent. Different appliance, vent connector, or vent types are possible. Consult Sections G2428.2 and G2428.3.

**FIGURE B-12
USE OF OFFSET COMMON VENT**

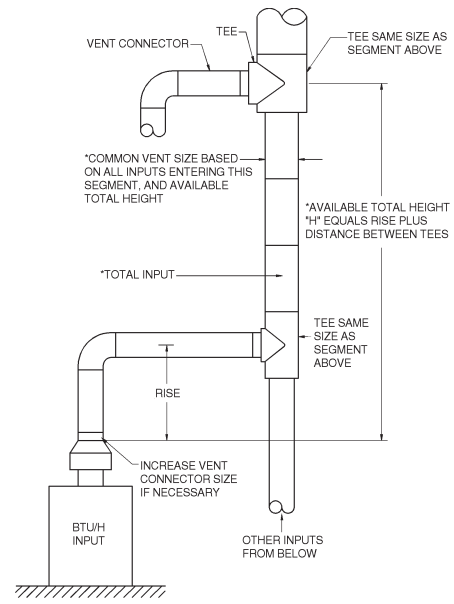

Vent connector size depends on:

- Combined inputs
- Rise
- Available total height "H"
- Table G2428.3(1) connectors

Common vent size depends on:

- Input
- Available total height "H"
- Table G2428.3(1) common vent

**FIGURE B-13
MULTISTORY GAS VENT DESIGN PROCEDURE
FOR EACH SEGMENT OF SYSTEM**

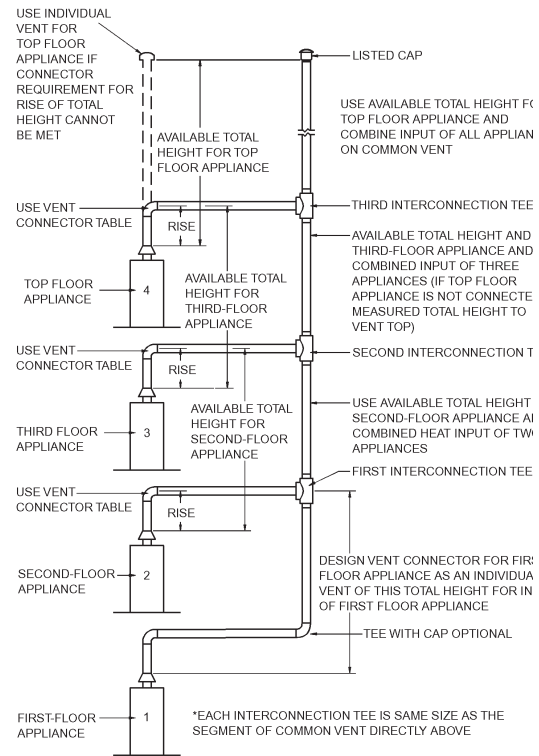

Principles of design of multistory vents using vent connector and common vent design tables (see Sections G2428.3.11 through G2428.3.13).

**FIGURE B-14
MULTISTORY VENT SYSTEMS**

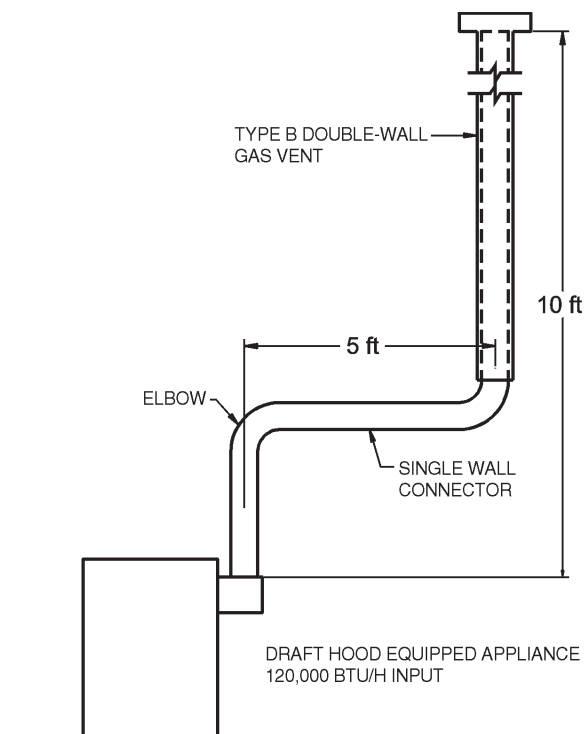

For SI: 1 foot = 304.8 mm, 1 British thermal unit per hour = 0.2931 W.

FIGURE B-15 (EXAMPLE 1)
SINGLE DRAFT-HOOD-EQUIPPED APPLIANCE

Example 2: Single fan-assisted appliance.

An installer has an 80,000 *Btu* per hour input fan-assisted appliance that must be installed using 10 feet of lateral connector attached to a 30-foot-high Type B vent. Two 90-degree elbows are needed for the installation. Can a single-wall metal vent connector be used for this application?

Solution:

Table G2428.2(2) refers to the use of single-wall metal vent connectors with Type B vent. In the first column find the row associated with a 30-foot height and a 10-foot lateral. Read across this row, looking at the FAN Min and FAN Max columns, to find that a 3-inch-diameter single-wall metal vent connector is not recommended. Moving to the next larger size single wall connector (4 inches), note that a 4-inch-diameter single-wall metal connector has a recommended minimum vent capacity of 91,000 *Btu* per hour and a recommended maximum vent capacity of 144,000 *Btu* per hour. The 80,000 *Btu* per hour fan-assisted appliance is outside this range, so the conclusion is that a single-wall metal vent connector cannot be used to vent this appliance using 10 feet of lateral for the connector.

However, if the 80,000 *Btu* per hour input appliance could be moved to within 5 feet of the vertical vent, then a 4-inch single-wall metal connector could be used to vent the appliance. Table G2428.2(2) shows the acceptable range of vent capacities for a 4-inch vent with 5 feet of lateral to be between 72,000 *Btu* per hour and 157,000 *Btu* per hour.

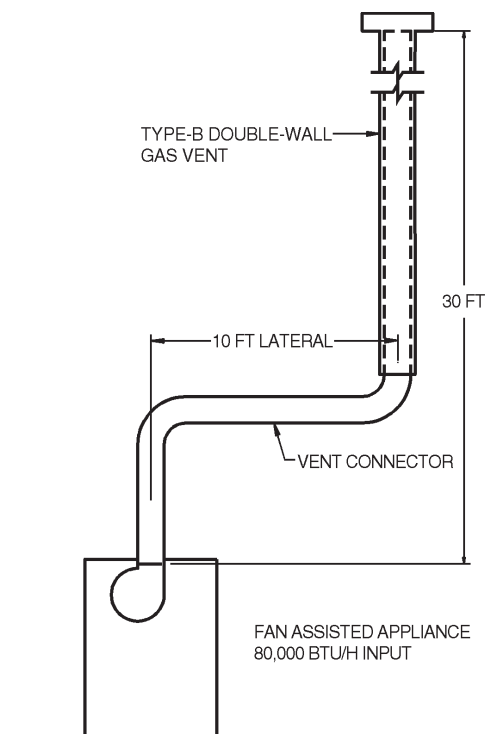

For SI: 1 foot = 304.8 mm, 1 British thermal unit per hour = 0.2931 W.

FIGURE B-16 (EXAMPLE 2)
SINGLE FAN-ASSISTED APPLIANCE

If the appliance cannot be moved closer to the vertical vent, then Type B vent could be used as the connector material. In this case, Table G2428.2(1) shows that for a 30-foot-high vent with 10 feet of lateral, the acceptable range of vent capacities for a 4-inch-diameter vent attached to a fan-assisted appliance is between 37,000 *Btu* per hour and 150,000 *Btu* per hour.

Example 3: Interpolating between table values.

An installer has an 80,000 *Btu* per hour input appliance with a 4-inch-diameter draft hood outlet that needs to be vented into a 12-foot-high Type B vent. The vent connector has a 5-foot lateral length and is also Type B. Can this appliance be vented using a 4-inch-diameter vent?

Solution:

Table G2428.2(1) is used in the case of an all Type B vent system. However, since there is no entry in Table G2428.2(1) for a height of 12 feet, interpolation must be used. Read down the 4-inch diameter NAT Max column to the row associated with 10-foot height and 5-foot lateral to find the capacity value of 77,000 *Btu* per hour. Read further down to the 15-foot height, 5-foot lateral row to find the capacity value of 87,000 *Btu* per hour. The difference between the 15-foot height capacity value and the 10-foot height capacity value is 10,000 *Btu* per hour. The capacity for a vent system with a 12-foot height is equal to the capacity for a 10-foot height plus $\frac{2}{5}$ of the difference between the 10-foot and 15-foot height values, or $77,000 + \frac{2}{5}(10,000) = 81,000$ *Btu* per hour. Therefore, a 4-inch-diameter vent may be used in the installation.

EXAMPLES USING COMMON VENTING TABLES

Example 4: Common venting two draft-hood-equipped appliances.

A 35,000 Btu per hour *water heater* is to be common vented with a 150,000 Btu per hour *furnace* using a common vent with a total height of 30 feet. The connector rise is 2 feet for the *water heater* with a horizontal length of 4 feet. The connector rise for the *furnace* is 3 feet with a horizontal length of 8 feet. Assume single-wall metal connectors will be used with Type B vent. What size connectors and combined vent should be used in this installation?

Solution:

Table G2428.3(2) should be used to size single-wall metal vent connectors attached to Type B vertical vents. In the vent connector capacity portion of Table G2428.3(2), find the row associated with a 30-foot vent height. For a 2-foot rise on the vent connector for the *water heater*, read the shaded columns for draft-hood-equipped appliances to find that a 3-inch-diameter vent connector has a capacity of 37,000 Btu per hour. Therefore, a 3-inch single-wall metal vent connector may be used with the *water heater*. For a draft-hood-equipped *furnace* with a 3-foot rise, read across the appropriate row to find that a 5-inch-diameter vent connector has a maximum capacity of 120,000 Btu per hour (which is too small for the *furnace*) and a 6-inch-diameter vent connector has a maximum vent capacity of 172,000 Btu per hour. Therefore, a 6-inch-diameter vent connector should be used with the 150,000 Btu per hour *furnace*. Since both vent connector horizontal lengths are less than the maximum lengths listed in Section G2428.3.2, the table values may be used without adjustments.

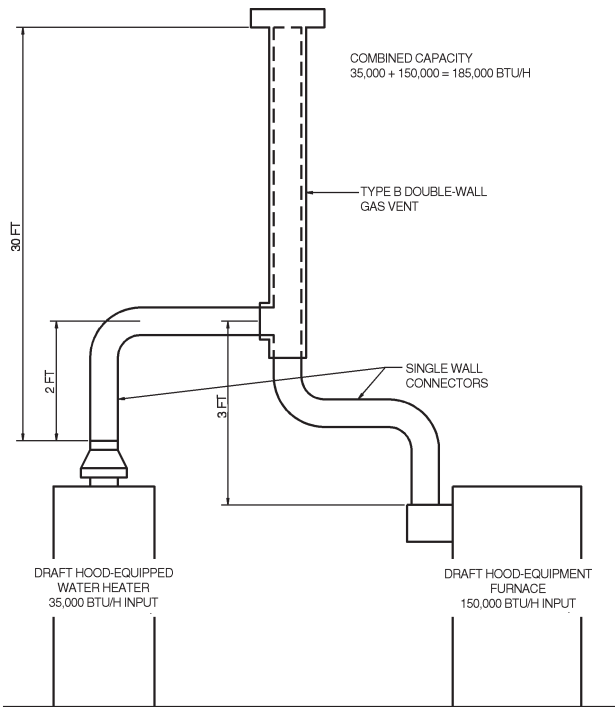

**FIGURE B-17 (EXAMPLE 4)
COMMON VENTING TWO DRAFT-
HOOD-EQUIPPED APPLIANCES**

In the common vent capacity portion of Table G2428.3(2), find the row associated with a 30-foot vent height and read over to the NAT + NAT portion of the 6-inch-diameter column to find a maximum combined capacity of 257,000 Btu per hour. Since the two appliances total only 185,000 Btu per hour, a 6-inch common vent may be used.

Example 5a: Common venting a draft-hood-equipped water heater with a fan-assisted furnace into a Type B vent.

In this case, a 35,000 Btu per hour input draft-hood-equipped *water heater* with a 4-inch-diameter draft hood outlet, 2 feet of connector rise, and 4 feet of horizontal length is to be common vented with a 100,000 Btu per hour fan-assisted *furnace* with a 4-inch-diameter flue collar, 3 feet of connector rise, and 6 feet of horizontal length. The common vent consists of a 30-foot height of Type B vent. What are the recommended vent diameters for each connector and the common vent? The installer would like to use a single-wall metal vent connector.

Solution:

Water Heater Vent Connector Diameter. Since the *water heater vent connector* horizontal length of 4 feet is less than the maximum value listed in Section G2428.3.2, the venting table values may be used without adjustments. Using the *Vent Connector Capacity* portion of Table G2428.3(2), read down the Total Vent Height (H) column to 30 feet and read across the 2-foot Connector Rise (R) row to the first Btu per hour rating in the NAT Max column that is equal to or greater than the *water heater* input rating. The table shows that a 3-inch vent connector has a maximum input rating of 37,000 Btu per hour. Although this is greater than the *water heater* input rating, a 3-inch vent connector is prohibited by Section G2428.3.17. A 4-

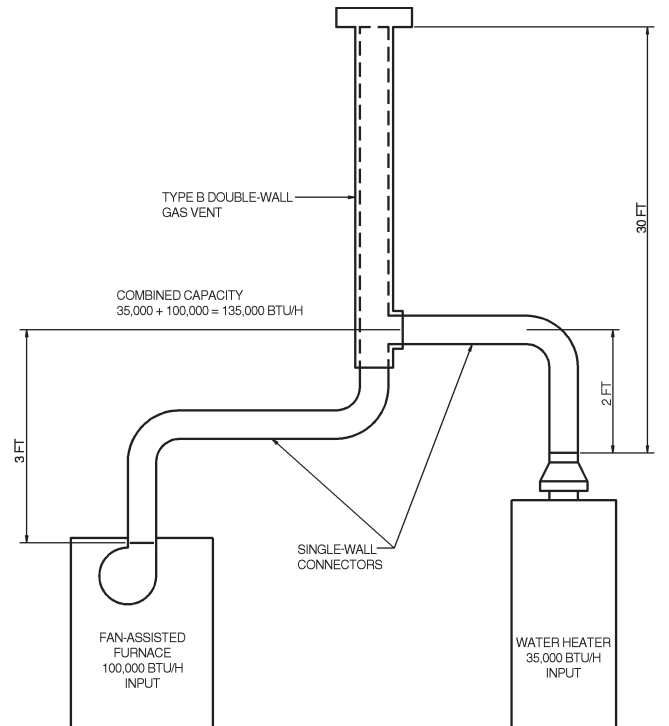

**FIGURE B-18 (EXAMPLE 5A)
COMMON VENTING A DRAFT HOOD WITH A FAN-ASSISTED
FURNACE INTO A TYPE B DOUBLE-WALL COMMON VENT**

inch *vent connector* has a maximum input rating of 67,000 *Btu* per hour and is equal to the *draft hood* outlet diameter. A 4-inch *vent connector* is selected. Since the *water heater* is equipped with a *draft hood*, there are no minimum input rating restrictions.

Furnace Vent Connector Diameter. Using the *Vent Connector Capacity* portion of Table G2428.3(2), read down the Total Vent Height (*H*) column to 30 feet and across the 3-foot Connector Rise (*R*) row. Since the *furnace* has a fan-assisted *combustion* system, find the first FAN Max column with a *Btu* per hour rating greater than the *furnace* input rating. The 4-inch *vent connector* has a maximum input rating of 119,000 *Btu* per hour and a minimum input rating of 85,000 *Btu* per hour. The 100,000 *Btu* per hour *furnace* in this example falls within this range, so a 4-inch connector is adequate. Since the *furnace vent connector* horizontal length of 6 feet does not exceed the maximum value listed in Section G2428.3.2, the venting table values may be used without adjustment. If the *furnace* had an input rating of 80,000 *Btu* per hour, then a Type B *vent connector* [see Table G2428.3(1)] would be needed in order to meet the minimum capacity limit.

Common Vent Diameter. The total input to the common *vent* is 135,000 *Btu* per hour. Using the Common Vent Capacity portion of Table G2428.3(2), read down the Total Vent Height (*H*) column to 30 feet and across this row to find the smallest vent diameter in the FAN + NAT column that has a *Btu* per hour rating equal to or greater than 135,000 *Btu* per hour. The 4-inch common vent has a capacity of 132,000 *Btu* per hour and the 5-inch common vent has a capacity of 202,000 *Btu* per hour. Therefore, the 5-inch common vent should be used in this example.

Summary. In this example, the installer may use a 4-inch-diameter, single-wall metal *vent connector* for the *water heater* and a 4-inch-diameter, single-wall metal *vent connector* for the *furnace*. The common vent should be a 5-inch-diameter Type B vent.

Example 5b: Common venting into a masonry chimney.

In this case, the *water heater* and fan-assisted *furnace* of Example 5a are to be common vented into a clay tile-lined *masonry chimney* with a 30-foot height. The *chimney* is not exposed to the outdoors below the roof line. The internal dimensions of the clay tile liner are nominally 8 inches by 12 inches. Assuming the same *vent connector* heights, laterals, and materials found in Example 5a, what are the recommended *vent connector* diameters, and is this an acceptable installation?

Solution:

Table G2428.3(4) is used to size common venting installations involving single-wall connectors into *masonry chimneys*.

Water Heater Vent Connector Diameter. Using Table G2428.3(4), *Vent Connector Capacity*, read down the Total Vent Height (*H*) column to 30 feet, and read across the 2-foot Connector Rise (*R*) row to the first *Btu* per hour rating in the NAT Max column that is equal to or greater than the *water heater* input rating. The table shows that a 3-inch *vent connector* has a maximum input of only 31,000 *Btu* per hour while a 4-inch *vent connector* has a maximum input of 57,000 *Btu* per hour. A 4-inch *vent connector* must therefore be used.

Furnace Vent Connector Diameter. Using the *Vent Connector Capacity* portion of Table G2428.3(4), read down the Total Vent Height (*H*) column to 30 feet and across the 3-foot Connector Rise (*R*) row. Since the *furnace* has a fan-assisted *combustion* system, find the first FAN Max column with a *Btu* per hour rating greater than the *furnace* input rating. The 4-inch *vent connector* has a maximum input rating of 127,000 *Btu* per hour and a minimum input rating of 95,000 *Btu* per hour. The 100,000 *Btu* per hour *furnace* in this example falls within this range, so a 4-inch connector is adequate.

Masonry Chimney. From Table B-1, the equivalent area for a nominal liner size of 8 inches by 12 inches is 63.6 square inches. Using Table G2428.3(4), Common Vent Capacity, read down the FAN + NAT column under the Minimum Internal Area of *Chimney* value of 63 to the row for 30-foot height to find a capacity value of 739,000 *Btu* per hour. The combined input rating of the *furnace* and *water heater*, 135,000 *Btu* per hour, is less than the table value, so this is an acceptable installation.

Section G2428.3.13 requires the common vent area to be no greater than seven times the smallest listed appliance categorized *vent* area, *flue collar* area, or *draft hood* outlet area. Both appliances in this installation have 4-inch-diameter outlets. From Table B-1, the equivalent area for an inside diameter of 4 inches is 12.2 square inches. Seven times 12.2 equals 85.4, which is greater than 63.6, so this configuration is acceptable.

Example 5c: Common venting into an exterior masonry chimney.

In this case, the *water heater* and fan-assisted *furnace* of Examples 5a and 5b are to be common vented into an exterior *masonry chimney*. The *chimney* height, clay tile liner dimensions, and *vent connector* heights and laterals are the same as in Example 5b. This system is being installed in Charlotte, North Carolina. Does this exterior *masonry chimney* need to be relined? If so, what corrugated metallic liner size is recommended? What *vent connector* diameters are recommended?

Solution:

According to Section 504.3.20 of the *International Fuel Gas Code*, Type B *vent connectors* are required to be used with *exterior masonry chimneys*. Use Table 504.3(7) of the *International Fuel Gas Code* to size FAN+NAT common venting installations involving Type-B double wall connectors into *exterior masonry chimneys*.

The local 99-percent winter design temperature needed to use Table 504.3(7) can be found in the ASHRAE *Handbook of Fundamentals*. For Charlotte, North Carolina, this design temperature is 19°F.

Chimney Liner Requirement. As in Example 5b, use the 63 square inch Internal Area columns for this size clay tile liner. Read down the 63 square inch column of Table 504.3(7a) of the *International Fuel Gas Code* to the 30-foot height row to find that the combined appliance maximum input is 747,000 *Btu* per hour. The combined input rating of the appliances in this installation, 135,000 *Btu* per hour, is less than the maximum value, so this criterion is satisfied. Table 504.3(7b), at a 19°F design temperature, and at the same vent height and internal area used above, shows that the minimum allowable input rating of a

space-heating appliance is 470,000 *Btu* per hour. The *furnace* input rating of 100,000 *Btu* per hour is less than this minimum value. So this criterion is not satisfied, and an alternative venting design needs to be used, such as a Type B vent shown in Example 5a or a listed *chimney* liner system shown in the remainder of the example.

According to Section G2428.3.15, Table G2428.3(1) or G2428.3(2) is used for sizing corrugated metallic liners in *masonry chimneys*, with the maximum common vent capacities reduced by 20 percent. This example will be continued assuming Type B *vent connectors*.

Water Heater Vent Connector Diameter. Using Table G2428.3(1), *Vent Connector Capacity*, read down the Total Vent Height (*H*) column to 30 feet, and read across the 2-foot Connector Rise (*R*) row to the first *Btu/h* rating in the NAT Max column that is equal to or greater than the *water heater* input rating. The table shows that a 3-inch *vent connector* has a maximum capacity of 39,000 *Btu/h*. Although this rating is greater than the *water heater* input rating, a 3-inch *vent connector* is prohibited by Section G2428.3.17. A 4-inch *vent connector* has a maximum input rating of 70,000 *Btu/h* and is equal to the *draft hood* outlet diameter. A 4-inch *vent connector* is selected.

Furnace Vent Connector Diameter. Using Table G2428.3(1), *Vent Connector Capacity*, read down the Vent Height (*H*) column to 30 feet, and read across the 3-foot Connector Rise (*R*) row to the first *Btu* per hour rating in the FAN Max column that is equal to or greater than the *furnace* input rating. The 100,000 *Btu* per hour *furnace* in this example falls within this range, so a 4-inch connector is adequate.

Chimney Liner Diameter. The total input to the common vent is 135,000 *Btu* per hour. Using the Common Vent Capacity Portion of Table G2428.3(1), read down the Vent Height (*H*) column to 30 feet and across this row to find the smallest *vent* diameter in the FAN+NAT column that has a *Btu* per hour rating greater than 135,000 *Btu* per hour. The 4-inch common *vent* has a capacity of 138,000 *Btu* per hour. Reducing the maximum capacity by 20 percent (Section G2428.3.15) results in a maximum capacity for a 4-inch corrugated liner of 110,000 *Btu* per hour, less than the total input of 135,000 *Btu* per hour. So a larger liner is needed. The 5-inch common vent capacity listed in Table G2428.3(1) is 210,000 *Btu* per hour, and after reducing by 20 percent is 168,000 *Btu* per hour. Therefore, a 5-inch corrugated metal liner should be used in this example.

Single-Wall Connectors. Once it has been established that relining the *chimney* is necessary, Type B double-wall *vent connectors* are not specifically required. This example could be redone using Table G2428.3(2) for single-wall *vent connectors*. For this case, the *vent connector* and liner diameters would be the same as found above with Type B double-wall connectors.

TABLE B-1
MASONRY CHIMNEY LINER DIMENSIONS
WITH CIRCULAR EQUIVALENTS^a

NOMINAL LINER SIZE (inches)	INSIDE DIMENSIONS OF LINER (inches)	INSIDE DIAMETER OR EQUIVALENT DIAMETER (inches)	EQUIVALENT AREA (square inches)
4 × 8	2½ × 6½	4	12.2
		5	19.6
		6	28.3
		7	38.3
8 × 8	6¾ × 6¾	7.4	42.7
		8	50.3
8 × 12	6½ × 10½	9	63.6
		10	78.5
12 × 12	9¾ × 9¾	10.4	83.3
		11	95
12 × 16	9½ × 13½	11.8	107.5
		12	113.0
		14	153.9
16 × 16	13¼ × 13¼	14.5	162.9
		15	176.7
16 × 20	13 × 17	16.2	206.1
		18	254.4
20 × 20	16¾ × 16¾	18.2	260.2
		20	314.1
20 × 24	16½ × 20½	20.1	314.2
		22	380.1
24 × 24	20¼ × 20¼	22.1	380.1
		24	452.3
24 × 28	20¼ × 20¼	24.1	456.2
		26.4	543.3
28 × 28	24¼ × 24¼	27	572.5
		27.9	607
30 × 30	25½ × 25½	30	706.8
		30.9	749.9
30 × 36	25½ × 31½	33	855.3
		34.4	929.4
36 × 36	31½ × 31½	36	1017.9

For SI: 1 inch = 25.4 mm, 1 square inch = 645.16 mm².

a. Where liner sizes differ dimensionally from those shown in Table B-1, equivalent diameters may be determined from published tables for square and rectangular ducts of equivalent carrying capacity or by other engineering methods.

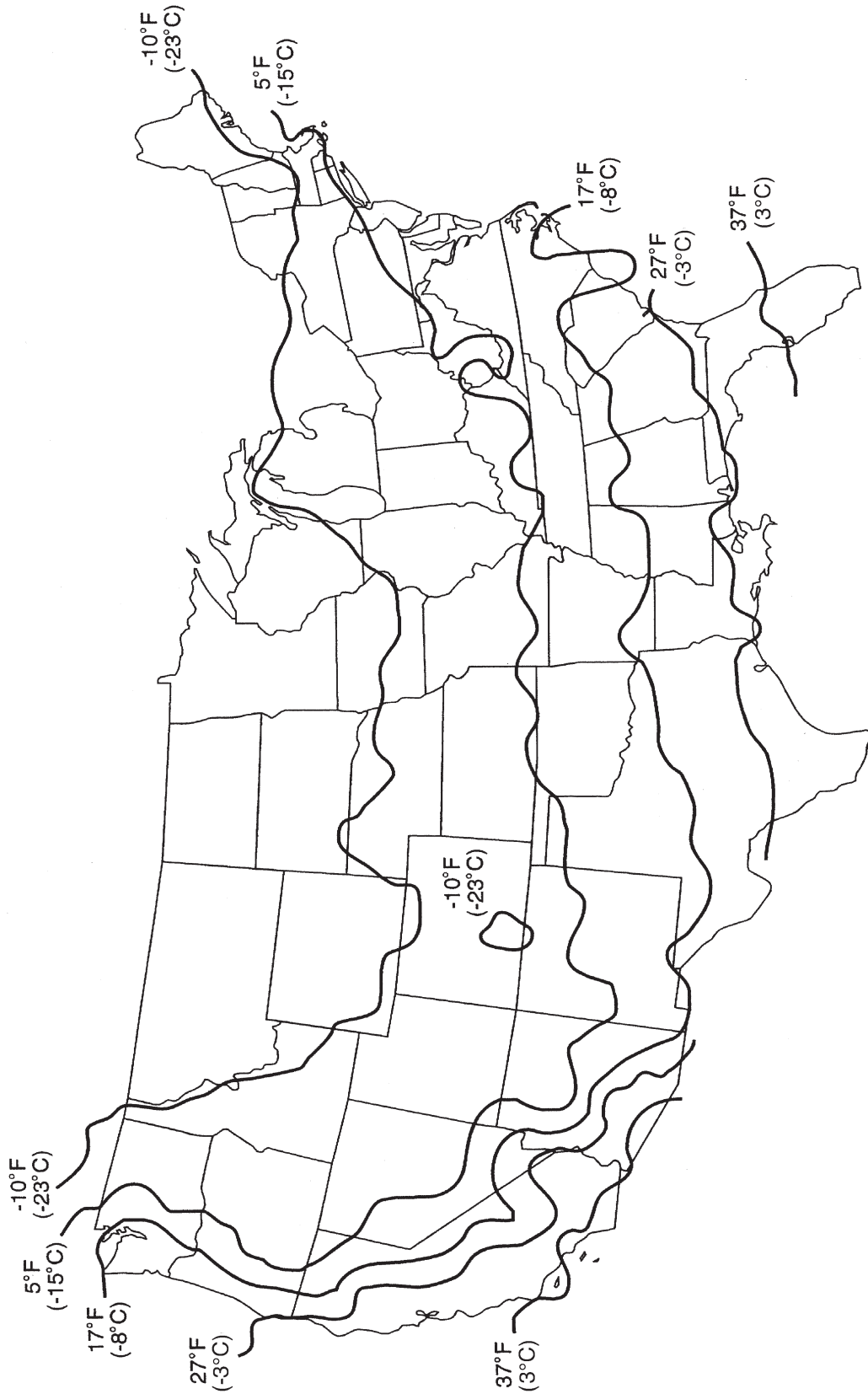

FIGURE B-19

APPENDIX C

EXIT TERMINALS OF MECHANICAL DRAFT AND DIRECT-VENT VENTING SYSTEMS

(Not Adopted by the State of Oregon)

(This appendix is informative and is not part of the code. This appendix is an excerpt from the 2009 *International Fuel Gas Code*, coordinated with the section numbering of the *International Residential Code*.)

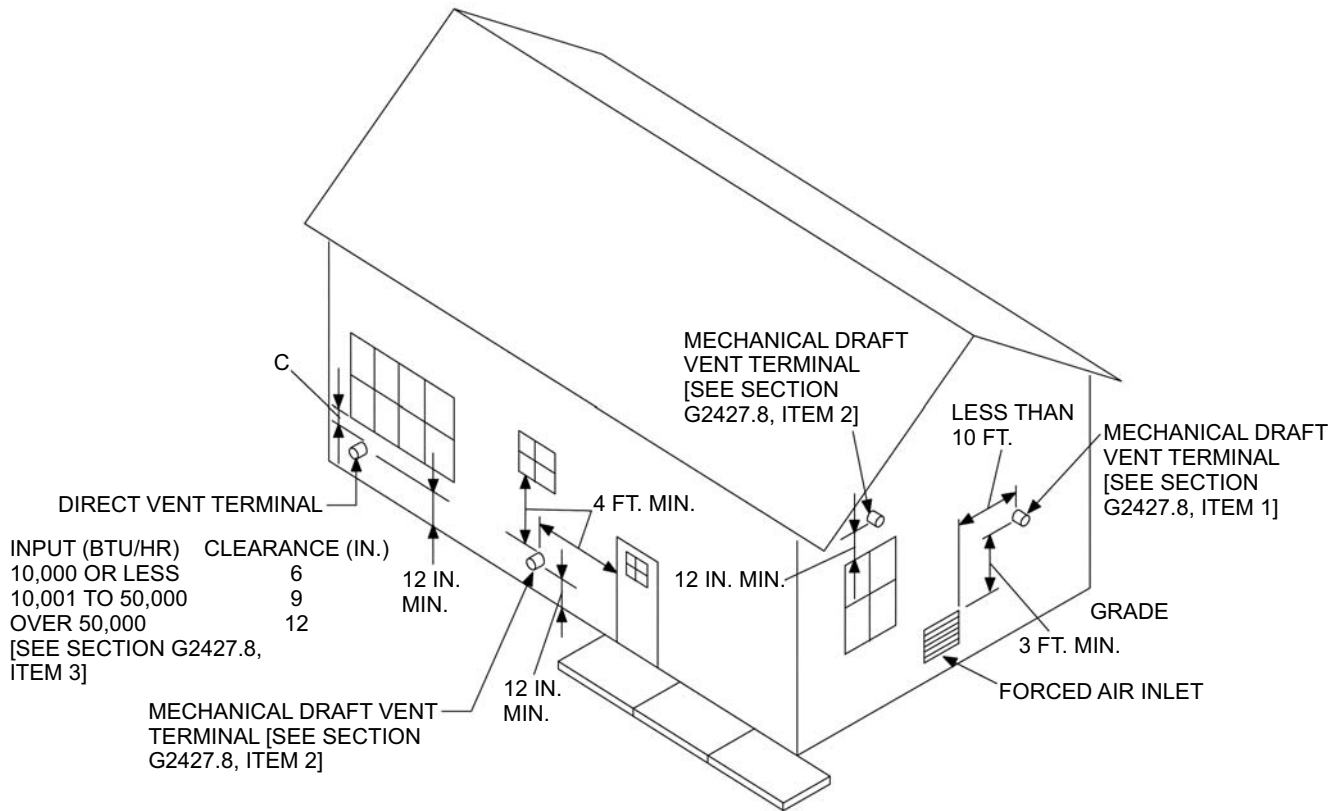

For SI: 1 inch = 25.4 mm, 1 foot = 304.8 mm, 1 British thermal unit per hour = 0.2931 W.

FIGURE C-1
EXIT TERMINALS OF MECHANICAL DRAFT AND DIRECT-VENT VENTING SYSTEMS

APPENDIX D

RECOMMENDED PROCEDURE FOR SAFETY INSPECTION OF AN EXISTING APPLIANCE INSTALLATION

(Not Adopted by the State of Oregon)

(This appendix is informative and is not part of the *code*. This appendix is an excerpt from the 2009 *International Fuel Gas Code*, coordinated with the section numbering of the *International Residential Code*.)

The following procedure is intended as a guide to aid in determining that an *appliance* is properly installed and is in a safe condition for continuing use.

This procedure is intended for *central furnace* and boiler installations and may not be applicable to all installations.

- (a) This procedure should be performed prior to any attempt at modification of the *appliance* or of the installation.
- (b) If it is determined that there is a condition that could result in unsafe operation, shut off the *appliance* and advise the owner of the unsafe condition.

The following steps should be followed in making the safety inspection:

1. Conduct a check for gas leakage. (See Section G2417.6.)
2. Visually inspect the *venting system* for proper size and horizontal pitch and determine there is no blockage or restriction, leakage, corrosion and other deficiencies that could cause an unsafe condition.
3. Shut off all gas to the *appliance* and shut off any other fuel-gas-burning *appliance* within the same room. Use the shut-off valve in the supply line to each *appliance*.
4. Inspect *burners* and crossovers for blockage and corrosion.
5. **Furnace installations:** Inspect the heat exchanger for cracks, openings or excessive corrosion.
6. **Boiler installations:** Inspect for evidence of water or *combustion product* leaks.
7. Close all building doors and windows and all doors between the space in which the *appliance* is located and other spaces of the building that can be closed. Turn on any *clothes dryers*. Turn on any exhaust fans, such as range hoods and bathroom exhausts, so they will operate at maximum speed. Do not operate a summer exhaust fan. Close *fireplace dampers*. If, after completing Steps 8 through 13, it is believed sufficient *combustion air* is not available, refer to Section G2407 of this *code*.
8. Place the *appliance* being inspected in operation. Follow the lighting instructions. Adjust the *thermostat* so that the *appliance* will operate continuously.
9. Determine that the *pilot*, where provided, is burning properly and that the *main burner* ignition is satisfactory by interrupting and reestablishing the electrical

supply to the *appliance* in any convenient manner. If the *appliance* is equipped with a continuous *pilot*, test all *pilot* safety devices to determine if they are operating properly by extinguishing the *pilot* when the *main burner* is off and determining, after 3 minutes, that the *main burner* gas does not flow upon a call for heat. If the *appliance* is not provided with a *pilot*, test for proper operation of the ignition system in accordance with the *appliance* manufacturer's lighting and operating instructions.

10. Visually determine that the *main burner* gas is burning properly (i.e., no floating, lifting or flashback). Adjust the primary air shutters as required.

If the *appliance* is equipped with high and low flame controlling or flame modulation, check for proper *main burner* operation at low flame.

11. Test for spillage at the *draft hood relief opening* after 5 minutes of *main burner* operation. Use the flame of a match or candle or smoke.
12. Turn on all other fuel-gas-burning *appliances* within the same room so they will operate at their full inputs. Follow lighting instructions for each *appliance*.
13. Repeat Steps 10 and 11 on the *appliance* being inspected.
14. Return doors, windows, exhaust fans, *fireplace dampers* and any other fuel-gas-burning *appliance* to their previous conditions of use.
15. **Furnace installations:** Check both the limit *control* and the fan *control* for proper operation. Limit *control* operation can be checked by blocking the circulating air inlet or temporarily disconnecting the electrical supply to the blower motor and determining that the limit *control* acts to shut off the *main burner* gas.
16. **Boiler installations:** Verify that the water pumps are in operating condition. Test low water cutoffs, automatic feed *controls*, pressure and temperature limit *controls*, and *relief valves* in accordance with the manufacturer's recommendations to determine that they are in operating condition.

APPENDIX E

MANUFACTURED HOUSING USED AS DWELLINGS

>

SECTION AE101 ANCHORAGE INSTALLATIONS

AE101.1 Ground anchors. Ground anchors shall be designed and installed to transfer the anchoring loads to the ground. The load-carrying portion of the ground anchors shall be installed to the full depth called for by the manufacturer's installation directions and shall extend below the established frost line into undisturbed soil.

Manufactured ground anchors shall be listed and installed in accordance with the terms of their listing and the anchor manufacturer's instructions and shall include means of attachment of ties meeting the requirements of Section AE102. Ground anchor manufacturer's installation instructions shall include the amount of preload required and load capacity in various types of soil. These instructions shall include tensioning adjustments which may be needed to prevent damage to the manufactured home, particularly damage that can be caused by frost heave. Each ground anchor shall be marked with the manufacturer's identification and listed model identification number which shall be visible after installation. Instructions shall accompany each listed ground anchor specifying the types of soil for which the anchor is suitable under the requirements of this section.

Each approved ground anchor, when installed, shall be capable of resisting an allowable working load at least equal to 3,150 pounds (14 kN) in the direction of the tie plus a 50 percent overload [4,725 pounds (21 kN) total] without failure. Failure shall be considered to have occurred when the anchor moves more than 2 inches (51 mm) at a load of 4,725 pounds (21 kN) in the direction of the tie installation. Those ground anchors which are designed to be installed so that loads on the anchor are other than direct withdrawal shall be designed and installed to resist an applied design load of 3,150 pounds (14 kN) at 40 to 50 degrees from vertical or within the angle limitations specified by the home manufacturer without displacing the tie end of the anchor more than 4 inches (102 mm) horizontally. Anchors designed for connection of multiple ties shall be capable of resisting the combined working load and overload consistent with the intent expressed herein.

When it is proposed to use ground anchors and the building official has reason to believe that the soil characteristics at a given site are such as to render the use of ground anchors advisable, or when there is doubt regarding the ability of the ground anchors to obtain their listed capacity, the building official may require that a representative field installation be made at the site in question and tested to demonstrate ground anchor capacity. The building official shall approve the test procedures.

AE101.2 Anchoring equipment. Anchoring equipment, when installed as a permanent installation, shall be capable of resisting all loads as specified within these provisions. When

the stabilizing system is designed by an engineer or architect licensed by the state to practice as such, alternative designs may be used, providing the anchoring equipment to be used is capable of withstanding a load equal to 1.5 times the calculated load. All anchoring equipment shall be listed and labeled as being capable of meeting the requirements of these provisions. Anchors as specified in this code may be attached to the main frame of the manufactured home by an approved $\frac{3}{16}$ -inch-thick (4.76 mm) slotted steel plate anchoring device. Other anchoring devices or methods meeting the requirements of these provisions may be permitted when approved by the building official.

Anchoring systems shall be so installed as to be permanent. Anchoring equipment shall be so designed to prevent self disconnection with no hook ends used.

AE101.3 Resistance to weather deterioration. All anchoring equipment, tension devices and ties shall have a resistance to deterioration as required by this code.

AE101.4 Tensioning devices. Tensioning devices, such as turnbuckles or yoke-type fasteners, shall be ended with clevis or welded eyes.

SECTION AE102 TIES, MATERIALS AND INSTALLATION

AE102.1 General. Steel strapping, cable, chain or other approved materials shall be used for ties. All ties shall be fastened to ground anchors and drawn tight with turnbuckles or other adjustable tensioning devices or devices supplied with the ground anchor. Tie materials shall be capable of resisting an allowable working load of 3,150 pounds (14 kN) with no more than 2 percent elongation and shall withstand a 50 percent overload [4,750 pounds (21 kN)]. Ties shall comply with the weathering requirements of Section AE101.3. Ties shall connect the ground anchor and the main structural frame. Ties shall not connect to steel outrigger beams which fasten to and intersect the main structural frame unless specifically stated in the manufacturer's installation instructions. Connection of cable ties to main frame members shall be $\frac{5}{8}$ -inch (15.9 mm) closed-eye bolts affixed to the frame member in an approved manner. Cable ends shall be secured with at least two U-bolt cable clamps with the U portion of the clamp installed on the short (dead) end of the cable to assure strength equal to that required by this section.

Wood floor support systems shall be fixed to perimeter foundation walls in accordance with provisions of this code. The minimum number of ties required per side shall be sufficient to resist the wind load stated in this code. Ties shall be evenly spaced as practicable along the length of the manufactured home with the distance from each end of the home and the tie

APPENDIX E

nearest that end not exceeding 8 feet (2438 mm). When continuous straps are provided as vertical ties, such ties shall be positioned at rafters and studs. Where a vertical tie and diagonal tie are located at the same place, both ties may be connected to a single anchor, provided the anchor used is capable of carrying both loadings. Multi-section manufactured homes require diagonal ties only. Diagonal ties shall be installed on the exterior main frame and slope to the exterior at an angle of 40 to 50 degrees from the vertical or within the angle limitations specified by the home manufacturer. Vertical ties which are not continuous over the top of the manufactured home shall be attached to the main frame.

>

APPENDIX F

RADON CONTROL METHODS

The provisions contained in this appendix are not mandatory, except for areas specified in Section AF101.1

SECTION AF101 SCOPE

AF101.1 General. This appendix contains requirements for new construction in Baker, Clackamas, Hood River, Multnomah, Polk, Washington and Yamhill counties where radon-mitigating construction is required. Additional counties may be added as specified in Chapter 83, 2010 Oregon Laws (Senate Bill 1025), Section 2.

Chapter 83, 2010 Oregon Laws (Senate Bill 1025) is not part of this code but is reproduced here for the reader's convenience:
SECTION 2.

(1) The Building Codes Structures Board and the Residential and Manufactured Structures Board shall adopt design and construction standards for mitigating radon levels in new residential buildings that are identified under the structural specialty code as Group R-2 or R-3 buildings and new public buildings. In adopting the standards, the boards shall give consideration to any standards recommended by the United States Environmental Protection Agency for radon mitigation systems in buildings.

(2) The boards shall make the design and construction standards for mitigating radon levels applicable in:

- (a) Baker, Clackamas, Hood River, Multnomah, Polk, Washington and Yamhill Counties; and
- (b) Any county for which the boards, after consultation with the Oregon Health Authority, consider the standards appropriate due to local radon levels.

(3) The Director of the Department of Consumer and Business Services may authorize a municipality that administers and enforces one or more building inspection programs under ORS 455.148 or 455.150 to also administer and enforce any applicable standards for mitigating radon that are adopted by the boards.

(4) The director, in consultation with the boards, may adopt rules for the implementation, administration and enforcement of this section.

SECTION AF102 DEFINITIONS

AF102.1 General. For the purpose of these requirements, the terms used shall be defined as follows:

SUBSLAB DEPRESSURIZATION SYSTEM (Passive). A system designed to achieve lower sub-slab air pressure relative to indoor air pressure by use of a vent pipe routed through the *conditioned space* of a building and connecting the sub-slab area with outdoor air, thereby relying on the convective flow of air upward in the vent to draw air from beneath the slab.

SUBSLAB DEPRESSURIZATION SYSTEM (Active). A system designed to achieve lower sub-slab air pressure relative to indoor air pressure by use of a fan-powered vent drawing air from beneath the slab.

DRAIN TILE LOOP. A continuous length of drain tile or perforated pipe extending around all or part of the internal or external perimeter of a *basement* or crawl space footing.

RADON GAS. A naturally-occurring, chemically inert, radioactive gas that is not detectable by human senses. As a gas, it can move readily through particles of soil and rock and can accumulate under the slabs and foundations of homes where it can easily enter into the living space through construction cracks and openings.

SOIL-GAS-RETARDER. A continuous membrane of 6-mil (0.15 mm) polyethylene or other equivalent material used to retard the flow of soil gases into a building.

SUBMEMBRANE DEPRESSURIZATION SYSTEM. A system designed to achieve lower-sub-membrane air pressure relative to crawl space air pressure by use of a vent drawing air from beneath the soil-gas-retarder membrane.

SECTION AF103 REQUIREMENTS

AF103.1 General. The following construction techniques are intended to mitigate radon entry in new construction. These techniques are required in areas where designated by Section AF101.1.

AF103.2 Subfloor preparation. A layer of gas-permeable material shall be placed under all concrete slabs and other floor systems that directly contact the ground and are within the walls of the living spaces of the building, to facilitate future installation of a sub-slab depressurization system, if needed. The gas-permeable layer shall consist of one of the following:

1. A uniform layer of clean aggregate, a minimum of 4 inches (102 mm) thick. The aggregate shall consist of material that will pass through a 2-inch (51 mm) sieve and be retained by a 1/4-inch (6.4 mm) sieve.
2. A uniform layer of sand (native or fill), a minimum of 4 inches (102 mm) thick, overlain by a layer or strips of geotextile drainage matting designed to allow the lateral flow of soil gases.
3. Other materials, systems or floor designs with demonstrated capability to permit depressurization across the entire sub-floor area.

AF103.3 Soil-gas-retarder. A minimum 6-mil (0.15 mm) [or 3-mil (0.075 mm) cross-laminated] polyethylene or equivalent flexible sheeting material shall be placed on top of the gas-permeable layer prior to casting the slab or placing the floor assembly to serve as a soil-gas-retarder by bridging any cracks that develop in the slab or floor assembly and to prevent concrete from entering the void spaces in the aggregate base material. The sheeting shall cover the entire floor area with separate

sections of sheeting lapped at least 12 inches (305 mm). The sheeting shall fit closely around any pipe, wire or other penetrations of the material. All punctures or tears in the material shall be sealed or covered with additional sheeting.

AF103.4 Entry routes. Potential radon entry routes shall be closed in accordance with Sections AF103.4.1 through AF103.4.10.

AF103.4.1 Floor openings. Openings around bathtubs, showers, water closets, pipes, wires or other objects that penetrate concrete slabs or other floor assemblies shall be filled with a polyurethane caulk or equivalent sealant applied in accordance with the manufacturer's recommendations.

AF103.4.2 Concrete joints. All control joints, isolation joints, construction joints and any other joints in concrete slabs or between slabs and foundation walls shall be sealed with a caulk or sealant. Gaps and joints shall be cleared of loose material and filled with polyurethane caulk or other elastomeric sealant applied in accordance with the manufacturer's recommendations.

AF103.4.3 Condensate drains. Condensate drains shall be trapped or routed through nonperforated pipe to daylight.

AF103.4.4 Sumps. Sump pits open to soil or serving as the termination point for sub-slab or exterior drain tile loops shall be covered with a gasketed or otherwise sealed lid. Sumps used as the suction point in a sub-slab depressurization system shall have a lid designed to accommodate the vent pipe. Sumps used as a floor drain shall have a lid equipped with a trapped inlet.

AF103.4.5 Foundation walls. Hollow block masonry foundation walls shall be constructed with either a continuous course of *solid masonry*, one course of masonry grouted solid, or a solid concrete beam at or above finished ground surface to prevent passage of air from the interior of the wall into the living space. Where a brick veneer or other masonry ledge is installed, the course immediately below that ledge shall be sealed. Joints, cracks or other openings around all penetrations of both exterior and interior surfaces of masonry block or wood foundation walls below the ground surface shall be filled with polyurethane caulk or equivalent sealant. Penetrations of concrete walls shall be filled.

AF103.4.6 Dampproofing. The exterior surfaces of portions of concrete and masonry block walls below the ground surface shall be dampproofed in accordance with Section R406 of this code.

AF103.4.7 Air-handling units. Air-handling units in crawl spaces shall be sealed to prevent air from being drawn into the unit.

Exception: Units with gasketed seams or units that are otherwise sealed by the manufacturer to prevent leakage.

AF103.4.8 Ducts. Ductwork passing through or beneath a slab shall be of seamless material unless the air-handling system is designed to maintain continuous positive pressure within such ducting. Joints in such ductwork shall be sealed to prevent air leakage and shall be performance tested to

demonstrate conformance to ODOE duct performance standards.

Ductwork located in crawl spaces shall have all seams and joints sealed by closure systems in accordance with Section M1601.4.1. Ductwork shall be performance tested to demonstrate conformance to ODOE duct performance standards.

AF103.4.9 Crawl space floors. Openings around all penetrations through floors above crawl spaces shall be caulked or otherwise filled to prevent air leakage.

AF103.4.10 Crawl space access. Access doors and other openings or penetrations between *basements* and adjoining crawl spaces shall be closed, gasketed or otherwise filled to prevent air leakage.

AF103.5 Crawl space mitigation system. In buildings with crawl space foundations, a system complying with Section AF103.5.1 or AF103.5.2 shall be installed during construction.

Exception: Buildings in which an approved mechanical crawl space ventilation system or other equivalent system is installed.

AF103.5.1 Passive submembrane depressurization system.

AF103.5.1.1 Ventilation. Crawl spaces shall be provided with vents to the exterior of the building. The minimum net area of ventilation openings shall comply with Section R408.1 of this code.

AF103.5.1.2 Soil-gas-retarder. The soil in crawl spaces shall be covered with a continuous layer of minimum 6-mil (0.15 mm) polyethylene soil-gas-retarder. The ground cover shall be lapped a minimum of 12 inches (305 mm) at joints and shall extend to all foundation walls enclosing the crawl space area.

AF103.5.1.3 Vent pipe. A plumbing tee or other *approved* connection shall be inserted horizontally beneath the sheeting and connected to a 3- or 4-inch-diameter (76 mm or 102 mm) fitting with a vertical vent pipe installed through the sheeting. The vent pipe shall be extended up through the building floors, terminate at least 12 inches (305 mm) above the roof in a location at least 10 feet (3048 mm) away from any window or other opening into the *conditioned spaces* of the building that is less than 2 feet (610 mm) below the exhaust point, and 10 feet (3048 mm) from any window or other opening in adjoining or adjacent buildings.

AF103.5.2 Crawl space ventilation and building tightness.

AF103.5.2.1 Ventilation. Crawl spaces shall be provided with vents to the exterior of the building that comply with Section R408.1 of this code. The minimum net area of ventilation openings shall not be less than 1 square foot (0.0929 m²) for each 150 square feet (14 m²) of under-floor space area.

AF103.5.2.2 Ventilation openings. Ventilation openings shall comply with Section R408.2. Operable louvers, dampers, or other means to temporarily stop the ventilation shall not be permitted.

AF103.5.2.3 Building tightness. Dwellings shall be tested with a blower door, depressurizing the dwelling to 50 Pascal's from ambient conditions and found to exhibit no more than 5.0 air changes per hour. A mechanical exhaust, supply, or combination ventilation system providing whole-building ventilation rates specified in Table N1101.1(3) or ASHRAE 62.2 shall be installed within the dwelling unit.

AF103.6 Passive subslab depressurization system. In *basement* or slab-on-grade buildings, the following components of a passive sub-slab depressurization system shall be installed during construction.

AF103.6.1 Vent pipe. A minimum 3-inch-diameter (76 mm) ABS, PVC or equivalent gas-tight pipe shall be embedded vertically into the sub-slab aggregate or other permeable material before the slab is cast. A "T" fitting or equivalent method shall be used to ensure that the pipe opening remains within the sub-slab permeable material. Alternatively, the 3-inch (76 mm) pipe shall be inserted directly into an interior perimeter drain tile loop or through a sealed sump cover where the sump is exposed to the sub-slab aggregate or connected to it through a drainage system.

The pipe shall be extended up through the building floors, terminate at least 12 inches (305 mm) above the surface of the roof in a location at least 10 feet (3048 mm) away from any window or other opening into the *conditioned spaces* of the building that is less than 2 feet (610 mm) below the exhaust point, and 10 feet (3048 mm) from any window or other opening in adjoining or adjacent buildings.

AF103.6.2 Multiple vent pipes. In buildings where interior footings or other barriers separate the sub-slab aggregate or other gas-permeable material, each area shall be fitted with an individual vent pipe. Vent pipes shall connect to a single vent that terminates above the roof or each individual vent pipe shall terminate separately above the roof.

AF103.7 Vent pipe drainage. All components of the radon vent pipe system shall be installed to provide positive drainage to the ground beneath the slab or soil-gas-retarder.

AF103.8 Vent pipe accessibility. Radon vent pipes shall be accessible for future fan installation through an *attic* or other area outside the *habitable space*.

Exception: The radon vent pipe need not be accessible in an *attic* space where an *approved* roof-top electrical supply is provided for future use.

AF103.9 Vent pipe identification. All exposed and visible interior radon vent pipes shall be identified with at least one *label* on each floor and in accessible *attics*. The *label* shall read: "Radon Reduction System."

AF103.10 Combination foundations. Combination *basement/crawl space* or slab-on-grade/crawl space foundations shall have separate radon vent pipes installed in each type of foundation area. Each radon vent pipe shall terminate above the roof or shall be connected to a single vent that terminates above the roof.

AF103.11 Building depressurization. Joints in air ducts and plenums in *unconditioned spaces* shall meet the requirements

of Section M1601. Thermal envelope air infiltration requirements shall comply with the energy conservation provisions in Chapter 11. Fireblocking shall meet the requirements contained in Section R302.11.

AF103.12 Power source. To provide for future installation of an active sub-membrane or sub-slab depressurization system, an electrical circuit terminated in an *approved* box shall be installed during construction in the *attic* or other anticipated location of vent pipe fans. An electrical supply shall also be accessible in anticipated locations of system failure alarms.

<

APPENDIX G

SWIMMING POOLS, SPAS AND HOT TUBS

SECTION AG101 GENERAL

AG101.1 General. The provisions of this appendix shall control the design and construction of swimming pools, spas and hot tubs installed in or on the *lot* of a one- or two-family dwelling.

SECTION AG102 DEFINITIONS

AG102.1 General. For the purposes of these requirements, the terms used shall be defined as follows and as set forth in Chapter 2.

ABOVE-GROUND/ON-GROUND POOL. See “Swimming pool.”

BARRIER. A fence, wall, building wall or combination thereof which completely surrounds the swimming pool and obstructs access to the swimming pool.

HOT TUB. See “Swimming pool.”

IN-GROUND POOL. See “Swimming pool.”

RESIDENTIAL. That which is situated on the premises of a detached one- or two-family dwelling or a one-family *townhouse* not more than three stories in height.

SPA, NONPORTABLE. See “Swimming pool.”

SPA, PORTABLE. A nonpermanent structure intended for recreational bathing, in which all controls, water-heating and water-circulating *equipment* are an integral part of the product.

SWIMMING POOL. Any structure intended for swimming or recreational bathing that contains water over 24 inches (610 mm) deep. This includes in-ground, above-ground and on-ground swimming pools, hot tubs and spas.

SWIMMING POOL, INDOOR. A swimming pool which is totally contained within a structure and surrounded on all four sides by the walls of the enclosing structure.

SWIMMING POOL, OUTDOOR. Any swimming pool which is not an indoor pool.

SECTION AG103 SWIMMING POOLS

AG103.1 In-ground pools. In-ground pools shall be designed and constructed in conformance with ANSI/NSPI-5 as listed in Section AG108.

AG103.2 Above-ground and on-ground pools. Not adopted by the State of Oregon.

SECTION AG104 SPAS AND HOT TUBS

AG104.1 Permanently installed spas and hot tubs. Permanently installed spas and hot tubs shall be designed and constructed in conformance with ANSI/NSPI-3 as listed in Section AG108.

AG104.2 Portable spas and hot tubs. Portable spas and hot tubs shall be designed and constructed in conformance with ANSI/NSPI-6 as listed in Section AG108.

SECTION AG105 BARRIER REQUIREMENTS

AG105.1 Application. The provisions of this chapter shall control the design of barriers for residential swimming pools, spas and hot tubs. These design controls are intended to provide protection against potential drownings and near-drownings by restricting access to swimming pools, spas and hot tubs.

AG105.2 Outdoor swimming pool. An outdoor swimming pool, including an in-ground, above-ground or on-ground pool, hot tub or spa shall be surrounded by a barrier which shall comply with the following:

1. The top of the barrier shall be at least 48 inches (1219 mm) above *grade* measured on the side of the barrier which faces away from the swimming pool. The maximum vertical clearance between grade and the bottom of the barrier shall be 2 inches (51 mm) measured on the side of the barrier which faces away from the swimming pool. Where the top of the pool structure is above grade, such as an above-ground pool, the barrier may be at ground level, such as the pool structure, or mounted on top of the pool structure. Where the barrier is mounted on top of the pool structure, the maximum vertical clearance between the top of the pool structure and the bottom of the barrier shall be 4 inches (102 mm).
2. Openings in the barrier shall not allow passage of a 4-inch-diameter (102 mm) sphere.
3. Solid barriers which do not have openings, such as a masonry or stone wall, shall not contain indentations or protrusions except for normal construction tolerances and tooled masonry joints.
4. Where the barrier is composed of horizontal and vertical members and the distance between the tops of the horizontal members is less than 45 inches (1143 mm), the horizontal members shall be located on the swimming pool side of the fence. Spacing between vertical members shall not exceed $1\frac{3}{4}$ inches (44 mm) in width. Where there are decorative cutouts within vertical members, spacing within the cutouts shall not exceed $1\frac{3}{4}$ inches (44 mm) in width.

5. Where the barrier is composed of horizontal and vertical members and the distance between the tops of the horizontal members is 45 inches (1143 mm) or more, spacing between vertical members shall not exceed 4 inches (102 mm). Where there are decorative cutouts within vertical members, spacing within the cutouts shall not exceed 1³/₄ inches (44 mm) in width.
6. Maximum mesh size for chain link fences shall be a 2¹/₄-inch (57 mm) square unless the fence has slats fastened at the top or the bottom which reduce the openings to not more than 1³/₄ inches (44 mm).
7. Where the barrier is composed of diagonal members, such as a lattice fence, the maximum opening formed by the diagonal members shall not be more than 1³/₄ inches (44 mm).
8. Access gates shall comply with the requirements of Section AG105.2, Items 1 through 7, and shall be equipped to accommodate a locking device. Pedestrian access gates shall open outward away from the pool and shall be self-closing and have a self-latching device. Gates other than pedestrian access gates shall have a self-latching device. Where the release mechanism of the self-latching device is located less than 54 inches (1372 mm) from the bottom of the gate, the release mechanism and openings shall comply with the following:
 - 8.1. The release mechanism shall be located on the pool side of the gate at least 3 inches (76 mm) below the top of the gate; and
 - 8.2. The gate and barrier shall have no opening larger than 1/2 inch (12.7 mm) within 18 inches (457 mm) of the release mechanism.
9. Where a wall of a *dwelling* serves as part of the barrier, one of the following conditions shall be met:
 - 9.1. The pool shall be equipped with a powered safety cover in compliance with ASTM F 1346; or
 - 9.2. Other means of protection, such as self-closing doors with self-latching devices, which are *approved* by the governing body, shall be acceptable as long as the degree of protection afforded is not less than the protection afforded by Item 9.1 described above.
10. Where an above-ground pool structure is used as a barrier or where the barrier is mounted on top of the pool structure, and the means of access is a ladder or steps:
 - 10.1. The ladder or steps shall be capable of being secured, locked or removed to prevent access; or
 - 10.2. The ladder or steps shall be surrounded by a barrier which meets the requirements of Section AG105.2, Items 1 through 9. When the ladder or steps are secured, locked or removed, any opening created shall not allow the passage of a 4-inch-diameter (102 mm) sphere.

AG105.3 Indoor swimming pool. Walls surrounding an indoor swimming pool shall comply with Section AG105.2, Item 9.

AG105.4 Prohibited locations. Barriers shall be located to prohibit permanent structures, *equipment* or similar objects from being used to climb them.

AG105.5 Barrier exceptions. Spas or hot tubs with a safety cover which complies with ASTM F 1346, as listed in Section AG107, shall be exempt from the provisions of this appendix.

**SECTION AG106
ENTRAPMENT PROTECTION FOR SWIMMING
POOL AND SPA SUCTION OUTLETS**

AG106.1 General. Suction outlets shall be designed and installed in accordance with ANSI/APSP-7.

**SECTION AG107
ABBREVIATIONS**

AG107.1 General.

ANSI—American National Standards Institute
11 West 42nd Street
New York, NY 10036

APSP—Association of Pool and Spa Professionals
NSPI—National Spa and Pool Institute
2111 Eisenhower Avenue
Alexandria, VA 22314

ASCE—American Society of Civil Engineers
1801 Alexander Bell Drive
Reston, VA 98411-0700

ASTM—ASTM International
100 Barr Harbor Drive,
West Conshohocken, PA 19428

**SECTION AG108
STANDARDS**

AG108.1 General.

ANSI/NSPI

ANSI/NSPI-3-99 Standard for Permanently Installed Residential Spas AG104.1

ANSI/NSPI-4-99 Standard for Above-ground/ On-ground Residential Swimming Pools AG103.2

ANSI/NSPI-5-2003 Standard for Residential In-ground Swimming Pools. AG103.1

ANSI/NSPI-6-99 Standard for Residential Portable Spas AG104.2

ANSI/APSP

ANSI/APSP-7-06 Standard for Suction Entrapment avoidance in Swimming Pools, Wading Pools, Spas, Hot Tub and Catch Basins. AG106.1

ASTM

ASTM F 1346-91 (2003) Performance Specification for Safety Covers and Labeling Requirements for All Covers for Swimming Pools, Spas and Hot Tub AG105.2, AG105.5

APPENDIX H

PATIO COVERS

SECTION AH101 GENERAL

AH101.1 Scope. Patio covers more than 200 square feet (18.50 m²) shall conform to the requirements of this appendix chapter.

SECTION AH102 DEFINITION

Patio covers. One-story structures not exceeding 12 feet (3657 mm) in height. Enclosure walls shall be permitted to be of any configuration, provided the open or glazed area of the longer wall and one additional wall is equal to at least 65 percent of the area below a minimum of 6 feet 8 inches (2032 mm) of each wall, measured from the floor. Openings shall be permitted to be enclosed with (1) insect screening, (2) *approved* translucent or transparent plastic not more than 0.125 inch (3.2 mm) in thickness, (3) glass conforming to the provisions of Section R308, or (4) any combination of the foregoing.

SECTION AH103 PERMITTED USES

AH103.1 General. Patio covers shall be permitted to be detached from or attached to *dwelling units*. Patio covers shall be used only for recreational, outdoor living purposes and not as carports, garages, storage rooms or habitable rooms.

SECTION AH104 DESIGN LOADS

AH104.1 General. Patio covers shall be designed and constructed to sustain, within the stress limits of this code, all dead loads plus a minimum vertical live load of 10 pounds per square foot (0.48 kN/m²) except that snow loads shall be used where such snow loads exceed this minimum. Such covers shall be designed to resist the minimum wind loads set forth in Section R301.2.1.

SECTION AH105 LIGHT AND VENTILATION/EMERGENCY EGRESS

AH105.1 General. Exterior openings required for light and ventilation shall be permitted to open into a patio structure conforming to Section AH101, provided that the patio structure shall be unenclosed if such openings are serving as emergency egress or rescue openings from sleeping rooms. Where such exterior openings serve as an exit from the *dwelling unit*, the patio structure, unless unenclosed, shall be provided with exits conforming to the provisions of Section R310 of this code.

SECTION AH106 FOOTINGS

AH106.1 General. In areas with a frostline depth of zero as specified in Table R301.2(1), a patio cover shall be permitted to be supported on a slab on *grade* without footings, provided the slab conforms to the provisions of Section R506 of this code, is not less than 3.5 inches (89 mm) thick and the columns do not support live and dead loads in excess of 750 pounds (3.34 kN) per column.

APPENDIX I
PRIVATE SEWAGE DISPOSAL
(Not Adopted by the State of Oregon)

||

(The provisions contained in this appendix are not mandatory unless specifically referenced in the adopting ordinance.)

SECTION AI101
GENERAL

AI101.1 Scope. Private sewage disposal systems shall conform to the *International Private Sewage Disposal Code*.

APPENDIX J

EXISTING BUILDINGS AND STRUCTURES

(Not Adopted by the State of Oregon)

(The provisions contained in this appendix are not mandatory unless specifically referenced in the adopting ordinance.)

SECTION AJ101 PURPOSE AND INTENT

AJ101.1 General. The purpose of these provisions is to encourage the continued use or reuse of legally existing buildings and structures. These provisions are intended to permit work in existing buildings that is consistent with the purpose of the *International Residential Code*. Compliance with these provisions shall be deemed to meet the requirements of the *International Residential Code*.

AJ101.2 Classification of work. For purposes of this appendix, all work in existing buildings shall be classified into the categories of repair, renovation, *alteration* and reconstruction. Specific requirements are established for each category of work in these provisions.

AJ101.3 Multiple categories of work. Work of more than one category may be part of a single work project. All related work permitted within a 12-month period shall be considered a single work project. Where a project includes one category of work in one building area and another category of work in a separate and unrelated area of the building, each project area shall comply with the requirements of the respective category of work. Where a project with more than one category of work is performed in the same area or in related areas of the building, the project shall comply with the requirements of the more stringent category of work.

SECTION AJ102 COMPLIANCE

AJ102.1 General. Regardless of the category of work being performed, the work shall not cause the structure to become unsafe or adversely affect the performance of the building; shall not cause an existing mechanical or plumbing system to become unsafe, hazardous, insanitary or overloaded; and unless expressly permitted by these provisions, shall not make the building any less conforming to this code or to any previously *approved* alternative arrangements than it was before the work was undertaken.

AJ102.2 Requirements by category of work. Repairs shall conform to the requirements of Section AJ301. Renovations shall conform to the requirements of Section AJ401. *Alterations* shall conform to the requirements of Section AJ501 and the requirements for renovations. Reconstructions shall conform to the requirements of Section AJ601 and the requirements for *alterations* and renovations.

AJ102.3 Smoke detectors. Regardless of the category of work, smoke detectors shall be provided where required by Section R314.3.1.

AJ102.4 Replacement windows. Regardless of the category of work, when an existing window, including sash and glazed portion is replaced, the replacement window shall comply with the requirements of Chapter 11.

AJ102.5 Flood hazard areas. Work performed in existing buildings located in a flood hazard area as established by Table R301.2(1) shall be subject to the provisions of Section R105.3.1.1.

AJ102.6 Equivalent alternatives. These provisions are not intended to prevent the use of any alternate material, alternate design or alternate method of construction not specifically prescribed herein, provided any alternate has been deemed to be equivalent and its use authorized by the *building official*.

AJ102.7 Other alternatives. Where compliance with these provisions or with this code as required by these provisions is technically infeasible or would impose disproportionate costs because of structural, construction or dimensional difficulties, other alternatives may be accepted by the *building official*. These alternatives may include materials, design features and/or operational features.

AJ102.8 More restrictive requirements. Buildings or systems in compliance with the requirements of this code for new construction shall not be required to comply with any more restrictive requirement of these provisions.

AJ102.9 Features exceeding *International Residential Code* requirements. Elements, components and systems of existing buildings with features that exceed the requirements of this code for new construction, and are not otherwise required as part of *approved* alternative arrangements or deemed by the *building official* to be required to balance other building elements not complying with this code for new construction, shall not be prevented by these provisions from being modified as long as they remain in compliance with the applicable requirements for new construction.

SECTION AJ103 PRELIMINARY MEETING

AJ103.1 General. If a building *permit* is required at the request of the prospective *permit* applicant, the *building official* or his designee shall meet with the prospective applicant to discuss plans for any proposed work under these provisions prior to the application for the *permit*. The purpose of this preliminary meeting is for the *building official* to gain an understanding of the prospective applicant's intentions for the proposed work, and to determine, together with the prospective applicant, the specific applicability of these provisions.

SECTION AJ104 EVALUATION OF AN EXISTING BUILDING

AJ104.1 General. The *building official* may require an existing building to be investigated and evaluated by a registered design professional in the case of proposed reconstruction of any portion of a building. The evaluation shall determine the existence of any potential nonconformities with these provisions, and shall provide a basis for determining the impact of the proposed changes on the performance of the building. The evaluation shall use the following sources of information, as applicable:

1. Available documentation of the existing building.
 - 1.1. Field surveys.
 - 1.2. Tests (nondestructive and destructive).
 - 1.3. Laboratory analysis.

Exception: Detached one- or two-family dwellings that are not irregular buildings under Section R301.2.2.2.5 and are not undergoing an extensive reconstruction shall not be required to be evaluated.

SECTION AJ105 PERMIT

AJ105.1 Identification of work area. The work area shall be clearly identified on all *permits* issued under these provisions.

SECTION AJ201 DEFINITIONS

AJ201.1 General. For purposes of this appendix, the terms used are defined as follows.

ALTERATION. The reconfiguration of any space, the *addition* or elimination of any door or window, the reconfiguration or extension of any system, or the installation of any additional *equipment*.

CATEGORIES OF WORK. The nature and extent of construction work undertaken in an existing building. The categories of work covered in this Appendix, listed in increasing order of stringency of requirements, are repair, renovation, *alteration* and reconstruction.

DANGEROUS. Where the stresses in any member; the condition of the building, or any of its components or elements or attachments; or other condition that results in an overload exceeding 150 percent of the stress allowed for the member or material in this code.

EQUIPMENT OR FIXTURE. Any plumbing, heating, electrical, ventilating, air conditioning, refrigerating and fire protection *equipment*, and elevators, dumb waiters, boilers, pressure vessels, and other mechanical facilities or installations that are related to building services.

LOAD-BEARING ELEMENT. Any column, girder, beam, joist, truss, rafter, wall, floor or roof sheathing that supports any vertical load in addition to its own weight, and/or any lateral load.

MATERIALS AND METHODS REQUIREMENTS. Those requirements in this code that specify material standards; details of installation and connection; joints; penetrations; and continuity of any element, component or system in the building. The required quantity, fire resistance, flame spread, acoustic or thermal performance, or other performance attribute is specifically excluded from materials and methods requirements.

RECONSTRUCTION. The reconfiguration of a space that affects an exit, a renovation and/or *alteration* when the work area is not permitted to be occupied because existing means of egress and fire protection systems, or their equivalent, are not in place or continuously maintained; and/or there are extensive *alterations* as defined in Section AJ501.3.

REHABILITATION. Any repair, renovation, *alteration* or reconstruction work undertaken in an existing building.

RENOVATION. The change, strengthening or *addition* of load-bearing elements; and/or the refinishing, replacement, bracing, strengthening, upgrading or extensive repair of existing materials, elements, components, *equipment* and/or fixtures. Renovation involves no reconfiguration of spaces. Interior and exterior painting are not considered refinishing for purposes of this definition, and are not renovation.

REPAIR. The patching, restoration and/or minor replacement of materials, elements, components, *equipment* and/or fixtures for the purposes of maintaining those materials, elements, components, *equipment* and/or fixtures in good or sound condition.

WORK AREA. That portion of a building affected by any renovation, *alteration* or reconstruction work as initially intended by the owner and indicated as such in the *permit*. Work area excludes other portions of the building where incidental work entailed by the intended work must be performed, and portions of the building where work not initially intended by the owner is specifically required by these provisions for a renovation, *alteration* or reconstruction.

SECTION AJ301 REPAIRS

AJ301.1 Materials. Except as otherwise required herein, work shall be done using like materials or materials permitted by this code for new construction.

AJ301.1.1 Hazardous materials. Hazardous materials no longer permitted, such as asbestos and lead-based paint, shall not be used.

AJ301.1.2 Plumbing materials and supplies. The following plumbing materials and supplies shall not be used:

1. All-purpose solvent cement, unless listed for the specific application;
2. Flexible traps and tailpieces, unless listed for the specific application; and
3. Solder having more than 0.2 percent lead in the repair of potable water systems.

AJ301.2 Water closets. When any water closet is replaced with a newly manufactured water closet, the replacement water closet shall comply with the requirements of Section P2903.2.

AJ301.3 Safety glazing. Replacement glazing in hazardous locations shall comply with the safety glazing requirements of Section R308.1.

AJ301.4 Electrical. Repair or replacement of existing electrical wiring and *equipment* undergoing repair with like material shall be permitted.

Exceptions:

1. Replacement of electrical receptacles shall comply with the requirements of Chapters 34 through 43.
2. Plug fuses of the Edison-base type shall be used for replacements only where there is no evidence of overfusing or tampering per the applicable requirements of Chapters 34 through 43.
3. For replacement of nongrounding-type receptacles with grounding-type receptacles and for branch circuits that do not have an *equipment* grounding conductor in the branch circuitry, the grounding conductor of a grounding type receptacle outlet shall be permitted to be grounded to any accessible point on the grounding electrode system, or to any accessible point on the grounding electrode conductor, as allowed and described in Chapters 34 through 43.

SECTION AJ401 RENOVATIONS

AJ401.1 Materials and methods. The work shall comply with the materials and methods requirements of this code.

AJ401.2 Door and window dimensions. Minor reductions in the clear opening dimensions of replacement doors and windows that result from the use of different materials shall be allowed, whether or not they are permitted by this code.

AJ401.3 Interior finish. Wood paneling and textile wall coverings used as an interior finish shall comply with the flame spread requirements of Section R302.9.

AJ401.4 Structural. Unreinforced masonry buildings located in Seismic Design Category D₂ or E shall have parapet bracing and wall anchors installed at the roofline whenever a reroofing *permit* is issued. Such parapet bracing and wall anchors shall be of an *approved* design.

SECTION AJ501 ALTERATIONS

AJ501.1 Newly constructed elements. Newly constructed elements, components and systems shall comply with the requirements of this code.

Exceptions:

1. Openable windows may be added without requiring compliance with the light and ventilation requirements of Section R303.
2. Newly installed electrical *equipment* shall comply with the requirements of Section AJ501.5.

AJ501.2 Nonconformities. The work shall not increase the extent of noncompliance with the requirements of Section

AJ601, or create nonconformity with those requirements which did not previously exist.

AJ501.3 Extensive alterations. When the total area of all the work areas included in an *alteration* exceeds 50 percent of the area of the *dwelling unit*, the work shall be considered as a reconstruction and shall comply with the requirements of these provisions for reconstruction work.

Exception: Work areas in which the *alteration* work is exclusively plumbing, mechanical or electrical shall not be included in the computation of total area of all work areas.

AJ501.4 Structural. The minimum design loads for the structure shall be the loads applicable at the time the building was constructed, provided that no dangerous condition is created. Structural elements that are uncovered during the course of the *alteration* and that are found to be unsound or dangerous shall be made to comply with the applicable requirements of this code.

AJ501.5 Electrical equipment and wiring.

AJ501.5.1 Materials and methods. Newly installed electrical *equipment* and wiring relating to work done in any work area shall comply with the materials and methods requirements of Chapters 34 through 43.

Exception: Electrical *equipment* and wiring in newly installed partitions and ceilings shall comply with all applicable requirements of Chapters 34 through 43.

AJ501.5.2 Electrical service. Service to the *dwelling unit* shall be a minimum of 100 ampere, three-wire capacity and service *equipment* shall be dead front having no live parts exposed that could allow accidental contact. Type “S” fuses shall be installed when fused *equipment* is used.

Exception: Existing service of 60 ampere, three-wire capacity, and feeders of 30 ampere or larger two- or three-wire capacity shall be accepted if adequate for the electrical load being served.

AJ501.5.3 Additional electrical requirements. When the work area includes any of the following areas within a *dwelling unit*, the requirements of Sections AJ501.5.3.1 through AJ501.5.3.5 shall apply.

AJ501.5.3.1 Enclosed areas. Enclosed areas other than closets, kitchens, *basements*, garages, hallways, laundry areas and bathrooms shall have a minimum of two duplex receptacle outlets, or one duplex receptacle outlet and one ceiling or wall type lighting outlet.

AJ501.5.3.2 Kitchen and laundry areas. Kitchen areas shall have a minimum of two duplex receptacle outlets. Laundry areas shall have a minimum of one duplex receptacle outlet located near the laundry *equipment* and installed on an independent circuit.

AJ501.5.3.3 Ground-fault circuit-interruption. Ground fault circuit interruption shall be provided on newly installed receptacle outlets if required by Chapters 34 through 43.

AJ501.5.3.4 Lighting outlets. At least one lighting outlet shall be provided in every bathroom, hallway, stairway, attached garage and detached garage with electric

power to illuminate outdoor entrances and exits, and in utility rooms and *basements* where these spaces are used for storage or contain *equipment* requiring service.

AJ501.5.3.5 Clearance. Clearance for electrical service *equipment* shall be provided in accordance with Chapters 34 through 43.

AJ501.6 Ventilation. All reconfigured spaces intended for occupancy and all spaces converted to habitable or occupiable space in any work area shall be provided with ventilation in accordance with Section R303.

AJ501.7 Ceiling height. *Habitable spaces* created in existing *basements* shall have ceiling heights of not less than 6 feet 8 inches (2032 mm). Obstructions may project to within 6 feet 4 inches (1930 mm) of the *basement* floor. Existing finished ceiling heights in nonhabitable spaces in *basements* shall not be reduced.

AJ501.8 Stairs.

AJ501.8.1 Stair width. Existing *basement* stairs and handrails not otherwise being altered or modified shall be permitted to maintain their current clear width at, above, and below existing handrails.

AJ501.8.2 Stair headroom. Headroom height on existing *basement* stairs being altered or modified shall not be reduced below the existing stairway finished headroom. Existing *basement* stairs not otherwise being altered shall be permitted to maintain the current finished headroom.

AJ501.8.3 Stair landing. Landings serving existing *basement* stairs being altered or modified shall not be reduced below the existing stairway landing depth and width. Existing *basement* stairs not otherwise being altered shall be permitted to maintain the current landing depth and width.

SECTION AJ601 RECONSTRUCTION

AJ601.1 Stairways, handrails and guards.

AJ601.1.1 Stairways. Stairways within the work area shall be provided with illumination in accordance with Section R303.6.

AJ601.1.2 Handrails. Every required exit stairway that has four or more risers, is part of the means of egress for any work area, and is not provided with at least one handrail, or in which the existing handrails are judged to be in danger of collapsing, shall be provided with handrails designed and installed in accordance with Section R311 for the full length of the run of steps on at least one side.

AJ601.1.3 Guards. Every open portion of a stair, landing or balcony that is more than 30 inches (762 mm) above the floor or *grade* below, is part of the egress path for any work area, and does not have guards or in which the existing guards are judged to be in danger of collapsing, shall be provided with guards designed and installed in accordance with Section R312.

AJ601.2 Wall and ceiling finish. The interior finish of walls and ceilings in any work area shall comply with the requirements of Section R302.9. Existing interior finish materials that

do not comply with those requirements shall be removed or shall be treated with an *approved* fire-retardant coating in accordance with the manufacturer's instructions to secure compliance with the requirements of this section.

AJ601.3 Separation walls. Where the work area is in an attached *dwelling unit*, walls separating *dwelling units* that are not continuous from the foundation to the underside of the roof sheathing shall be constructed to provide a continuous fire separation using construction materials consistent with the existing wall or complying with the requirements for new structures. Performance of work shall be required only on the side of the wall of the *dwelling unit* that is part of the work area.

AJ601.4 Ceiling height. *Habitable spaces* created in existing *basements* shall be permitted to have ceiling heights of not less than 6 feet 8 inches (2032 mm). Obstructions may project to within 6 feet 4 inches (1930 mm) of the *basement* floor. Existing finished ceiling heights in nonhabitable spaces in *basements* shall not be reduced.

APPENDIX K
SOUND TRANSMISSION

SECTION AK101
GENERAL

AK101.1 General. Wall and floor-ceiling assemblies separating dwelling units shall provide airborne sound insulation for walls, and both airborne and impact sound insulation for floor-ceiling assemblies.

SECTION AK102
AIRBORNE SOUND

AK102.1 General. Airborne sound insulation for wall and floor-ceiling assemblies shall meet a Sound Transmission Class (STC) rating of 45 when tested in accordance with ASTM E 90.

SECTION AK103
STRUCTURAL-BORNE SOUND

AK103.1 General. Floor-ceiling assemblies between dwelling units or between a dwelling unit and a public or service area within a structure shall have an Impact Insulation Class (IIC) rating of not less than 45 when tested in accordance with ASTM E 492.

SECTION AK104
REFERENCED STANDARDS

ASTM E 90-99 Test Method for Laboratory Measurement of Airborne Sound Transmission Loss of Building Partitions and Elements	AK102
ASTM E 492-90 (1996)e Specification for Laboratory Measurement of Impact Sound Transmission through Floor-ceiling Assemblies Using the Tapping Machine	AK103