

## APPENDIX D

# FIRE APPARATUS ACCESS ROADS

*The provisions contained in this appendix are adopted by the State of Oregon.*

### SECTION D101 GENERAL

**D101.1 Scope.** Fire apparatus access roads shall be in accordance with this appendix and all other applicable requirements of the *International Fire Code*. The *fire code official* may be guided by the Oregon Department of Land and Conservation and Development's Neighborhood Street Design Guidelines, June 2001.

### SECTION D102 REQUIRED ACCESS

**D102.1 Access and loading.** Facilities, buildings or portions of buildings hereafter constructed shall be accessible to fire department apparatus by way of an *approved* fire apparatus access road with an asphalt, concrete or other *approved* driving surface capable of supporting the imposed load of fire apparatus weighing at least 60,000 pounds (27 240 kg).

**Exception:** The minimum weight specified in Section D102.1 may be increased by the *fire code official* based upon the actual weight of fire apparatus vehicles serving the jurisdiction that provides structural fire protection services to the location, including fire apparatus vehicles that respond under automatic and mutual aid agreements.

**D102.1.1 Access in wildland-urban interface areas.** For egress and access concerns in wildland-urban interface locations, the *fire code official* may be guided by the *International Wildland-Urban Interface Code*.

### SECTION D103 MINIMUM SPECIFICATIONS

**D103.1 Access road width with a hydrant.** Where a fire hydrant is located on a fire apparatus access road, the minimum road width shall be 26 feet (7925 mm), exclusive of shoulders (see Figure D103.1).

**Exception:** The *fire code official* is authorized to modify the provisions of Section D103.1 when:

1. In accordance with Oregon Administrative Rule (OAR) 918-480-0100, all buildings are completely protected with an approved automatic fire sprinkler system;
2. Provisions are made for the emergency use of sidewalks by such means as rolled or mountable curbs capable of supporting the fire department's apparatus;
3. Streets or roadways are identified for one-way circulating flow of traffic or pullouts are provided every 150 feet (45 720 mm) on streets or roadways identified for two-way traffic; or
4. A grid system for traffic flow is provided and streets or roadways in the grid do not exceed 300 feet (91 400 mm) in length but are accessible at each end from approved access roadways or streets.

**D103.2 Grade.** Fire apparatus access roads shall not exceed 10 percent in grade.

**Exception:** Grades steeper than 10 percent as *approved* by the fire chief.

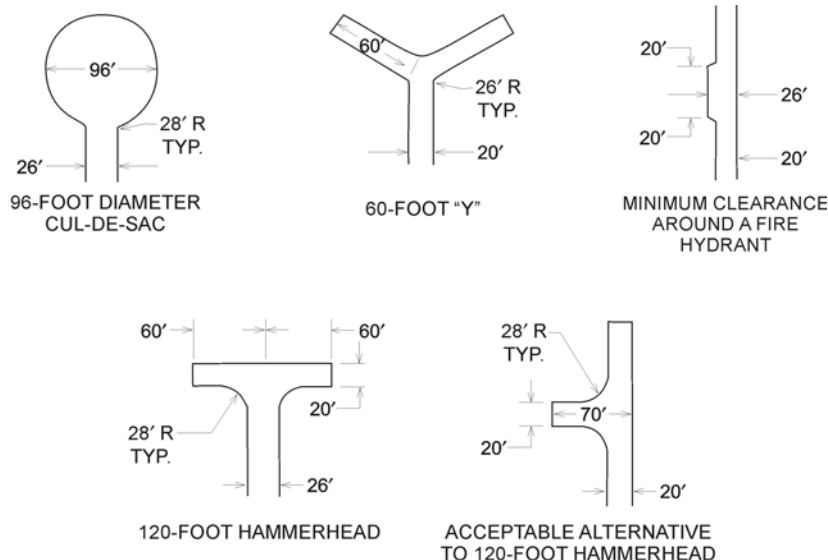

For SI: 1 foot = 304.8 mm.

**FIGURE D103.1**  
**DEAD-END FIRE APPARATUS ACCESS ROAD TURNAROUND**

**D103.3 Turning radius.** The minimum turning radius shall be determined by the *fire code official*.

**D103.3.1 Drainage.** When subject to run-off damage, the *fire code official* is authorized to require approved drainage.

**D103.4 Dead ends.** Dead-end fire apparatus access roads in excess of 150 feet (45 720 mm) shall be provided with width and turnaround provisions in accordance with Table D103.4.

**TABLE D103.4  
REQUIREMENTS FOR DEAD-END  
FIRE APPARATUS ACCESS ROADS**

LENGTH (feet)	WIDTH (feet)	TURNAROUNDS REQUIRED
0-150	20	None required
151-500	20	120-foot Hammerhead, 60-foot “Y” or 96-foot diameter cul-de-sac in accordance with Figure D103.1
501-750	26	120-foot Hammerhead, 60-foot “Y” or 96-foot diameter cul-de-sac in accordance with Figure D103.1
Over 750		Special approval required

For SI: 1 foot = 304.8 mm.

**D103.5 Fire apparatus access road gates.** Gates securing the fire apparatus access roads shall comply with all of the following criteria:

1. The minimum gate width shall be 20 feet (6096 mm).
2. Gates shall be of the swinging or sliding type.
3. Construction of gates shall be of materials that allow manual operation by one person.
4. Gate components shall be maintained in an operative condition at all times and replaced or repaired when defective.
5. Electric gates shall be equipped with a means of opening the gate by fire department personnel for emergency access. Emergency opening devices shall be *approved* by the *fire code official*.
6. Manual opening gates shall not be locked with a padlock or chain and padlock unless they are capable of being opened by means of forcible entry tools or when a key box containing the key(s) to the lock is installed at the gate location.
7. Locking device specifications shall be submitted for approval by the *fire code official*.
8. Electric gate operators, where provided, shall be *listed* in accordance with UL 325.
9. Gates intended for automatic operation shall be designed, constructed and installed to comply with the requirements of ASTM F 2200.

**D103.6 Signs.** Where required by the *fire code official*, fire apparatus access roads shall be marked with permanent NO PARKING—FIRE LANE signs complying with Figure D103.6. Signs shall have a minimum dimension of 12 inches (305 mm) wide by 18 inches (457 mm) high and have red letters on a white reflective background. Signs shall be posted

on one or both sides of the fire apparatus road as required by Section D103.6.1 or D103.6.2.

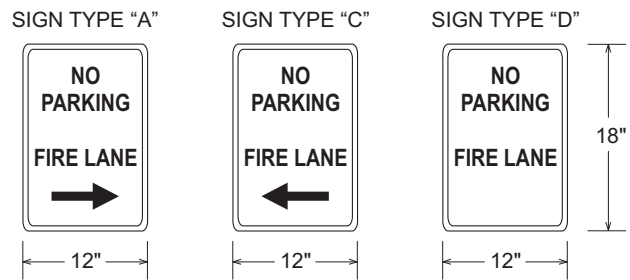

**FIGURE D103.6  
FIRE LANE SIGNS**

**D103.6.1 Roads 20 to 26 feet in width.** Fire lane signs as specified in Section D103.6 shall be posted on both sides of fire apparatus access roads that are 20 to 26 feet wide (6096 to 7925 mm).

**D103.6.2 Roads more than 26 feet in width.** Fire lane signs as specified in Section D103.6 shall be posted on one side of fire apparatus access roads more than 26 feet wide (7925 mm) and less than 32 feet wide (9754 mm).

**SECTION D104  
COMMERCIAL AND INDUSTRIAL DEVELOPMENTS**

**D104.1 Buildings exceeding three stories or 30 feet in height.** Buildings or facilities exceeding 30 feet (9144 mm) or three stories in height shall have at least two means of fire apparatus access for each structure.

**D104.2 Buildings exceeding 62,000 square feet in area.** Buildings or facilities having a gross *building area* of more than 62,000 square feet (5760 m<sup>2</sup>) shall be provided with two separate and *approved* fire apparatus access roads.

**Exception:** Projects having a gross *building area* of up to 124,000 square feet (11 520 m<sup>2</sup>) that have a single *approved* fire apparatus access road when all buildings are equipped throughout with *approved automatic sprinkler systems*.

**D104.3 Remoteness.** Where two fire apparatus access roads are required, they shall be placed a distance apart equal to not less than one half of the length of the maximum overall diagonal dimension of the lot or area to be served, measured in a straight line between accesses.

**SECTION D105  
AERIAL FIRE APPARATUS ACCESS ROADS**

**D105.1 Where required.** Where the vertical distance between the grade plane and the highest roof surface exceeds 30 feet (9144 mm), approved aerial fire apparatus access roads shall be provided. For purposes of this section, the highest roof surface shall be determined by measurement to the eave of a pitched roof, the intersection of the roof to the exterior wall, or the top of parapet walls, whichever is greater.

**D105.2 Width.** Aerial fire apparatus access roads shall have a minimum unobstructed width of 26 feet (7925 mm), exclusive of shoulders, in the immediate vicinity of the building or portion thereof.

**D105.3 Proximity to building.** At least one of the required access routes meeting this condition shall be located within a minimum of 15 feet (4572 mm) and a maximum of 30 feet (9144 mm) from the building, and shall be positioned parallel to one entire side of the building. The side of the building on which the aerial fire apparatus access road is positioned shall be approved by the *fire code official*.

**D105.4 Obstructions.** Overhead utility and power lines shall not be located over the aerial fire apparatus access road or between the aerial fire apparatus road and the building. Other obstructions shall be permitted to be placed with the approval of the *fire code official*.

2. The number of *dwelling units* on a single fire apparatus access road shall not be increased unless fire apparatus access roads will connect with future development, as determined by the *fire code official*.

**D108  
REFERENCED STANDARDS**

ASTM	F 2200—05	Standard Specification for Automated Vehicular Gate Construction	D103.5
ICC	IFC—12	International Fire Code	D101.5, D107.1
UL	325—02	Door, Drapery, Gate, Louver, and Window Operators and Systems, with Revisions through February 2006	D103.5

**SECTION D106**

**MULTIPLE-FAMILY RESIDENTIAL DEVELOPMENTS**

**D106.1 Projects having more than 100 dwelling units.** Multiple-family residential projects having more than 100 *dwelling units* shall be equipped throughout with two separate and *approved* fire apparatus access roads.

**Exception:** Projects having up to 200 *dwelling units* may have a single *approved* fire apparatus access road when all buildings, including nonresidential occupancies, are equipped throughout with *approved automatic sprinkler systems* installed in accordance with Section 903.3.1.1 or 903.3.1.2.

**D106.2 Projects having more than 200 dwelling units.** Multiple-family residential projects having more than 200 *dwelling units* shall be provided with two separate and *approved* fire apparatus access roads regardless of whether they are equipped with an *approved automatic sprinkler system*.

**SECTION D107**

**ONE- OR TWO-FAMILY  
RESIDENTIAL DEVELOPMENTS**

**D107.1 One- or two-family dwelling residential developments.** Developments of one- or two-family *dwelling units* where the number of *dwelling units* exceeds 30 shall be provided with two separate and *approved* fire apparatus access roads, and shall meet the requirements of Section D104.3.

**Exceptions:**

1. Where there are more than 30 *dwelling units* on a single public or private fire apparatus access road and all *dwelling units* are equipped throughout with an *approved automatic sprinkler system* in accordance with Section 903.3.1.1, 903.3.1.2 or 903.3.1.3 of the *International Fire Code*, access from two directions shall not be required.

